

# COUNCIL MEETING AGENDA

Casper City Council  
City Hall, Council Chambers  
Tuesday, February 2, 2021, 6:00 p.m.



## COUNCIL POLICY PUBLIC STATEMENTS

- I. Members of the Public Wishing to Speak to an Item Already on the Agenda, Other Than a Public Hearing, or Second or Third Reading Ordinance, Must Submit a Request to the City Clerk's Office by 12:00 Noon on the Monday Immediately Preceding the Council Meeting, or May Speak During the Communications From Persons Present.
- II. When Speaking to the City Council Please:
  - Clearly State Your Name and Address.
  - Direct all questions/comments to the Mayor and only the Mayor.
  - No personal attacks on staff or Council.
  - Speak to the City Council with Civility and Decorum.
- III. The City Council Will Not Respond to Any Comments or Questions Concerning Personnel Matters. Any Such Comments or Questions Will be Handled by the Appropriate Persons. Public Hearing Comments and Presentations Will be Limited to Five Minutes or Less per Person, nor Will Time Extensions be Permitted. No Duplication of Speakers will be Allowed.
- IV. Questions Posed by Speakers May, or May Not be Responded to by Council Members.
- V. Willful Disruption of, or the Breach of the Peace at, a Council Meeting may Result in the Removal of any Such Individuals or Groups from the Council Chambers.  
(These Guidelines Are Also Posted at the Podium in the Council Chambers)

*\*Please silence cell phones during the City Council meeting.\**

**COVID-19 precautions are in effect at Council meetings. All Council meetings including Work Sessions are held in Chambers. Entrance to the meetings is the east door off David Street. Upon entry you will be asked to sign-in for contact tracing purposes. Face coverings are encouraged. Seating has been gridded into six feet distances. Seating capacity for the public is fifteen seats. Media will be given priority for seating. Public input via email is encouraged: [CouncilComments@casperwy.gov](mailto:CouncilComments@casperwy.gov). Citizens may call 307-235-7568 from 8 a.m. to 5 p.m. Monday or 8 a.m. to noon on Tuesday of the meeting to schedule a call for the Council meeting. Staff will provide citizens with a link or phone number to call in to speak during the meeting along with instructions.**

We are CASPER

Communication Accountability Stewardship Professionalism Efficiency Responsiveness

AGENDA

1. ROLL CALL
  2. PLEDGE OF ALLEGIANCE
  3. CONSIDERATION OF MINUTES OF THE JANUARY 19, 2021 REGULAR COUNCIL MEETING, AS PUBLISHED IN THE CASPER STAR-TRIBUNE ON JANUARY 24, 2021
  4. CONSIDERATION OF MINUTES OF THE JANUARY 19, 2021 EXECUTIVE SESSION – PERSONNEL
  5. CONSIDERATION OF BILLS AND CLAIMS
  6. COMMUNICATIONS
    - A. From Persons Present
  7. ESTABLISH DATE OF PUBLIC HEARING
    - A. Consent
      1. Establish February 16, 2021, as the Public Hearing Date for Consideration of:
        - a. Vacation and Replat Creating the **Trails West Estates No. 4 Addition**, a Zone Change of Said Subdivision, and the Trails West Estates No. 4 Subdivision Agreement.
        - b. Creation of **Local Assessment District 158–Coates Road** Surfacing Improvements.
8. PUBLIC HEARINGS
  - A. Ordinance
    1. **Vacation** a Portion of **East 7<sup>th</sup> Street**.
    2. **Repealing Ordinance No. 54-00** as Codified by Article IV, Chapter 9.40 of the Casper Municipal Code Titled “Sale of Nicotine Products”.
  - B. Minute Action
    1. **New Restaurant Liquor License No. 43** for Ludovico, d/ba/ **Ludovico** Located at 1301 Wilkins Circle.
9. THIRD READING ORDINANCES
  - A. Amending **Chapter 9.24 of the Casper Municipal Code** – Offenses Against Public Decency, Modifying Certain Sections and Creating New Sections Thereof. (**Prostitution**)
    1. Communications from Persons Present

We are CASPER

Communication   Accountability   Stewardship   Professionalism   Efficiency   Responsiveness

9. THIRD READING ORDINANCES (continued)

B. **Amending Section 10.24.010** of the Casper Municipal Code (**Speed Zones**).

1. Communications from Persons Present

10. SECOND READING ORDINANCES

A. Plat of **Highland Park Cemetery Addition No. 2**.

1. Communications from Persons Present

B. **Annexation and Plat** Creating the **East Robertson Road Addition** and **3489 South Robertson Road** to the City of Casper, and Zoning of said Addition and Address as AG (Urban Agriculture).

1. Communications from Persons Present

11. RESOLUTIONS

A. Authorizing an Agreement with **Crown Construction, LLC**, in the Amount of \$209,044.00 for the **Recycle Depot Improvements Project**.

B. Consent

1. Authorizing Acceptance of Funds Awarded from the **Drug Enforcement Administration**, in the Amount of \$35,000, to be Used for Overtime Reimbursement of Officers that are Directly Involved in the **Eradication and Suppression of Illicit Cannabis**.
2. Authorizing an Agreement with **Caspar Building Systems, Inc.**, in the Amount of \$86,626, for the **Baler Building Locker Room Remodel Project**.
3. Authorizing an Agreement with **Wayne Coleman Construction, Inc.**, in the Amount of \$90,307.00 for the **Horizon Park Project**.
4. Authorizing an Agreement with **Installation and Service Company, Inc.**, in the Amount of \$142,482.50 for the **2<sup>nd</sup> Street Mill and Overlay Project**.
5. **Rescinding** the City of Casper's Participation in the **Unified Command to Oversee the Management of the COVID-19 Pandemic** as Referenced in Natrona County's Resolution No. 11-20 and the City of Casper Resolution No. 20-72.
6. Authorizing the Acceptance of a **Donation of Used Equipment** and Enter into a Release, Acknowledgement and Waiver with the **Sinclair Casper Refining Company**.

We are CASPER

Communication Accountability Stewardship Professionalism Efficiency Responsiveness

12. MINUTE ACTION

A. Consent

1. Acknowledging the **Receipt of Financial Disclosure Information** from City Officials with **Public Fund Investment Responsibility**.
2. Reappointing **Mr. Bruce English** to the **Casper Public Utilities Advisory Board** for a Six-Year Term Ending December 31, 2026.

13. INTRODUCTION OF MEASURES AND PROPOSALS BY MEMBERS OF THE CITY COUNCIL

14. ADJOURN INTO EXECUTIVE SESSION – LAND ACQUISITION, PERSONNEL AND LITIGATION

15. ADJOURNMENT

Upcoming Council meetings

**Council meetings**

6:00 p.m. Tuesday, February 16, 2021– Council Chambers

6:00 p.m. Tuesday, March 2, 2021 – Council Chambers

**Work sessions**

4:30 p.m. Tuesday, February 9, 2021 – Council Chambers

4:30 p.m. Tuesday, February 3, 2021– Council Chambers

---

ZONING CLASSIFICATIONS

FC	Major Flood Channels & Riverbanks	PUD	Planned Unit Development
AG	Urban Agriculture	HM	Hospital Medical
R-1	Residential Estate	C-1	Neighborhood Convenience
R-2	One Unit Residential	C-2	General Business
R-3	One to Four Unit Residential	C-3	Central Business
R-4	High-Density Residential	C-4	Highway Business
R-5	Mixed Residential	M-1	Limited Industrial
R-6	Manufactured Home (Mobile) Park	M-2	General Industrial
PH	Park Historic	SMO	Soil Management Overlay
HO	Historic Overlay	ED	Education
OB	Office Business	OYD	Old Yellowstone District

---

We are CASPER

Communication   Accountability   Stewardship   Professionalism   Efficiency   Responsiveness



COUNCIL PROCEEDINGS  
Casper City Hall – Council Chambers  
January 19, 2021

1. ROLL CALL

Casper City Council met in regular session at 6:21 p.m., Tuesday, January 19, 2021. Present: Councilmembers Cathey, Engebretsen, Gamroth, Knell, Pacheco, Pollock and Mayor Freel. Absent: Councilmembers Johnson and Lutz.

Moved by Vice Mayor Pacheco, seconded by Councilmember Pollock, to, by minute action, excuse the absence of Councilmembers Johnson and Lutz. Motion passed.

2. PLEDGE OF ALLEGIANCE

A member of the Casper Youth Council led the audience in the Pledge of Allegiance.

3. MINUTES

Moved by Councilmember Knell, seconded by Councilmember Engebretsen, to, by minute action, approve the minutes of the January 5, 2021, regular Council meeting, as published in the Casper-Star Tribune on January 13, 2021. Motion passed.

4. BILLS & CLAIMS

Moved by Councilmember Pollock, seconded by Vice Mayor Pacheco, to, by minute action, approve payment of the January 19, 2021, bills and claims, as audited by City Manager Napier. Motion passed.

Bills & Claims 01/19/21		
477 KM	Goods	159.00
AMBI	Services	1,024.98
AAALndspng	Services	145.00
AceHrdw	Goods	196.25
Adecco	Services	1,138.54
ADobson	Reimb	94.49
AffiliatesinCnslng	Services	600.00
AhernRntls	Goods	1,130.50
Airgas	Goods	3,080.56
AlSCO	Services	497.23
Amerigas	Goods	42,092.06
AtlasOffice	Goods	669.97
BnkofAmerica	Goods	112,936.34
Bar-DSgns	Goods	5,192.00
BigHrnTire	Goods	218.00
BlkmnProp	Goods	139.00
Bloedorn	Goods	45.68
BreckMedia	Services	500.00
CATC	Funding	146,682.38
CsprCllge	Services	454.00

CsprHsngAuth	Funding	30,681.42
CsprTire	Goods	409.00
CntrlWyRegWtr	Services	324,602.28
Charter	Services	71.07
CtyofCspr	Services	10.00
CitySvcElect	Services	14,239.55
CivilEng	Services	937.50
CMITeco	Goods	66,049.39
CommTech	Goods	103.00
Comtronix	Goods	980.18
CompProf	Goods	10,604.97
CPotter	Reimb	101.04
DeckerAuto	Goods	360.29
Dell	Goods	4,868.29
DiamondVogel	Goods	52.31
Diebold	Goods	649.85
EBecher	Reimb	68.00
EMoore	Reimb	133.19
EngDsgn	Services	2,312.50
Ferguson	Goods	185.07
FtCsparMsmAssoc	Goods	460.50
Galls	Goods	2,114.64
GGraff	Reimb	135.49
GilletteStl	Goods	16,615.00
Grainger	Goods	210.28
GrtrWyBgBroth	Funding	11,042.93
HDREng	Services	1,276.70
HitekComm	Services	1,059.00
HMRBttrs	Goods	135.00
Homax	Goods	19,568.64
HUBIntl	Services	869.00
ITCElect	Services	1,362.00
JacksTrck	Goods	258.20
JKCEng	Services	5,024.00
JKegler	Reimb	92.39
JshsStrhse	Funding	3,900.00
JWarne	Reimb	47.24
KiwanisClb	Dues	144.00
KncklDrgr	Goods	2,025.00
Kubwtr	Goods	5,618.85
MthrSetonHsng	Funding	7,202.90
Motorola	Goods	5,165.95
MtnStsLitho	Services	213.58
MncplCde	Goods	512.01
NatareCorp	Services	35,077.60

NCHCorp	Goods	525.00
NCHOJ	Services	10,382.03
NCOff	Services	63,775.34
NCSheriff	Services	7,500.00
NCTrsr	Services	100.00
Norco	Goods	2,259.93
NrthnLghts	Goods	2,905.00
NWCntrctrs	Services	1,348.41
OneCall	Services	531.00
PCNStrtgs	Services	29,489.45
Pedens	Goods	1,376.50
PriceClngg	Services	360.00
ProfClngg	Services	1,395.00
RRMgmt	Services	284.85
Ricoh	Services	294.31
RouterSwr	Services	315.88
SlfHlpCtr	Funding	11,027.75
SixRobbles	Goods	184.31
Smarsh	Services	1,842.00
SmthPsych	Services	800.00
SoftDr	Goods	59.05
StofWY-Offlnd	Loan	147,040.72
StofWY-DEQ	Services	1,400.00
StofWy-Dadmn	Services	11,305.54
Sterling	Goods	403.98
SummitElect	Services	244.71
SummitPrtnrs	Services	2,737.54
TDach	Reimb	250.00
Thatcher	Goods	9,674.11
TheARC	Funding	2,333.35
ThirtyThreeMlRd	Services	127.40
TopOffice	Goods	532.50
TriStateOil	Goods	364.50
Trihydro	Services	375.00
TylerTech	Goods	2,121.00
Uniforms2gr	Goods	446.30
VerizonNWF	Services	1,699.95
Verizon	Services	431.78
VolanceLng	Services	25.00
VRCCo	Services	131.58
WstWtr	Services	1,551.00
WtrTech	Services	6,315.43
WynColemanConst	Services	30.00
WearPrts	Goods	11.01
WestPlnsEng	Services	700.00

WesternRsrch	Services	8,755.10
WWCEng	Services	27,637.32
WhitesBfflSprt	Goods	1,114.13
WyMachinery	Goods	198.00
WyWtrDev	Services	9,750.00
WYWtrQlty	Services	30.00
WySteel	Services	7,750.20
YthCrsisCtr	Funding	13,962.00
Total		1,290,750.74

5. COMMUNICATIONS FROM PERSONS PRESENT

No citizens addressed the Council.

6. ESTABLISH PUBLIC HEARINGS

Moved by Councilmember Gamroth, seconded by Councilmember Engebretsen, to, by minute action: establish February 2, 2021, as the public hearing date for the consideration of the vacation a portion of East 7<sup>th</sup> Street; repealing Ordinance No. 54-00 as codified by Article IV, Chapter 9.40 of the Casper Municipal Code titled “Sale of Nicotine Products”; and new Restaurant Liquor License No. 43 for Ludovico, d/b/a/ Ludovico located at 1301 Wilkins Circle. Councilmember Pollock abstained on the liquor license item. Motion passed.

7.A.1 PUBLIC HEARING - ORDINANCE

Moved by Vice Mayor Pacheco, seconded by Councilmember Cathey, to, by minute action cancel the public hearing for repealing Ordinance No. 54-00 as codified by Article IV, Chapter 9.40 of the Casper Municipal Code. Motion passed.

7.A.2 PUBLIC HEARING - ORDINANCE

Mayor Freel opened the public hearing for the consideration of the plat of Highland Park Cemetery Addition No. 2.

City Attorney Henley entered two (2) exhibits: correspondence from Liz Becher to J. Carter Napier, dated December 21, 2021 and an affidavit of publication, as published in the Casper-Star Tribune, dated January 6, 2021. City Manager Napier provided a brief report.

There being no one to speak for or against the issues involving Highland Park Cemetery Addition No. 2, the public hearing was closed.

Following ordinance read:

ORDINANCE NO. 3-21  
AN ORDINANCE APPROVING THE PLAT OF THE  
HIGHLAND PARK CEMETERY ADDITION NO. 2.

Councilmember Cathey presented the foregoing ordinance for approval, on first reading. Seconded by Councilmember Engebretsen. Motion passed.

7.A.3 PUBLIC HEARING - ORDINANCE

Mayor Freel opened the public hearing for the consideration of the annexation and plat creating the East Robertson Road Addition and 3489 South Robertson Road.

City Attorney Henley entered two (2) exhibits: correspondence from Liz Becher to J. Carter Napier, dated January 6, 2021 and an affidavit of publication, as published in the Casper-Star Tribune, dated January 6, 2021. City Manager Napier provided a brief report.

There being no one to speak for or against the issues involving the East Robertson Road Addition and 3489 South Robertson Road, the public hearing was closed.

Following ordinance read:

ORDINANCE NO. 4-21

AN ORDINANCE APPROVING THE CITY-INITIATED ANNEXATION OF THE EAST ROBERTSON ROAD ADDITION; AND A COUNCIL-INITIATED REZONE OF THE PROPERTY LOCATED AT 3489 SOUTH ROBERTSON ROAD.

Vice Mayor Pacheco presented the foregoing ordinance for approval, on first reading. Seconded by Councilmember Gamroth.

Councilmembers Knell, Engebretsen, Gamroth and Pollock had questions about the annexation process and the particulars of this location. City Manager Napier addressed these concerns. Mayor Freel and Councilmember Engebretsen abstained. Motion passed.

8.A ORDINANCE— SECOND READING

Following ordinance read:

ORDINANCE NO. 1-21

AN ORDINANCE AMENDING CHAPTER 9.24 OF THE CASPER MUNICIPAL CODE – OFFENSES AGAINST PUBLIC DECENCY, MODIFYING CERTAIN SECTIONS AND CREATING NEW SECTIONS THEREOF.

Councilmember Cathey presented the foregoing ordinance for approval, on second reading. Seconded by Vice Mayor Pacheco.

No citizens addressed Council.

Moved by Vice Mayor Pacheco to amend Section 9.24.050, Subsection A., deleting reference to Wyoming Statute Section 6-4-104 on line three, and replacing it with Wyoming State Statute Section 6-4-101, to correct the typographical error. Seconded by Councilmember Cathey. Motion to amend passed. Council then voted on the ordinance, as amended, on second reading. Motion passed.

8.B ORDINANCE— SECOND READING

Following ordinance read:

ORDINANCE NO. 2-21  
AN ORDINANCE AMENDING SECTION 10.24.010 OF THE  
CASPER MUNICIPAL CODE PERTAINING TO TWENTY MILE  
PER HOUR SPEED ZONES

Councilmember Cathey presented the foregoing ordinance for approval, on second reading. Seconded by Councilmember Pollock.

There being no one to speak regarding the ordinance, and no discussion or amendments, motion passed.

9. CONSENT RESOLUTIONS

The following resolutions were considered, by consent agenda:

RESOLUTION NO. 21-6  
A RESOLUTION AUTHORIZING AMENDMENT NO. 1 TO  
THE CONTRACT FOR PROFESSIONAL SERVICES WITH  
JACOBS ENGINEERING GROUP, INC., FOR ENGINEERING  
SERVICES FOR THE NORTH PLATTE SANITARY SEWER  
REHABILITATION, PROJECT NO. 20-015.

RESOLUTION NO. 21-7  
A RESOLUTION AUTHORIZING A CONTRACT FOR  
PROFESSIONAL SERVICES WITH ALLIANCE  
COMMUNICATION AND TECHNOLOGIES FOR DESIGN  
AND DESIGN CONSTRUCTION SERVICES FOR THE  
DOWNTOWN PARKING STRUCTURE SECURITY  
CAMERAS, PROJECT NO. 20-023.

RESOLUTION NO. 21-8  
A RESOLUTION DECLARING THE INTENT OF THE CITY OF  
CASPER, WYOMING, TO CREATE A LOCAL ASSESSMENT  
DISTRICT NO. 158 IN SAID CITY; TO AUTHORIZE THE  
CONSTRUCTION OF LOCAL IMPROVEMENTS THEREIN;  
AND TO ASSESS THE COST OR PORTION THEREOF ON THE  
PROPERTY BENEFITTED THEREBY.

RESOLUTION NO. 21-9  
A RESOLUTION AUTHORIZING A MEMORANDUM OF  
UNDERSTANDING WITH NATRONA COUNTY, WYOMING  
FOR THE COATES ROAD SURFACE IMPROVEMENTS  
PROJECT.

Councilmember Pollock presented the foregoing four (4) resolutions for adoption. Seconded by Councilmember Knell. Motion passed.

10. MINUTE ACTION– CONSENT

Moved by Councilmember Engebretsen, seconded by Councilmember Gamroth, to, by consent minute action, authorize the purchase of one (1) new fire chassis and body from MaxFire Firefighting Solutions, in the total amount of \$628,004, before trade and authorize appointments to the Council's Boards and Commissions. Motion passed.

11. INTRODUCTION OF MEASURES AND PROPOSALS

Councilmember Knell shared concerns with the following items: parking along 12<sup>th</sup> and 13<sup>th</sup> Streets, a new Police station, facility conditions at the Speedway, and the tobacco ordinance. Councilmember Pollock spoke about transparency and use of the consent agenda to pass items as well as snow removal at bus stops. Mayor Freel asked if more information could be provided at a work session regarding the consent agenda, and City Attorney Henley stated that would be fine. Councilmember Cathey and Vice Mayor Pacheco spoke about the COVID-19 pandemic.

City Manager Napier asked for direction on bringing the Police station item and the parking along one-ways issue forward to a work session. Mayor Freel indicated that these each should be set for a future work session.

Mayor Freel spoke about the unified command that was a joint effort to manage the pandemic situation. He suggested that we exit from the unified command and let the Natrona County Health Department manage things going forward. Councilmembers Knell and Pollock spoke on the matter. City Manager Napier provided more information on the process of standing down from the effort. Council provided support for staff to prepare a resolution for the City to step down from the command.

12. ADJOURN INTO EXECUTIVE SESSION

Mayor Freel noted the next meetings of the City Council will be a work session to be held at 4:30 p.m., Tuesday, January 26, 2021, in the Council Chambers; and, a regular Council meeting to be held at 6:00 p.m., Tuesday, February 2, 2021, in the Council Chambers.

At 7:08 p.m., it was moved Councilmember Knell, seconded by Councilmember Pollock, to adjourn into executive session to discuss personnel. Motion passed.

At 7:55 p.m., it was moved by Councilmember Cathey, seconded by Councilmember Knell, to adjourn the executive session. Motion passed.

13. ADJOURNMENT

At 7:55 p.m., it was moved by Councilmember Cathey, seconded by Vice Mayor Pacheco, to adjourn the regular Council meeting. Motion passed.

ATTEST:

CITY OF CASPER, WYOMING  
A Municipal Corporation

\_\_\_\_\_  
Fleur Tremel  
City Clerk

\_\_\_\_\_  
Steven K. Freel  
Mayor

# City of Casper - Bills and Claims for February 02, 2021

## 0970 CED

0970 CED	Traffic Control	Electric terminals for signal repairs	\$32.00
----------	-----------------	---------------------------------------	---------

<i>0970 CED - Total For Traffic Control</i>			<i>\$32.00</i>
---	--	--	----------------

<b>0970 CED - ALL DEPARTMENTS</b>			<b>\$32.00</b>
-----------------------------------	--	--	----------------

## 71 CONSTRUCTION, INC

71 CONSTRUCTION, INC	Capital Projects Fund	Retainage	\$20,724.93
----------------------	-----------------------	-----------	-------------

71 CONSTRUCTION, INC	Capital Projects Fund	Midwest Elm to Walnut Construc	186,524.38
----------------------	-----------------------	--------------------------------	------------

<i>71 CONSTRUCTION, INC - Total For Capital Projects Fund</i>			<i>\$207,249.31</i>
---	--	--	---------------------

<b>71 CONSTRUCTION, INC - ALL DEPARTMENTS</b>			<b>\$207,249.31</b>
---	--	--	---------------------

## A.M.B.I. & SHIPPING,

A.M.B.I. & SHIPPING,	Customer Service	Postage	\$1,042.50
----------------------	------------------	---------	------------

A.M.B.I. & SHIPPING,	Customer Service	Postage	\$423.40
----------------------	------------------	---------	----------

<i>A.M.B.I. &amp; SHIPPING, - Total For Customer Service</i>			<i>\$1,465.90</i>
--	--	--	-------------------

A.M.B.I. & SHIPPING,	Planning	Postage	\$226.10
----------------------	----------	---------	----------

<i>A.M.B.I. &amp; SHIPPING, - Total For Planning</i>			<i>\$226.10</i>
--	--	--	-----------------

A.M.B.I. & SHIPPING,	Refuse - Residential	Postage	\$19.92
----------------------	----------------------	---------	---------

<i>A.M.B.I. &amp; SHIPPING, - Total For Refuse - Residential</i>			<i>\$19.92</i>
--	--	--	----------------

<b>A.M.B.I. &amp; SHIPPING, - ALL DEPARTMENTS</b>			<b>\$1,711.92</b>
---	--	--	-------------------

## AAA LANDSCAPING

AAA LANDSCAPING	Balefill - Disposal & Landfill	Mowing & Trimming	\$660.00
-----------------	--------------------------------	-------------------	----------

<i>AAA LANDSCAPING - Total For Balefill - Disposal &amp; Landfill</i>			<i>\$660.00</i>
---	--	--	-----------------

<b>AAA LANDSCAPING - ALL DEPARTMENTS</b>			<b>\$660.00</b>
--	--	--	-----------------

## ADBAY.COM

ADBAY.COM	Police Administration	Adbay contract for recruitment	\$3,702.50
-----------	-----------------------	--------------------------------	------------

ADBAY.COM	Police Administration	Adbay contract for recruitment	\$400.00
-----------	-----------------------	--------------------------------	----------

<i>ADBAY.COM - Total For Police Administration</i>			<i>\$4,102.50</i>
--	--	--	-------------------



**ADBAY.COM - ALL DEPARTMENTS** \$4,102.50

**ADECCO USA, INC.**

ADECCO USA, INC.	Balefill - Baler Processing	Contract labor	\$552.90
ADECCO USA, INC.	Balefill - Baler Processing	Contract Labor	\$552.90
ADECCO USA, INC.	Balefill - Baler Processing	Contract Labor	\$465.60

*ADECCO USA, INC. - Total For Balefill - Baler Processing* \$1,571.40

**ADECCO USA, INC. - ALL DEPARTMENTS** \$1,571.40

**ADOBE ACROPRO SUBS**

ADOBE ACROPRO SUBS	City Manager	Adobe Acrobat Subscription	\$14.99
--------------------	--------------	----------------------------	---------

*ADOBE ACROPRO SUBS - Total For City Manager* \$14.99

**ADOBE ACROPRO SUBS - ALL DEPARTMENTS** \$14.99

**ADOBE CREATIVE CLOUD**

ADOBE CREATIVE CLOUD	River Volunteer Events	ADOBE CREATIVE CLOUD - BCOYLE	\$52.99
ADOBE CREATIVE CLOUD	River Volunteer Events	ADOBE CREATIVE CLOUD - BCOYLE	\$52.99

*ADOBE CREATIVE CLOUD - Total For River Volunteer Events* \$105.98

**ADOBE CREATIVE CLOUD - ALL DEPARTMENTS** \$105.98

**AEDLAND.COM**

AEDLAND.COM	Fire-EMS Operations	AED Battery	\$251.75
-------------	---------------------	-------------	----------

*AEDLAND.COM - Total For Fire-EMS Operations* \$251.75

**AEDLAND.COM - ALL DEPARTMENTS** \$251.75

**AHERN RENTALS INC**

AHERN RENTALS INC	Refuse - Residential	Soap	\$541.40
AHERN RENTALS INC	Refuse - Residential	Credit memo	(\$45.00)

*AHERN RENTALS INC - Total For Refuse - Residential* \$496.40

**AHERN RENTALS INC - ALL DEPARTMENTS** \$496.40

## AIR SOLUTIONS INC

AIR SOLUTIONS INC	Buildings & Structures Fund	Field Service	\$570.00
<i>AIR SOLUTIONS INC - Total For Buildings &amp; Structures Fund</i>			<i>\$570.00</i>
<b>AIR SOLUTIONS INC - ALL DEPARTMENTS</b>			<b>\$570.00</b>

## AIRGAS USA LLC

AIRGAS USA LLC	Balefill - Baler Processing	Supplies	\$156.03
AIRGAS USA LLC	Balefill - Baler Processing	Supplies	\$56.58
AIRGAS USA LLC	Balefill - Baler Processing	Supplies	\$131.00
AIRGAS USA LLC	Balefill - Baler Processing	Supplies	\$101.69
AIRGAS USA LLC	Balefill - Baler Processing	Supplies	\$237.80
AIRGAS USA LLC	Balefill - Baler Processing	Supplies	\$23.90
AIRGAS USA LLC	Balefill - Baler Processing	Bottle Refill	\$44.71
AIRGAS USA LLC	Balefill - Baler Processing	Supplies	\$60.00
AIRGAS USA LLC	Balefill - Baler Processing	Supplies	\$79.50
AIRGAS USA LLC	Balefill - Baler Processing	Supplies	\$542.97
AIRGAS USA LLC	Balefill - Baler Processing	Supplies	\$290.80
AIRGAS USA LLC	Balefill - Baler Processing	Supplies	\$88.11
<i>AIRGAS USA LLC - Total For Balefill - Baler Processing</i>			<i>\$1,813.09</i>
<b>AIRGAS USA LLC - ALL DEPARTMENTS</b>			<b>\$1,813.09</b>

## AIRGAS USA, LLC

AIRGAS USA, LLC	Buildings & Structures Fund	Supplies to repair drain at Events Center	\$20.29
<i>AIRGAS USA, LLC - Total For Buildings &amp; Structures Fund</i>			<i>\$20.29</i>
<b>AIRGAS USA, LLC - ALL DEPARTMENTS</b>			<b>\$20.29</b>

## ALBERTSONS #0060

ALBERTSONS #0060	Fire-EMS Administration	Water for Admin	\$5.98
<i>ALBERTSONS #0060 - Total For Fire-EMS Administration</i>			<i>\$5.98</i>
<b>ALBERTSONS #0060 - ALL DEPARTMENTS</b>			<b>\$5.98</b>

## ALBERTSONS #0062

ALBERTSONS #0062	Balefill - Disposal & Landfill	COFFEE	\$8.98
<i>ALBERTSONS #0062 - Total For Balefill - Disposal &amp; Landfill</i>			<i>\$8.98</i>
<b>ALBERTSONS #0062 - ALL DEPARTMENTS</b>			<b>\$8.98</b>

## ALL OUT FIRE EXTINGU

ALL OUT FIRE EXTINGU	Cemetery	DETECTIVE AGENCIES & PROTECTIVE AGENCY,A	\$80.00
<i>ALL OUT FIRE EXTINGU - Total For Cemetery</i>			<i>\$80.00</i>
<b>ALL OUT FIRE EXTINGU - ALL DEPARTMENTS</b>			<b>\$80.00</b>

## ALSCO

ALSCO	Balefill - Baler Processing	Professional Laundry Services	\$104.48
ALSCO	Balefill - Baler Processing	Laundry services	\$104.48
<i>ALSCO - Total For Balefill - Baler Processing</i>			<i>\$208.96</i>
ALSCO	Balefill - Disposal & Landfill	Rag cleaning service	\$53.25
ALSCO	Balefill - Disposal & Landfill	Mat Services	\$53.25
<i>ALSCO - Total For Balefill - Disposal &amp; Landfill</i>			<i>\$106.50</i>
ALSCO	Police Federal Grants	Laundry	\$15.00
ALSCO	Police Federal Grants	Laundry	\$15.00
ALSCO	Police Federal Grants	Laundry	\$15.00
<i>ALSCO - Total For Police Federal Grants</i>			<i>\$45.00</i>
ALSCO	Refuse - Residential	Professional Laundry Services	\$85.56
ALSCO	Refuse - Residential	Laundry services	\$85.56
<i>ALSCO - Total For Refuse - Residential</i>			<i>\$171.12</i>
ALSCO	Sewer Wastewater Collection	Professional Laundry Services	\$63.66
ALSCO	Sewer Wastewater Collection	Professional Laundry Services	\$63.66
ALSCO	Sewer Wastewater Collection	Laundry services	\$63.66
ALSCO	Sewer Wastewater Collection	Professional Laundry Services	\$63.66
ALSCO	Sewer Wastewater Collection	Professional Laundry Services	\$63.66
<i>ALSCO - Total For Sewer Wastewater Collection</i>			<i>\$318.30</i>
ALSCO	WWTP Operations	LAUNDRY, CLEANING, AND GARMENT SERVICES	\$775.58
<i>ALSCO - Total For WWTP Operations</i>			<i>\$775.58</i>
<b>ALSCO - ALL DEPARTMENTS</b>			<b>\$1,625.46</b>

## ALTITUDE RECYCLING E

ALTITUDE RECYCLING E	Balefill - Baler Processing	Services	\$1,995.00
ALTITUDE RECYCLING E	Balefill - Baler Processing	Replace N. Baler Wear Plates	\$29,500.00
ALTITUDE RECYCLING E	Balefill - Baler Processing	Services	\$1,995.00
ALTITUDE RECYCLING E	Balefill - Baler Processing	Services	\$1,995.00
ALTITUDE RECYCLING E	Balefill - Baler Processing	Services	\$1,995.00

*ALTITUDE RECYCLING E - Total For Balefill - Baler Processing* \$37,480.00

**ALTITUDE RECYCLING E - ALL DEPARTMENTS** \$37,480.00

## AMAZON.COM UT9WY4X83

AMAZON.COM UT9WY4X83	Metro Animal Control	uniform boot chains	\$189.90
----------------------	----------------------	---------------------	----------

*AMAZON.COM UT9WY4X83 - Total For Metro Animal Control* \$189.90

**AMAZON.COM UT9WY4X83 - ALL DEPARTMENTS** \$189.90

## AMAZON.COM YR76B31P3

AMAZON.COM YR76B31P3	Police Career Services	uniform boot chains	\$157.50
----------------------	------------------------	---------------------	----------

*AMAZON.COM YR76B31P3 - Total For Police Career Services* \$157.50

**AMAZON.COM YR76B31P3 - ALL DEPARTMENTS** \$157.50

## AMERICAN ASSOC OF CO

AMERICAN ASSOC OF CO	Code Enforcement	AACE Membership Renewal - K May	\$75.00
AMERICAN ASSOC OF CO	Code Enforcement	AACE Membership Renewal - Cheryl Metzger	\$75.00
AMERICAN ASSOC OF CO	Code Enforcement	AACE Membership Renewal - A Jividen	\$75.00

*AMERICAN ASSOC OF CO - Total For Code Enforcement* \$225.00

**AMERICAN ASSOC OF CO - ALL DEPARTMENTS** \$225.00

## AMERICAN EQUIPMENT L

AMERICAN EQUIPMENT L	Regional Water Operations	Crane inspections for 2020	\$2,158.75
----------------------	---------------------------	----------------------------	------------

*AMERICAN EQUIPMENT L - Total For Regional Water Operations* \$2,158.75

**AMERICAN EQUIPMENT L - ALL DEPARTMENTS** \$2,158.75

## AMERICAN HEART SHOPC

AMERICAN HEART SHOPC	Fire-EMS Training	ACLS Course	\$132.00
<i>AMERICAN HEART SHOPC - Total For Fire-EMS Training</i>			<i>\$132.00</i>
<b>AMERICAN HEART SHOPC - ALL DEPARTMENTS</b>			<b>\$132.00</b>

## AMERIGAS - CASPER

AMERIGAS - CASPER	Balefill - Disposal & Landfill	Supplies	\$210.79
AMERIGAS - CASPER	Balefill - Disposal & Landfill	Fork Lift fuel	\$207.86
<i>AMERIGAS - CASPER - Total For Balefill - Disposal &amp; Landfill</i>			<i>\$418.65</i>
AMERIGAS - CASPER	WWTP Operations	Propane for temp generators	\$6,587.37
AMERIGAS - CASPER	WWTP Operations	Propane for temp generators	\$6,215.49
AMERIGAS - CASPER	WWTP Operations	Propane for temp generators	\$18,155.49
<i>AMERIGAS - CASPER - Total For WWTP Operations</i>			<i>\$30,958.35</i>
<b>AMERIGAS - CASPER - ALL DEPARTMENTS</b>			<b>\$31,377.00</b>

## AMZN Mktp US

AMZN Mktp US	Parks - Urban Forestry	Tree Fertilizer	\$15.98
AMZN Mktp US	Parks - Urban Forestry	Tree Fertilizer	\$15.52
<i>AMZN Mktp US - Total For Parks - Urban Forestry</i>			<i>\$31.50</i>
AMZN Mktp US	Rec Center - Classes	Bows for cheerleading class	\$20.97
<i>AMZN Mktp US - Total For Rec Center - Classes</i>			<i>\$20.97</i>
AMZN Mktp US	Water Distribution	Weather station	\$289.99
<i>AMZN Mktp US - Total For Water Distribution</i>			<i>\$289.99</i>
<b>AMZN Mktp US - ALL DEPARTMENTS</b>			<b>\$342.46</b>

## ARROWHEAD HEATING &

ARROWHEAD HEATING &	Balefill - Baler Processing	Services	\$198.70
ARROWHEAD HEATING &	Balefill - Baler Processing	Services	\$90.00
<i>ARROWHEAD HEATING &amp; - Total For Balefill - Baler Processing</i>			<i>\$288.70</i>
ARROWHEAD HEATING &	Balefill - Disposal & Landfill	HVAC services	\$121.67
ARROWHEAD HEATING &	Balefill - Disposal & Landfill	Services	\$90.00
<i>ARROWHEAD HEATING &amp; - Total For Balefill - Disposal &amp; Landfill</i>			<i>\$211.67</i>

**ARROWHEAD HEATING & - ALL DEPARTMENTS**

\$500.37

**AT&T BILL PAYMENT**

AT&T BILL PAYMENT	Code Enforcement	SIM CARDS FOR BUILDING INSPECTORS	\$200.20
<i>AT&amp;T BILL PAYMENT - Total For Code Enforcement</i>			\$200.20
AT&T BILL PAYMENT	Fire-EMS Administration	November 2020	\$511.14
<i>AT&amp;T BILL PAYMENT - Total For Fire-EMS Administration</i>			\$511.14
<b>AT&amp;T BILL PAYMENT - ALL DEPARTMENTS</b>			<b>\$711.34</b>

**ATLANTIC ELECTRIC, I**

ATLANTIC ELECTRIC, I	Property Insurance Fund	Replace pole claim #2020036	\$4,400.00
<i>ATLANTIC ELECTRIC, I - Total For Property Insurance Fund</i>			\$4,400.00
ATLANTIC ELECTRIC, I	Traffic Control	FY21-24 Luminaire Services	\$11,257.12
<i>ATLANTIC ELECTRIC, I - Total For Traffic Control</i>			\$11,257.12
<b>ATLANTIC ELECTRIC, I - ALL DEPARTMENTS</b>			<b>\$15,657.12</b>

**ATLAS OFFICE PRODUCT**

ATLAS OFFICE PRODUCT	Balefill - Baler Processing	Label Tape	\$26.20
<i>ATLAS OFFICE PRODUCT - Total For Balefill - Baler Processing</i>			\$26.20
ATLAS OFFICE PRODUCT	Balefill - Disposal & Landfill	Office supplies	\$24.47
ATLAS OFFICE PRODUCT	Balefill - Disposal & Landfill	Printer cartridge	\$101.79
ATLAS OFFICE PRODUCT	Balefill - Disposal & Landfill	Printer cartridge	\$127.06
<i>ATLAS OFFICE PRODUCT - Total For Balefill - Disposal &amp; Landfill</i>			\$253.32
ATLAS OFFICE PRODUCT	Balefill - Diversion & Special	Office supplies	\$449.46
<i>ATLAS OFFICE PRODUCT - Total For Balefill - Diversion &amp; Special</i>			\$449.46
ATLAS OFFICE PRODUCT	City Manager	Toner for printers	\$1,416.15
<i>ATLAS OFFICE PRODUCT - Total For City Manager</i>			\$1,416.15
ATLAS OFFICE PRODUCT	Information Services	New Office Chair	\$225.23
<i>ATLAS OFFICE PRODUCT - Total For Information Services</i>			\$225.23
ATLAS OFFICE PRODUCT	Municipal Court	Office supplies	\$20.00
ATLAS OFFICE PRODUCT	Municipal Court	Office Supplies	\$116.90
<i>ATLAS OFFICE PRODUCT - Total For Municipal Court</i>			\$136.90
ATLAS OFFICE PRODUCT	Planning	3 Name Plates for new Planning & Zoning Com	\$19.35

<i>ATLAS OFFICE PRODUCT - Total For Planning</i>			<i>\$19.35</i>
ATLAS OFFICE PRODUCT	Police Administration	Office Supplies	\$18.59
ATLAS OFFICE PRODUCT	Police Administration	Office Supplies	\$514.98
ATLAS OFFICE PRODUCT	Police Administration	Office Supplies	\$379.00
ATLAS OFFICE PRODUCT	Police Administration	Office Supplies	\$3.10
ATLAS OFFICE PRODUCT	Police Administration	Office supplies	\$953.47
ATLAS OFFICE PRODUCT	Police Administration	Office supplies	\$27.95
ATLAS OFFICE PRODUCT	Police Administration	Office Supplies	\$514.89
ATLAS OFFICE PRODUCT	Police Administration	Office Supplies	\$21.99
ATLAS OFFICE PRODUCT	Police Administration	Office Supplies	\$227.25
<i>ATLAS OFFICE PRODUCT - Total For Police Administration</i>			<i>\$2,661.22</i>
ATLAS OFFICE PRODUCT	Police Investigations	Office Supplies	\$415.01
ATLAS OFFICE PRODUCT	Police Investigations	Office Supplies	\$167.43
ATLAS OFFICE PRODUCT	Police Investigations	Office Supplies	\$3.99
<i>ATLAS OFFICE PRODUCT - Total For Police Investigations</i>			<i>\$586.43</i>
ATLAS OFFICE PRODUCT	Public Safety Communication	Office Supplies	\$315.99
<i>ATLAS OFFICE PRODUCT - Total For Public Safety Communications</i>			<i>\$315.99</i>
ATLAS OFFICE PRODUCT	Regional Water Operations	Office Supply	\$14.80
ATLAS OFFICE PRODUCT	Regional Water Operations	Office Supply	\$140.46
ATLAS OFFICE PRODUCT	Regional Water Operations	Office supply	\$20.90
<i>ATLAS OFFICE PRODUCT - Total For Regional Water Operations</i>			<i>\$176.16</i>
ATLAS OFFICE PRODUCT	Sewer Administration	Office Supplies	\$25.97
<i>ATLAS OFFICE PRODUCT - Total For Sewer Administration</i>			<i>\$25.97</i>
ATLAS OFFICE PRODUCT	Water Administration	Office Supplies	\$31.75
<i>ATLAS OFFICE PRODUCT - Total For Water Administration</i>			<i>\$31.75</i>
<b>ATLAS OFFICE PRODUCT - ALL DEPARTMENTS</b>			<b>\$6,324.13</b>

## ATLAS REPRODUCTION

ATLAS REPRODUCTION	Planning	Copies	\$21.00
<i>ATLAS REPRODUCTION - Total For Planning</i>			<i>\$21.00</i>
ATLAS REPRODUCTION	Police Administration	Copies	\$32.07
ATLAS REPRODUCTION	Police Administration	Copies	\$106.30
<i>ATLAS REPRODUCTION - Total For Police Administration</i>			<i>\$138.37</i>
<b>ATLAS REPRODUCTION - ALL DEPARTMENTS</b>			<b>\$159.37</b>

## BACKDRAFT OPCO LLC

BACKDRAFT OPCO LLC	Fire-EMS Administration	2021 Emergency Reporting Subscription	\$11,629.95
<i>BACKDRAFT OPCO LLC - Total For Fire-EMS Administration</i>			<i>\$11,629.95</i>
<b>BACKDRAFT OPCO LLC - ALL DEPARTMENTS</b>			<b>\$11,629.95</b>

## BAILEY'S ACE HARDWAR

BAILEY'S ACE HARDWAR	Balefill - Baler Processing	Supplies	\$16.15
<i>BAILEY'S ACE HARDWAR - Total For Balefill - Baler Processing</i>			<i>\$16.15</i>
BAILEY'S ACE HARDWAR	Refuse - Residential	Cleaning supplies	\$35.97
<i>BAILEY'S ACE HARDWAR - Total For Refuse - Residential</i>			<i>\$35.97</i>
<b>BAILEY'S ACE HARDWAR - ALL DEPARTMENTS</b>			<b>\$52.12</b>

## BAILEYS ACE HDWE

BAILEYS ACE HDWE	Buildings & Structures Fund	Supplies to repair Ice Arena ice machine	\$16.09
BAILEYS ACE HDWE	Buildings & Structures Fund	Supplies for Ice Arena Maintenance	\$9.98
BAILEYS ACE HDWE	Buildings & Structures Fund	Pump repair parts for Metro Animal Shelter	\$14.98
<i>BAILEYS ACE HDWE - Total For Buildings &amp; Structures Fund</i>			<i>\$41.05</i>
BAILEYS ACE HDWE	Fire-EMS Administration	HDMI Cable	\$21.99
<i>BAILEYS ACE HDWE - Total For Fire-EMS Administration</i>			<i>\$21.99</i>
BAILEYS ACE HDWE	Fire-EMS Operations	Station Supplies	\$23.98
<i>BAILEYS ACE HDWE - Total For Fire-EMS Operations</i>			<i>\$23.98</i>
BAILEYS ACE HDWE	Hogadon - Operations	HARDWARE Magic Carpet	\$39.86
<i>BAILEYS ACE HDWE - Total For Hogadon - Operations</i>			<i>\$39.86</i>
BAILEYS ACE HDWE	WWTP Operations	Storage tote	\$10.99
<i>BAILEYS ACE HDWE - Total For WWTP Operations</i>			<i>\$10.99</i>
<b>BAILEYS ACE HDWE - ALL DEPARTMENTS</b>			<b>\$137.87</b>

## BAR-D SIGNS, INC.

BAR-D SIGNS, INC.	Balefill - Diversion & Special	Signage	\$168.00
<i>BAR-D SIGNS, INC. - Total For Balefill - Diversion &amp; Special</i>			<i>\$168.00</i>
BAR-D SIGNS, INC.	Refuse - Commercial	Signage	\$1,160.00
<i>BAR-D SIGNS, INC. - Total For Refuse - Commercial</i>			<i>\$1,160.00</i>



**BAR-D SIGNS, INC. - ALL DEPARTMENTS**

\$1,328.00

**BEST BUY**

BEST BUY	Fire-EMS Administration	New charging cables for CH4 rig	\$29.98
----------	-------------------------	---------------------------------	---------

<i>BEST BUY - Total For Fire-EMS Administration</i>			\$29.98
---	--	--	---------

**BEST BUY - ALL DEPARTMENTS**

\$29.98

**BESTBUYCOM8063591545**

BESTBUYCOM8063591545	Social Community Services	TECH 2 - IPADS for Inspectors	\$902.98
----------------------	---------------------------	-------------------------------	----------

<i>BESTBUYCOM8063591545 - Total For Social Community Services</i>			\$902.98
---	--	--	----------

**BESTBUYCOM8063591545 - ALL DEPARTMENTS**

\$902.98

**BESTBUYCOM8064126918**

BESTBUYCOM8064126918	Information Services	HDMI to Lightning Adapter for Chambers	\$54.99
----------------------	----------------------	--	---------

<i>BESTBUYCOM8064126918 - Total For Information Services</i>			\$54.99
--	--	--	---------

**BESTBUYCOM8064126918 - ALL DEPARTMENTS**

\$54.99

**BIG HORN TIRE**

BIG HORN TIRE	Balefill - Disposal & Landfill	Tire Repair	\$575.00
---------------	--------------------------------	-------------	----------

BIG HORN TIRE	Balefill - Disposal & Landfill	REPLACEMENT LANDFILL LOADER TIRES	\$22,826.76
---------------	--------------------------------	-----------------------------------	-------------

BIG HORN TIRE	Balefill - Disposal & Landfill	Tire repairs	\$243.00
---------------	--------------------------------	--------------	----------

BIG HORN TIRE	Balefill - Disposal & Landfill	Tire repair	\$750.00
---------------	--------------------------------	-------------	----------

<i>BIG HORN TIRE - Total For Balefill - Disposal &amp; Landfill</i>			\$24,394.76
---	--	--	-------------

**BIG HORN TIRE - ALL DEPARTMENTS**

\$24,394.76

**BLACK HILLS ENERGY**

BLACK HILLS ENERGY	Aquatics - Operations	7584 6122 74	\$4,145.30
--------------------	-----------------------	--------------	------------

<i>BLACK HILLS ENERGY - Total For Aquatics - Operations</i>			\$4,145.30
---	--	--	------------

BLACK HILLS ENERGY	Aquatics - Pool	9723 1947 06	\$724.14
--------------------	-----------------	--------------	----------

<i>BLACK HILLS ENERGY - Total For Aquatics - Pool</i>			\$724.14
---	--	--	----------

BLACK HILLS ENERGY	Balefill - Disposal & Landfill	7538 8605 37	\$29.59
--------------------	--------------------------------	--------------	---------

BLACK HILLS ENERGY	Balefill - Disposal & Landfill	1919 8530 97	\$9,934.38
--------------------	--------------------------------	--------------	------------

<i>BLACK HILLS ENERGY - Total For Balefill - Disposal &amp; Landfill</i>			\$9,963.97
BLACK HILLS ENERGY	Buildings & Structures Fund	8545 6521 02	\$363.04
<i>BLACK HILLS ENERGY - Total For Buildings &amp; Structures Fund</i>			\$363.04
BLACK HILLS ENERGY	Cemetery	9629 0042 60	\$585.87
<i>BLACK HILLS ENERGY - Total For Cemetery</i>			\$585.87
BLACK HILLS ENERGY	City Center Building	8545 6521 02	\$165.62
<i>BLACK HILLS ENERGY - Total For City Center Building</i>			\$165.62
BLACK HILLS ENERGY	City Hall	6837 4281 65	\$410.21
<i>BLACK HILLS ENERGY - Total For City Hall</i>			\$410.21
BLACK HILLS ENERGY	Fire-EMS Administration	3267 4234 58	\$763.97
BLACK HILLS ENERGY	Fire-EMS Administration	1783 9430 41	\$3,558.54
<i>BLACK HILLS ENERGY - Total For Fire-EMS Administration</i>			\$4,322.51
BLACK HILLS ENERGY	Fleet Maintenance Fund	5293 6421 13	\$5,208.63
<i>BLACK HILLS ENERGY - Total For Fleet Maintenance Fund</i>			\$5,208.63
BLACK HILLS ENERGY	Ft. Caspar Museum	9861 5264 23	\$725.06
<i>BLACK HILLS ENERGY - Total For Ft. Caspar Museum</i>			\$725.06
BLACK HILLS ENERGY	Golf - Operations	6566 7661 30	\$611.94
<i>BLACK HILLS ENERGY - Total For Golf - Operations</i>			\$611.94
BLACK HILLS ENERGY	Marathon Building	8545 6521 02	\$992.89
<i>BLACK HILLS ENERGY - Total For Marathon Building</i>			\$992.89
BLACK HILLS ENERGY	Metro Animal Shelter	9630 2229 58	\$1,823.14
<i>BLACK HILLS ENERGY - Total For Metro Animal Shelter</i>			\$1,823.14
BLACK HILLS ENERGY	Miller St. Dormitory	8545 6521 02	\$138.22
<i>BLACK HILLS ENERGY - Total For Miller St. Dormitory</i>			\$138.22
BLACK HILLS ENERGY	Parks - Parks Maint.	2076 2356 87	\$83.76
<i>BLACK HILLS ENERGY - Total For Parks - Parks Maint.</i>			\$83.76
BLACK HILLS ENERGY	Rec Center - Operations	4400 2150 46	\$1,621.62
<i>BLACK HILLS ENERGY - Total For Rec Center - Operations</i>			\$1,621.62
BLACK HILLS ENERGY	Regional Water Operations	7513 1659 94	\$7,095.63
<i>BLACK HILLS ENERGY - Total For Regional Water Operations</i>			\$7,095.63
BLACK HILLS ENERGY	Sewer Wastewater Collection	6405 5357 61	\$43.03
<i>BLACK HILLS ENERGY - Total For Sewer Wastewater Collection</i>			\$43.03
BLACK HILLS ENERGY	Water Distribution	0295 5402 18	\$1,337.01
<i>BLACK HILLS ENERGY - Total For Water Distribution</i>			\$1,337.01
BLACK HILLS ENERGY	WWTP Operations	5541 2887 44	\$12,400.59
<i>BLACK HILLS ENERGY - Total For WWTP Operations</i>			\$12,400.59

**BLACK HILLS ENERGY - ALL DEPARTMENTS** \$52,762.18

### **BLAKEMAN PROPANE**

BLAKEMAN PROPANE Hogadon - Operations Winter Propane \$8,236.02

*BLAKEMAN PROPANE - Total For Hogadon - Operations* \$8,236.02

**BLAKEMAN PROPANE - ALL DEPARTMENTS** \$8,236.02

### **BLOEDORN LUMBER**

BLOEDORN LUMBER Buildings & Structures Fund Credit memo (\$25.99)

BLOEDORN LUMBER Buildings & Structures Fund Concrete \$109.44

BLOEDORN LUMBER Buildings & Structures Fund Supplies \$79.36

BLOEDORN LUMBER Buildings & Structures Fund Supplies \$10.56

*BLOEDORN LUMBER - Total For Buildings & Structures Fund* \$173.37

**BLOEDORN LUMBER - ALL DEPARTMENTS** \$173.37

### **BRIDGER STEEL CASPER**

BRIDGER STEEL CASPER Golf - Operations Supplies for Golf Course Clubhouse Remodel \$2.43

BRIDGER STEEL CASPER Golf - Operations Supplies for Golf Course Clubhouse Remodel \$1,044.47

*BRIDGER STEEL CASPER - Total For Golf - Operations* \$1,046.90

**BRIDGER STEEL CASPER - ALL DEPARTMENTS** \$1,046.90

### **CANVA 02930-1176927**

CANVA 02930-1176927 Parks - Parks Maint. PHOTOGRAPHIC STUDIOS \$12.95

*CANVA 02930-1176927 - Total For Parks - Parks Maint.* \$12.95

**CANVA 02930-1176927 - ALL DEPARTMENTS** \$12.95

### **CAROLINA SOFTWARE**

CAROLINA SOFTWARE Balefill - Disposal & Landfill Software support \$250.00

*CAROLINA SOFTWARE - Total For Balefill - Disposal & Landfill* \$250.00

**CAROLINA SOFTWARE - ALL DEPARTMENTS** \$250.00

## CASELLE, INC.

CASELLE, INC.	Customer Service	Services	\$75.00
<i>CASELLE, INC. - Total For Customer Service</i>			<i>\$75.00</i>
<b>CASELLE, INC. - ALL DEPARTMENTS</b>			<b>\$75.00</b>

## CASPER AREA CHAMBER

CASPER AREA CHAMBER	City Council	Economic Update Webinar	\$10.00
CASPER AREA CHAMBER	City Council	Economic Update Webinar	\$10.00
<i>CASPER AREA CHAMBER - Total For City Council</i>			<i>\$20.00</i>
<b>CASPER AREA CHAMBER - ALL DEPARTMENTS</b>			<b>\$20.00</b>

## CASPER AREA TRANSPOR

CASPER AREA TRANSPOR	Capital Projects Fund	1%#16 Funding CATC Bus Tokens	\$11,210.00
<i>CASPER AREA TRANSPOR - Total For Capital Projects Fund</i>			<i>\$11,210.00</i>
<b>CASPER AREA TRANSPOR - ALL DEPARTMENTS</b>			<b>\$11,210.00</b>

## CASPER ELECTRIC, INC

CASPER ELECTRIC, INC	Capital Projects Fund	CEC Fire Alarm Replacement	\$29,331.00
<i>CASPER ELECTRIC, INC - Total For Capital Projects Fund</i>			<i>\$29,331.00</i>
CASPER ELECTRIC, INC	Perpetual Care Building Trust	CEC Fire Alarm Replacement	132,920.50
<i>CASPER ELECTRIC, INC - Total For Perpetual Care Building Trust</i>			<i>\$132,920.50</i>
<b>CASPER ELECTRIC, INC - ALL DEPARTMENTS</b>			<b>\$162,251.50</b>

## CASPER FIRE EXTINGUI

CASPER FIRE EXTINGUI	Fleet Maintenance Fund	Certification - Garage	\$534.00
<i>CASPER FIRE EXTINGUI - Total For Fleet Maintenance Fund</i>			<i>\$534.00</i>
<b>CASPER FIRE EXTINGUI - ALL DEPARTMENTS</b>			<b>\$534.00</b>

## CASPER STAR TRIBUNE

CASPER STAR TRIBUNE	Hogadon - Operations	NEWS DEALERS AND NEWSSTANDS	\$200.00
<i>CASPER STAR TRIBUNE - Total For Hogadon - Operations</i>			<i>\$200.00</i>

CASPER STAR TRIBUNE	Sewer Wastewater Collection	NEWS DEALERS AND NEWSSTANDS	\$250.00
<i>CASPER STAR TRIBUNE - Total For Sewer Wastewater Collection</i>			<i>\$250.00</i>
CASPER STAR TRIBUNE	WWTP Operations	NEWS DEALERS AND NEWSSTANDS	\$250.00
<i>CASPER STAR TRIBUNE - Total For WWTP Operations</i>			<i>\$250.00</i>
<b>CASPER STAR TRIBUNE - ALL DEPARTMENTS</b>			<b>\$700.00</b>

## CASPER STAR-TRIBUNE,

CASPER STAR-TRIBUNE,	Balefill - Disposal & Landfill	Standard Ad for bid	\$615.44
<i>CASPER STAR-TRIBUNE, - Total For Balefill - Disposal &amp; Landfill</i>			<i>\$615.44</i>
CASPER STAR-TRIBUNE,	Capital Projects Fund	Ad for Bids	\$605.96
CASPER STAR-TRIBUNE,	Capital Projects Fund	Final Pay Ad	\$156.24
CASPER STAR-TRIBUNE,	Capital Projects Fund	Final Pay Ad	\$232.60
CASPER STAR-TRIBUNE,	Capital Projects Fund	Final Pay Ad	\$227.86
<i>CASPER STAR-TRIBUNE, - Total For Capital Projects Fund</i>			<i>\$1,222.66</i>
CASPER STAR-TRIBUNE,	City Clerk	Council Minutes	\$1,025.80
CASPER STAR-TRIBUNE,	City Clerk	Council Proceedngs	\$130.54
CASPER STAR-TRIBUNE,	City Clerk	Council proceedings	\$209.54
<i>CASPER STAR-TRIBUNE, - Total For City Clerk</i>			<i>\$1,365.88</i>
CASPER STAR-TRIBUNE,	Planning	Legal Notice	\$114.64
CASPER STAR-TRIBUNE,	Planning	Legal Notice	\$78.30
CASPER STAR-TRIBUNE,	Planning	Notice The Casper City Council	\$102.20
<i>CASPER STAR-TRIBUNE, - Total For Planning</i>			<i>\$295.14</i>
CASPER STAR-TRIBUNE,	Rec Center - Operations	Subscription Renewal Acct #156-00013001	\$369.99
<i>CASPER STAR-TRIBUNE, - Total For Rec Center - Operations</i>			<i>\$369.99</i>
CASPER STAR-TRIBUNE,	Refuse - Recycling	Standard Ad for bid	\$615.44
<i>CASPER STAR-TRIBUNE, - Total For Refuse - Recycling</i>			<i>\$615.44</i>
<b>CASPER STAR-TRIBUNE, - ALL DEPARTMENTS</b>			<b>\$4,484.55</b>

## CASPER TIRE

CASPER TIRE	Refuse - Commercial	Flat Repair	\$90.00
<i>CASPER TIRE - Total For Refuse - Commercial</i>			<i>\$90.00</i>
CASPER TIRE	Refuse - Residential	Flat Repair	\$150.00
CASPER TIRE	Refuse - Residential	Flat Repair	\$45.00
<i>CASPER TIRE - Total For Refuse - Residential</i>			<i>\$195.00</i>

**CASPER TIRE - ALL DEPARTMENTS**

\$285.00

**CASPER WINNELSON CO**

CASPER WINNELSON CO	Buildings & Structures Fund	HVAC Repair supplies for Aquatics Center	\$547.00
CASPER WINNELSON CO	Buildings & Structures Fund	Supplies to install bottle filler at Golf Course	\$28.93
CASPER WINNELSON CO	Buildings & Structures Fund	Plumbing repair parts for Miller House	\$28.29
CASPER WINNELSON CO	Buildings & Structures Fund	Supplies to install bottle filler at Golf Course	\$75.49
CASPER WINNELSON CO	Buildings & Structures Fund	Supplies to install bottle filler at Golf Course	\$36.11
CASPER WINNELSON CO	Buildings & Structures Fund	HVAC Repair parts for Aquatics Center	\$307.50
CASPER WINNELSON CO	Buildings & Structures Fund	Supplies to repair drain at Events Center	\$55.92
CASPER WINNELSON CO	Buildings & Structures Fund	Supplies to repair drain at Events Center	\$193.58
CASPER WINNELSON CO	Buildings & Structures Fund	Supplies to install bottle filler at Golf Course	\$18.17
CASPER WINNELSON CO	Buildings & Structures Fund	Pump repair parts for Metro Animal Shelter	\$259.30
CASPER WINNELSON CO	Buildings & Structures Fund	Plumbing repair parts for Aquatics Center	\$29.54
CASPER WINNELSON CO	Buildings & Structures Fund	Plumbing supplies to repair toilet at Ice Arena	\$63.34
CASPER WINNELSON CO	Buildings & Structures Fund	Pump repair supplies for Ice Arena	\$36.80
CASPER WINNELSON CO	Buildings & Structures Fund	Ice Arena maintenance Supplies	\$7.66

---

*CASPER WINNELSON CO - Total For Buildings & Structures Fund* \$1,687.63

CASPER WINNELSON CO	WWTP Operations	Plumbing parts	\$61.40
---------------------	-----------------	----------------	---------

---

*CASPER WINNELSON CO - Total For WWTP Operations* \$61.40

**CASPER WINNELSON CO - ALL DEPARTMENTS**

\$1,749.03

**CENTRAL PAINT & BODY**

CENTRAL PAINT & BODY	Fleet Maintenance Fund	Repairs	\$1,251.30
----------------------	------------------------	---------	------------

---

*CENTRAL PAINT & BODY - Total For Fleet Maintenance Fund* \$1,251.30

**CENTRAL PAINT & BODY - ALL DEPARTMENTS**

\$1,251.30

**CENTRAL WY. RESCUE M**

CENTRAL WY. RESCUE M	Capital Projects Fund	1% #16 Funding Central WY Resc	\$5,832.20
----------------------	-----------------------	--------------------------------	------------

---

*CENTRAL WY. RESCUE M - Total For Capital Projects Fund* \$5,832.20

**CENTRAL WY. RESCUE M - ALL DEPARTMENTS**

\$5,832.20

**CENTURYLINK**

CENTURYLINK	Aquatics - Operations	P-307-111-9950 456M	\$49.01
<i>CENTURYLINK - Total For Aquatics - Operations</i>			<i>\$49.01</i>
CENTURYLINK	Balefill - Disposal & Landfill	P-307-111-9950 456M	\$157.63
<i>CENTURYLINK - Total For Balefill - Disposal &amp; Landfill</i>			<i>\$157.63</i>
CENTURYLINK	Buildings & Structures Fund	P-307-111-9950 456M	\$29.65
<i>CENTURYLINK - Total For Buildings &amp; Structures Fund</i>			<i>\$29.65</i>
CENTURYLINK	Cemetery	P-307-111-9950 456M	\$29.65
<i>CENTURYLINK - Total For Cemetery</i>			<i>\$29.65</i>
CENTURYLINK	City Attorney	P-307-111-9950 456M	\$108.31
<i>CENTURYLINK - Total For City Attorney</i>			<i>\$108.31</i>
CENTURYLINK	City Council	P-307-111-9950 456M	\$29.65
<i>CENTURYLINK - Total For City Council</i>			<i>\$29.65</i>
CENTURYLINK	City Hall	P-307-111-9950 456M	\$19.66
<i>CENTURYLINK - Total For City Hall</i>			<i>\$19.66</i>
CENTURYLINK	City Manager	P-307-111-9950 456M	\$68.98
<i>CENTURYLINK - Total For City Manager</i>			<i>\$68.98</i>
CENTURYLINK	Code Enforcement	P-307-111-9950 456M	\$137.97
<i>CENTURYLINK - Total For Code Enforcement</i>			<i>\$137.97</i>
CENTURYLINK	Customer Service	P-307-111-9950 456M	\$68.98
<i>CENTURYLINK - Total For Customer Service</i>			<i>\$68.98</i>
CENTURYLINK	Engineering	P-307-111-9950 456M	\$137.97
<i>CENTURYLINK - Total For Engineering</i>			<i>\$137.97</i>
CENTURYLINK	Finance	P-307-111-9950 456M	\$157.63
<i>CENTURYLINK - Total For Finance</i>			<i>\$157.63</i>
CENTURYLINK	Fire-EMS Administration	P-307-111-5104 106M	\$3,609.58
CENTURYLINK	Fire-EMS Administration	P-307-111-9950 456M	\$196.96
<i>CENTURYLINK - Total For Fire-EMS Administration</i>			<i>\$3,806.54</i>
CENTURYLINK	Fleet Maintenance Fund	P-307-111-9950 456M	\$127.98
<i>CENTURYLINK - Total For Fleet Maintenance Fund</i>			<i>\$127.98</i>
CENTURYLINK	Ft. Caspar Museum	P-307-111-9950 456M	\$29.65
<i>CENTURYLINK - Total For Ft. Caspar Museum</i>			<i>\$29.65</i>
CENTURYLINK	Golf - Operations	P-307-111-9950 456M	\$29.65
<i>CENTURYLINK - Total For Golf - Operations</i>			<i>\$29.65</i>
CENTURYLINK	Hogadon - Operations	P-307-111-9950 456M	\$98.32
<i>CENTURYLINK - Total For Hogadon - Operations</i>			<i>\$98.32</i>
CENTURYLINK	Human Resources	P-307-111-9950 456M	\$49.32

<i>CENTURYLINK - Total For Human Resources</i>			\$49.32
CENTURYLINK	Ice Arena - Operations	P-307-111-9950 456M	\$39.33
<i>CENTURYLINK - Total For Ice Arena - Operations</i>			\$39.33
CENTURYLINK	Information Services	P-307-111-9950 456M	\$157.63
<i>CENTURYLINK - Total For Information Services</i>			\$157.63
CENTURYLINK	Metro Animal Shelter	P-307-111-9950 456M	\$29.65
CENTURYLINK	Metro Animal Shelter	P-307-234-8116 403 M	\$153.68
<i>CENTURYLINK - Total For Metro Animal Shelter</i>			\$183.33
CENTURYLINK	Municipal Court	P-307-111-9950 456M	\$108.31
<i>CENTURYLINK - Total For Municipal Court</i>			\$108.31
CENTURYLINK	Parks - Parks Maint.	P-307-111-9950 456M	\$108.31
<i>CENTURYLINK - Total For Parks - Parks Maint.</i>			\$108.31
CENTURYLINK	Planning	P-307-111-9950 456M	\$98.32
<i>CENTURYLINK - Total For Planning</i>			\$98.32
CENTURYLINK	Police Administration	P-307-111-5103 060M	\$364.59
CENTURYLINK	Police Administration	P-307-111-9950 456M	\$610.24
<i>CENTURYLINK - Total For Police Administration</i>			\$974.83
CENTURYLINK	Public Safety Communication	P-307-111-5107 160M	\$21,763.48
CENTURYLINK	Public Safety Communication	P-307-111-9950 456M	\$19.66
CENTURYLINK	Public Safety Communication	307-432-*1300 572B	\$1,966.18
<i>CENTURYLINK - Total For Public Safety Communications</i>			\$23,749.32
CENTURYLINK	Rec Center - Operations	P-307-111-9950 456M	\$78.66
<i>CENTURYLINK - Total For Rec Center - Operations</i>			\$78.66
CENTURYLINK	Regional Water Operations	P-307-111-9950 456M	\$39.33
<i>CENTURYLINK - Total For Regional Water Operations</i>			\$39.33
CENTURYLINK	Risk Management	P-307-111-9950 456M	\$29.71
<i>CENTURYLINK - Total For Risk Management</i>			\$29.71
CENTURYLINK	Sewer Administration	307-234-6303 407B	\$202.95
<i>CENTURYLINK - Total For Sewer Administration</i>			\$202.95
CENTURYLINK	Sewer Wastewater Collection	307-472-1129 839B	\$5.49
CENTURYLINK	Sewer Wastewater Collection	307-234-6303 407B	\$144.51
CENTURYLINK	Sewer Wastewater Collection	P-307-111-9950 456M	\$19.66
<i>CENTURYLINK - Total For Sewer Wastewater Collection</i>			\$169.66
CENTURYLINK	Streets	P-307-111-9950 456M	\$68.98
<i>CENTURYLINK - Total For Streets</i>			\$68.98
CENTURYLINK	Water Administration	P-307-111-9950 456M	\$39.33



<i>CENTURYLINK - Total For Water Administration</i>			\$39.33
CENTURYLINK	Water Distribution	P-307-111-9950 456M	\$29.65
<i>CENTURYLINK - Total For Water Distribution</i>			\$29.65
CENTURYLINK	Water Meters	P-307-111-9950 456M	\$58.68
<i>CENTURYLINK - Total For Water Meters</i>			\$58.68
CENTURYLINK	WWTP Operations	P-307-111-9950 456M	\$58.99
<i>CENTURYLINK - Total For WWTP Operations</i>			\$58.99
<b>CENTURYLINK - ALL DEPARTMENTS</b>			<b>\$31,331.87</b>

## CHILD DEVELOPMENT CE

CHILD DEVELOPMENT CE	Capital Projects Fund	1%#16 Funding Child Developmen	\$4,250.00
<i>CHILD DEVELOPMENT CE - Total For Capital Projects Fund</i>			\$4,250.00
<b>CHILD DEVELOPMENT CE - ALL DEPARTMENTS</b>			<b>\$4,250.00</b>

## CITY OF CASPER

CITY OF CASPER	Balefill - Disposal & Landfill	Street Sweeping	\$2,266.00
<i>CITY OF CASPER - Total For Balefill - Disposal &amp; Landfill</i>			\$2,266.00
CITY OF CASPER	CATC - CARES Act	Dec 2020 Workorder charge	\$5,858.42
CITY OF CASPER	CATC - CARES Act	Dec 2020 Fuel Charge	\$9,625.52
<i>CITY OF CASPER - Total For CATC - CARES Act</i>			\$15,483.94
CITY OF CASPER	Hogadon - Operations	Services	\$20.40
CITY OF CASPER	Hogadon - Operations	Services	\$18.00
CITY OF CASPER	Hogadon - Operations	Services	\$18.00
CITY OF CASPER	Hogadon - Operations	Services	\$20.14
CITY OF CASPER	Hogadon - Operations	Services	\$18.00
CITY OF CASPER	Hogadon - Operations	Services	\$18.00
<i>CITY OF CASPER - Total For Hogadon - Operations</i>			\$112.54
CITY OF CASPER	Metropolitan Planning Org	January 2020 Monthly GIS Services	\$6,641.05
<i>CITY OF CASPER - Total For Metropolitan Planning Org</i>			\$6,641.05
CITY OF CASPER	Refuse - Residential	Services	\$5,726.08
CITY OF CASPER	Refuse - Residential	Services	\$5,867.06
CITY OF CASPER	Refuse - Residential	Service	\$5,160.57
CITY OF CASPER	Refuse - Residential	Services	\$6,135.77
CITY OF CASPER	Refuse - Residential	Services	\$5,188.74

CITY OF CASPER	Refuse - Residential	Services	\$5,212.50
CITY OF CASPER	Refuse - Residential	Services	\$5,864.45
CITY OF CASPER	Refuse - Residential	Services	\$5,210.82
CITY OF CASPER	Refuse - Residential	Services	\$5,919.00
CITY OF CASPER	Refuse - Residential	Services	\$5,637.61
CITY OF CASPER	Refuse - Residential	Services	\$5,330.67
CITY OF CASPER	Refuse - Residential	Services	\$4,655.58
CITY OF CASPER	Refuse - Residential	Services	\$324.36
CITY OF CASPER	Refuse - Residential	Services	\$5,462.40
CITY OF CASPER	Refuse - Residential	Services	\$5,281.20
CITY OF CASPER	Refuse - Residential	Services	\$5,855.46
CITY OF CASPER	Refuse - Residential	Services	\$6,305.39
CITY OF CASPER	Refuse - Residential	Services	\$5,862.60
CITY OF CASPER	Refuse - Residential	Services	\$5,823.09
CITY OF CASPER	Refuse - Residential	Services	\$5,739.88
CITY OF CASPER	Refuse - Residential	Services	\$5,152.11
CITY OF CASPER	Refuse - Residential	Services	\$5,436.68
CITY OF CASPER	Refuse - Residential	Services	\$6,001.70
<i>CITY OF CASPER - Total For Refuse - Residential</i>			<i>\$123,153.72</i>
CITY OF CASPER	Regional Water Operations	Services	\$124.50
CITY OF CASPER	Regional Water Operations	Acti-Flo sludge to the landfill	\$5,025.24
CITY OF CASPER	Regional Water Operations	Actiflo sludge taken to the landfill	\$3,700.62
CITY OF CASPER	Regional Water Operations	Services	\$24.56
<i>CITY OF CASPER - Total For Regional Water Operations</i>			<i>\$8,874.92</i>
CITY OF CASPER	Sewer Administration	201 Sewer	359,541.90
<i>CITY OF CASPER - Total For Sewer Administration</i>			<i>\$359,541.90</i>
CITY OF CASPER	WWTP Operations	Services	\$129.32
CITY OF CASPER	WWTP Operations	Services	\$87.98
CITY OF CASPER	WWTP Operations	Services	\$86.92
CITY OF CASPER	WWTP Operations	Services	\$152.64
CITY OF CASPER	WWTP Operations	Services	\$101.76
CITY OF CASPER	WWTP Operations	Services	\$120.36
CITY OF CASPER	WWTP Operations	Services	\$49.47
CITY OF CASPER	WWTP Operations	Services	\$182.07
<i>CITY OF CASPER - Total For WWTP Operations</i>			<i>\$910.52</i>

**CITY OF CASPER - ALL DEPARTMENTS**

\$516,984.59

**CLH ASSOCIATES LLC**

CLH ASSOCIATES LLC	Metropolitan Planning Org	BAR NUNN SALT CREEK HIGHWAY CO	\$13,608.80
--------------------	---------------------------	--------------------------------	-------------

<i>CLH ASSOCIATES LLC - Total For Metropolitan Planning Org</i>			\$13,608.80
---	--	--	-------------

**CLH ASSOCIATES LLC - ALL DEPARTMENTS**

\$13,608.80

**CMI TECO, INC.**

CMI TECO, INC.	Balefill - Diversion & Special	Repairs Unit 141405	\$3,937.83
----------------	--------------------------------	---------------------	------------

<i>CMI TECO, INC. - Total For Balefill - Diversion &amp; Special</i>			\$3,937.83
--	--	--	------------

CMI TECO, INC.	Refuse - Commercial	Repairs unit 222257	\$323.31
----------------	---------------------	---------------------	----------

<i>CMI TECO, INC. - Total For Refuse - Commercial</i>			\$323.31
---	--	--	----------

CMI TECO, INC.	Refuse - Residential	Repairs to unit 222271	\$3,445.73
----------------	----------------------	------------------------	------------

CMI TECO, INC.	Refuse - Residential	Repairs unit 222262	\$4,387.53
----------------	----------------------	---------------------	------------

<i>CMI TECO, INC. - Total For Refuse - Residential</i>			\$7,833.26
--	--	--	------------

**CMI TECO, INC. - ALL DEPARTMENTS**

\$12,094.40

**COASTAL CHEMICAL CO**

COASTAL CHEMICAL CO	Regional Water Operations	Vehicle Fuel	\$68.00
---------------------	---------------------------	--------------	---------

<i>COASTAL CHEMICAL CO - Total For Regional Water Operations</i>			\$68.00
--	--	--	---------

**COASTAL CHEMICAL CO - ALL DEPARTMENTS**

\$68.00

**COCA COLA BOTTLING C**

COCA COLA BOTTLING C	Balefill - Disposal & Landfill	WATER FOR SCALE HOUSE CUSTOMERS	\$7.75
----------------------	--------------------------------	---------------------------------	--------

<i>COCA COLA BOTTLING C - Total For Balefill - Disposal &amp; Landfill</i>			\$7.75
--	--	--	--------

COCA COLA BOTTLING C	Metro Animal Shelter	water and equip rent	\$46.00
----------------------	----------------------	----------------------	---------

<i>COCA COLA BOTTLING C - Total For Metro Animal Shelter</i>			\$46.00
--	--	--	---------

**COCA COLA BOTTLING C - ALL DEPARTMENTS**

\$53.75

**COMMUNICATION TECHNO**

COMMUNICATION TECHNO	Fleet Maintenance Fund	Services	\$65.53
----------------------	------------------------	----------	---------

COMMUNICATION TECHNO	Fleet Maintenance Fund	Services	\$321.08
----------------------	------------------------	----------	----------

COMMUNICATION TECHNO	Fleet Maintenance Fund	Services	\$402.73
COMMUNICATION TECHNO	Fleet Maintenance Fund	Services	\$580.08
COMMUNICATION TECHNO	Fleet Maintenance Fund	Services	\$431.00
COMMUNICATION TECHNO	Fleet Maintenance Fund	Services	\$331.77
<i>COMMUNICATION TECHNO - Total For Fleet Maintenance Fund</i>			<i>\$2,132.19</i>
COMMUNICATION TECHNO	Police Career Services	Helmets & all the extras	\$3,444.00
<i>COMMUNICATION TECHNO - Total For Police Career Services</i>			<i>\$3,444.00</i>
<b>COMMUNICATION TECHNO - ALL DEPARTMENTS</b>			<b>\$5,576.19</b>

## COMPLETE SAFETY

COMPLETE SAFETY	Risk Management	OSHA Awareness Class	\$1,650.00
<i>COMPLETE SAFETY - Total For Risk Management</i>			<i>\$1,650.00</i>
<b>COMPLETE SAFETY - ALL DEPARTMENTS</b>			<b>\$1,650.00</b>

## COMPRESSION LEASING

COMPRESSION LEASING	Balefill - Disposal & Landfill	Repairs	\$262.50
<i>COMPRESSION LEASING - Total For Balefill - Disposal &amp; Landfill</i>			<i>\$262.50</i>
<b>COMPRESSION LEASING - ALL DEPARTMENTS</b>			<b>\$262.50</b>

## COMTRONIX, INC.

COMTRONIX, INC.	Fire-EMS Administration	November alarm monitoring all stations	\$915.00
<i>COMTRONIX, INC. - Total For Fire-EMS Administration</i>			<i>\$915.00</i>
<b>COMTRONIX, INC. - ALL DEPARTMENTS</b>			<b>\$915.00</b>

## CONSOLIDATED ELECTRI

CONSOLIDATED ELECTRI	Balefill - Disposal & Landfill	Parts for leachate	\$286.37
CONSOLIDATED ELECTRI	Balefill - Disposal & Landfill	Supplies	\$80.00
<i>CONSOLIDATED ELECTRI - Total For Balefill - Disposal &amp; Landfill</i>			<i>\$366.37</i>
<b>CONSOLIDATED ELECTRI - ALL DEPARTMENTS</b>			<b>\$366.37</b>

## CONVERGEONE

CONVERGEONE	Police Administration	Purchase phone for Det. Cole	\$327.43
-------------	-----------------------	------------------------------	----------

<i>CONVERGEONE - Total For Police Administration</i>			<i>\$327.43</i>
CONVERGEONE	Public Safety Communication	Protection agreement	\$1,360.21
<i>CONVERGEONE - Total For Public Safety Communications</i>			<i>\$1,360.21</i>
<b>CONVERGEONE - ALL DEPARTMENTS</b>			<b>\$1,687.64</b>

## Core & Main

Core & Main	Water Meters	Water meters & Registers	\$3,989.20
Core & Main	Water Meters	Water meters & Registers	\$4,117.70
<i>Core &amp; Main - Total For Water Meters</i>			<i>\$8,106.90</i>
<b>Core &amp; Main - ALL DEPARTMENTS</b>			<b>\$8,106.90</b>

## COWBOY SUPPLY HOUSE

COWBOY SUPPLY HOUSE	Buildings & Structures Fund	Supplies	\$276.12
<i>COWBOY SUPPLY HOUSE - Total For Buildings &amp; Structures Fund</i>			<i>\$276.12</i>
<b>COWBOY SUPPLY HOUSE - ALL DEPARTMENTS</b>			<b>\$276.12</b>

## CPU IIT

CPU IIT	Balefill - Baler Processing	Replacement diagnostic laptop for balers SWM1	\$987.00
<i>CPU IIT - Total For Balefill - Baler Processing</i>			<i>\$987.00</i>
CPU IIT	City Clerk	ELECTRONIC SALES	\$140.00
<i>CPU IIT - Total For City Clerk</i>			<i>\$140.00</i>
CPU IIT	Customer Service	HP LaserJet M553x Laser Printer - Color	\$499.50
<i>CPU IIT - Total For Customer Service</i>			<i>\$499.50</i>
CPU IIT	Finance	Printer Repair-Parts and Labor	\$468.33
<i>CPU IIT - Total For Finance</i>			<i>\$468.33</i>
CPU IIT	Fire-EMS Administration	Technology Items (computers, software, and ne	\$1,193.00
<i>CPU IIT - Total For Fire-EMS Administration</i>			<i>\$1,193.00</i>
CPU IIT	Human Resources	HP LaserJet M553x Laser Printer - Color	\$499.50
<i>CPU IIT - Total For Human Resources</i>			<i>\$499.50</i>
CPU IIT	Risk Management	Wireless mouse for Greeter computer	\$11.00
<i>CPU IIT - Total For Risk Management</i>			<i>\$11.00</i>
<b>CPU IIT - ALL DEPARTMENTS</b>			<b>\$3,798.33</b>

## CRESCENT ELECTRIC SU

CRESCENT ELECTRIC SU	Balefill - Baler Processing	SQD TRANSFORMER CONTROL	\$1,210.33
<i>CRESCENT ELECTRIC SU - Total For Balefill - Baler Processing</i>			<i>\$1,210.33</i>
CRESCENT ELECTRIC SU	Buildings & Structures Fund	Supplies for Golf Course Pro Shop Remodel	\$31.40
CRESCENT ELECTRIC SU	Buildings & Structures Fund	BAS Shop Tools	\$5.76
<i>CRESCENT ELECTRIC SU - Total For Buildings &amp; Structures Fund</i>			<i>\$37.16</i>
CRESCENT ELECTRIC SU	Capital Projects Fund	HVAC Repair Supplies for the Nic	\$277.79
<i>CRESCENT ELECTRIC SU - Total For Capital Projects Fund</i>			<i>\$277.79</i>
<b>CRESCENT ELECTRIC SU - ALL DEPARTMENTS</b>			<b>\$1,525.28</b>

## CROWN CONSTRUCTION L

CROWN CONSTRUCTION L	Capital Projects Fund	Station 6 Concrete	\$3,990.00
<i>CROWN CONSTRUCTION L - Total For Capital Projects Fund</i>			<i>\$3,990.00</i>
<b>CROWN CONSTRUCTION L - ALL DEPARTMENTS</b>			<b>\$3,990.00</b>

## CRUM ELECTRIC SUPPLY

CRUM ELECTRIC SUPPLY	Buildings & Structures Fund	Lighting repair parts for Water Distribution	\$14.05
CRUM ELECTRIC SUPPLY	Buildings & Structures Fund	Supplies to install bottle filler at Golf Course	\$33.13
CRUM ELECTRIC SUPPLY	Buildings & Structures Fund	Light bulbs for Fire Station 1	\$180.00
<i>CRUM ELECTRIC SUPPLY - Total For Buildings &amp; Structures Fund</i>			<i>\$227.18</i>
CRUM ELECTRIC SUPPLY	WWTP Operations	Terminations	\$49.23
<i>CRUM ELECTRIC SUPPLY - Total For WWTP Operations</i>			<i>\$49.23</i>
<b>CRUM ELECTRIC SUPPLY - ALL DEPARTMENTS</b>			<b>\$276.41</b>

## CS CONSULTING

CS CONSULTING	Balefill - Disposal & Landfill	Basic Hazard Assessment	\$785.00
<i>CS CONSULTING - Total For Balefill - Disposal &amp; Landfill</i>			<i>\$785.00</i>
<b>CS CONSULTING - ALL DEPARTMENTS</b>			<b>\$785.00</b>

## DANA KEPNER CO.

DANA KEPNER CO.	Regional Water Operations	Tap Saddle for 2200 Salt Creek Hwy	\$130.00
DANA KEPNER CO.	Regional Water Operations	Credit on return from invoice 2231885-00	(\$129.51)

DANA KEPNER CO. - Total For Regional Water Operations \$0.49

**DANA KEPNER CO. - ALL DEPARTMENTS \$0.49**

### DECKER AUTO GLASS, I

DECKER AUTO GLASS, I Fleet Maintenance Fund Windshield \$267.12

*DECKER AUTO GLASS, I - Total For Fleet Maintenance Fund \$267.12*

DECKER AUTO GLASS, I Refuse - Residential REPAIR WINDSHIELD ON SIDE LOADER \$201.39

*DECKER AUTO GLASS, I - Total For Refuse - Residential \$201.39*

**DECKER AUTO GLASS, I - ALL DEPARTMENTS \$468.51**

### DENNIS SUPPLY CO.

DENNIS SUPPLY CO. Buildings & Structures Fund Supplies \$50.51

DENNIS SUPPLY CO. Buildings & Structures Fund Supplies \$1,756.37

DENNIS SUPPLY CO. Buildings & Structures Fund BAS Shop Tools \$6.12

DENNIS SUPPLY CO. Buildings & Structures Fund Supplies \$12.50

DENNIS SUPPLY CO. Buildings & Structures Fund Supplies \$464.10

*DENNIS SUPPLY CO. - Total For Buildings & Structures Fund \$2,289.60*

**DENNIS SUPPLY CO. - ALL DEPARTMENTS \$2,289.60**

### DENVER INDUSTRIAL SA

DENVER INDUSTRIAL SA Streets 1 pallet---56 Bags UPM HP Cold Mix Patch \$838.66

*DENVER INDUSTRIAL SA - Total For Streets \$838.66*

**DENVER INDUSTRIAL SA - ALL DEPARTMENTS \$838.66**

### DEWITT WATER SYSTEMS

DEWITT WATER SYSTEMS Fire-EMS Operations Service calls at Station 3 and 6 \$70.00

*DEWITT WATER SYSTEMS - Total For Fire-EMS Operations \$70.00*

**DEWITT WATER SYSTEMS - ALL DEPARTMENTS \$70.00**

### DIAMOND VOGEL PAINTS

DIAMOND VOGEL PAINTS Buildings & Structures Fund Paint supplies \$37.22

DIAMOND VOGEL PAINTS Buildings & Structures Fund Paint supplies \$21.26

<i>DIAMOND VOGEL PAINTS - Total For Buildings &amp; Structures Fund</i>			\$58.48
<b>DIAMOND VOGEL PAINTS - ALL DEPARTMENTS</b>			<b>\$58.48</b>

## DOMINO'S 6042

DOMINO'S 6042	Police Investigations	food during srt callout	\$130.02
<i>DOMINO'S 6042 - Total For Police Investigations</i>			<i>\$130.02</i>
<b>DOMINO'S 6042 - ALL DEPARTMENTS</b>			<b>\$130.02</b>

## DOORWAYS OF WYOMING

DOORWAYS OF WYOMING	Buildings & Structures Fund	Door repair supplies for Fire Station 6	\$245.50
<i>DOORWAYS OF WYOMING - Total For Buildings &amp; Structures Fund</i>			<i>\$245.50</i>
<b>DOORWAYS OF WYOMING - ALL DEPARTMENTS</b>			<b>\$245.50</b>

## DPC INDUSTRIES, INC.

DPC INDUSTRIES, INC.	Regional Water Operations	Sodium Hypohlorite 12/18/20	\$6,886.27
<i>DPC INDUSTRIES, INC. - Total For Regional Water Operations</i>			<i>\$6,886.27</i>
<b>DPC INDUSTRIES, INC. - ALL DEPARTMENTS</b>			<b>\$6,886.27</b>

## EAK INC

EAK INC	City Council	Services	\$500.00
<i>EAK INC - Total For City Council</i>			<i>\$500.00</i>
<b>EAK INC - ALL DEPARTMENTS</b>			<b>\$500.00</b>

## EATON SALES & SVC.,

EATON SALES & SVC.,	Fleet Maintenance Fund	Services	\$1,130.96
<i>EATON SALES &amp; SVC., - Total For Fleet Maintenance Fund</i>			<i>\$1,130.96</i>
<b>EATON SALES &amp; SVC., - ALL DEPARTMENTS</b>			<b>\$1,130.96</b>

## ECONOMIC DEVELOPMENT

ECONOMIC DEVELOPMENT	Social Community Services	Grant Assistance - Sustainable	\$1,666.68
ECONOMIC DEVELOPMENT	Social Community Services	Funding	\$86,603.25



ECONOMIC DEVELOPMENT	Social Community Services	Grant Assistance - Sustainable	\$4,166.66
<i>ECONOMIC DEVELOPMENT - Total For Social Community Services</i>			<i>\$92,436.59</i>
<b>ECONOMIC DEVELOPMENT - ALL DEPARTMENTS</b>			<b>\$92,436.59</b>

## EDGE ENGINEERING GRO

EDGE ENGINEERING GRO	Balefill - Disposal & Landfill	Methane Detector Calibration	\$1,200.00
EDGE ENGINEERING GRO	Balefill - Disposal & Landfill	Methane Sampling Ports	\$347.78
EDGE ENGINEERING GRO	Balefill - Disposal & Landfill	Monitoring & Sampling	\$513.18
EDGE ENGINEERING GRO	Balefill - Disposal & Landfill	Methane Sampling Ports	\$463.71
EDGE ENGINEERING GRO	Balefill - Disposal & Landfill	Annual monitoring & sampling	\$288.66
<i>EDGE ENGINEERING GRO - Total For Balefill - Disposal &amp; Landfill</i>			<i>\$2,813.33</i>
<b>EDGE ENGINEERING GRO - ALL DEPARTMENTS</b>			<b>\$2,813.33</b>

## ELDEAN INC

ELDEAN INC	Buildings & Structures Fund	Install new Burnham Boilers	\$34,495.00
ELDEAN INC	Buildings & Structures Fund	Installation	\$1,200.00
<i>ELDEAN INC - Total For Buildings &amp; Structures Fund</i>			<i>\$35,695.00</i>
<b>ELDEAN INC - ALL DEPARTMENTS</b>			<b>\$35,695.00</b>

## EMPLOYEE REIMBURSEME

EMPLOYEE REIMBURSEME	Balefill - Disposal & Landfill	Winter Clothing reimbursement	\$83.99
<i>EMPLOYEE REIMBURSEME - Total For Balefill - Disposal &amp; Landfill</i>			<i>\$83.99</i>
EMPLOYEE REIMBURSEME	Buildings & Structures Fund	Boot Reimbursement	\$150.00
EMPLOYEE REIMBURSEME	Buildings & Structures Fund	Clothing Allowance	\$97.61
EMPLOYEE REIMBURSEME	Buildings & Structures Fund	Clothing Reimbursement	\$100.00
<i>EMPLOYEE REIMBURSEME - Total For Buildings &amp; Structures Fund</i>			<i>\$347.61</i>
EMPLOYEE REIMBURSEME	Cemetery	Clothing/Boot reimbursement	\$250.00
<i>EMPLOYEE REIMBURSEME - Total For Cemetery</i>			<i>\$250.00</i>
EMPLOYEE REIMBURSEME	Fleet Maintenance Fund	Tool Reimbursement	\$115.49
<i>EMPLOYEE REIMBURSEME - Total For Fleet Maintenance Fund</i>			<i>\$115.49</i>
EMPLOYEE REIMBURSEME	Police Administration	Clothing reimbursement	\$245.67
<i>EMPLOYEE REIMBURSEME - Total For Police Administration</i>			<i>\$245.67</i>
EMPLOYEE REIMBURSEME	Refuse - Commercial	Boot reimbursement	\$150.00

<i>EMPLOYEE REIMBURSEME - Total For Refuse - Commercial</i>			\$150.00
EMPLOYEE REIMBURSEME	Water Distribution	Clothing Reimbursement	\$98.00
<i>EMPLOYEE REIMBURSEME - Total For Water Distribution</i>			\$98.00
EMPLOYEE REIMBURSEME	Water Meters	DEQ Dist System reimbursement	\$100.00
<i>EMPLOYEE REIMBURSEME - Total For Water Meters</i>			\$100.00
<b>EMPLOYEE REIMBURSEME - ALL DEPARTMENTS</b>			<b>\$1,390.76</b>

## ENERGY LABORATORIES

ENERGY LABORATORIES	Fire-EMS Operations	Natural Gas Analysis	\$204.00
<i>ENERGY LABORATORIES - Total For Fire-EMS Operations</i>			\$204.00
ENERGY LABORATORIES	Regional Water Operations	Credit for overcharge on invoice 366454	(\$75.00)
ENERGY LABORATORIES	Regional Water Operations	Lab Test TAS	\$306.00
ENERGY LABORATORIES	Regional Water Operations	Lab Test BCT	\$22.00
ENERGY LABORATORIES	Regional Water Operations	Lab Test TAS	\$306.00
ENERGY LABORATORIES	Regional Water Operations	Lab Test Well Mix	\$57.00
ENERGY LABORATORIES	Regional Water Operations	Lab Test TAS	\$231.00
<i>ENERGY LABORATORIES - Total For Regional Water Operations</i>			\$847.00
<b>ENERGY LABORATORIES - ALL DEPARTMENTS</b>			<b>\$1,051.00</b>

## ENERGY LABRATORIES I

ENERGY LABRATORIES I	Water Tanks	Testing	\$660.00
ENERGY LABRATORIES I	Water Tanks	Testing	\$374.00
ENERGY LABRATORIES I	Water Tanks	Testing	\$321.50
ENERGY LABRATORIES I	Water Tanks	Testing	\$140.00
<i>ENERGY LABRATORIES I - Total For Water Tanks</i>			\$1,495.50
<b>ENERGY LABRATORIES I - ALL DEPARTMENTS</b>			<b>\$1,495.50</b>

## EXXONMOBIL

EXXONMOBIL	Fire-EMS Operations	Fuel	\$6.22
EXXONMOBIL	Fire-EMS Operations	Good 2 Go - Fuel	\$33.38
EXXONMOBIL	Fire-EMS Operations	Good 2 Go - Fuel	\$33.50
EXXONMOBIL	Fire-EMS Operations	Good 2 Go - Fuel	\$20.17
EXXONMOBIL	Fire-EMS Operations	Good 2 Go - Fuel	\$12.47

EXXONMOBIL	Fire-EMS Operations	Good 2 Go - Fuel	\$34.44
<i>EXXONMOBIL - Total For Fire-EMS Operations</i>			<i>\$140.18</i>
<b>EXXONMOBIL - ALL DEPARTMENTS</b>			<b>\$140.18</b>

## FACEBK 8GBE7ZWXJ2

FACEBK 8GBE7ZWXJ2	Police Administration	recruitment ad	\$100.00
<i>FACEBK 8GBE7ZWXJ2 - Total For Police Administration</i>			<i>\$100.00</i>
<b>FACEBK 8GBE7ZWXJ2 - ALL DEPARTMENTS</b>			<b>\$100.00</b>

## FACEBK GUGA8ZJXJ2

FACEBK GUGA8ZJXJ2	Police Administration	recruitment ad	\$87.42
<i>FACEBK GUGA8ZJXJ2 - Total For Police Administration</i>			<i>\$87.42</i>
<b>FACEBK GUGA8ZJXJ2 - ALL DEPARTMENTS</b>			<b>\$87.42</b>

## FARMER BROTHERS CO

FARMER BROTHERS CO	Balefill - Disposal & Landfill	Supplies	\$118.02
<i>FARMER BROTHERS CO - Total For Balefill - Disposal &amp; Landfill</i>			<i>\$118.02</i>
<b>FARMER BROTHERS CO - ALL DEPARTMENTS</b>			<b>\$118.02</b>

## FEDEX OFFIC942000094

FEDEX OFFIC942000094	Police Administration	shop with a cop paperwork	\$74.37
<i>FEDEX OFFIC942000094 - Total For Police Administration</i>			<i>\$74.37</i>
<b>FEDEX OFFIC942000094 - ALL DEPARTMENTS</b>			<b>\$74.37</b>

## FERGUSON ENTERPRISES

FERGUSON ENTERPRISES	Ft. Caspar Museum	Supplies to replace drinking fountain with bottle	\$25.45
<i>FERGUSON ENTERPRISES - Total For Ft. Caspar Museum</i>			<i>\$25.45</i>
FERGUSON ENTERPRISES	WWTP Operations	PLUMBING Parts	\$17.17
FERGUSON ENTERPRISES	WWTP Operations	PLUMBING Parts	\$86.30
<i>FERGUSON ENTERPRISES - Total For WWTP Operations</i>			<i>\$103.47</i>
<b>FERGUSON ENTERPRISES - ALL DEPARTMENTS</b>			<b>\$128.92</b>

## FIRE END & CROKER CO

FIRE END & CROKER CO	Fire-EMS Operations	Uniform shirts and pants	\$1,879.92
<i>FIRE END &amp; CROKER CO - Total For Fire-EMS Operations</i>			<i>\$1,879.92</i>
<b>FIRE END &amp; CROKER CO - ALL DEPARTMENTS</b>			<b>\$1,879.92</b>

## FIRE PROTECTION PUB

FIRE PROTECTION PUB	Fire-EMS Training	Books for training division	\$225.00
<i>FIRE PROTECTION PUB - Total For Fire-EMS Training</i>			<i>\$225.00</i>
<b>FIRE PROTECTION PUB - ALL DEPARTMENTS</b>			<b>\$225.00</b>

## FIREROCK STEAKHOUSE

FIREROCK STEAKHOUSE	Human Resources	3, \$50 gift cards for gift card giveaway Fire Rock	\$150.00
<i>FIREROCK STEAKHOUSE - Total For Human Resources</i>			<i>\$150.00</i>
<b>FIREROCK STEAKHOUSE - ALL DEPARTMENTS</b>			<b>\$150.00</b>

## FIRST DATA MERCHANT

FIRST DATA MERCHANT	Cemetery	November 2020	\$19.95
<i>FIRST DATA MERCHANT - Total For Cemetery</i>			<i>\$19.95</i>
<b>FIRST DATA MERCHANT - ALL DEPARTMENTS</b>			<b>\$19.95</b>

## FIRST INTERSTATE BAN

FIRST INTERSTATE BAN	Human Resources	Gift Cards	\$91.00
<i>FIRST INTERSTATE BAN - Total For Human Resources</i>			<i>\$91.00</i>
<b>FIRST INTERSTATE BAN - ALL DEPARTMENTS</b>			<b>\$91.00</b>

## FIVE TRAILS ROTARY C

FIVE TRAILS ROTARY C	City Clerk	Tremel Dues	\$650.00
<i>FIVE TRAILS ROTARY C - Total For City Clerk</i>			<i>\$650.00</i>
<b>FIVE TRAILS ROTARY C - ALL DEPARTMENTS</b>			<b>\$650.00</b>

## FLANNIGAN'S FURNITUR

FLANNIGAN'S FURNITUR	Fire-EMS Operations	Replacement Mattresses for Stations 1, 3 & 6	\$13,620.00
<i>FLANNIGAN'S FURNITUR - Total For Fire-EMS Operations</i>			<i>\$13,620.00</i>
<b>FLANNIGAN'S FURNITUR - ALL DEPARTMENTS</b>			<b>\$13,620.00</b>

## FOREMANS QUALITY MAC

FOREMANS QUALITY MAC	WWTP Operations	Grit hopper opener	\$705.22
<i>FOREMANS QUALITY MAC - Total For WWTP Operations</i>			<i>\$705.22</i>
<b>FOREMANS QUALITY MAC - ALL DEPARTMENTS</b>			<b>\$705.22</b>

## FORMS FULFILLMENT CE

FORMS FULFILLMENT CE	Finance	Tyler Check Stock for Printing Checks	\$288.10
<i>FORMS FULFILLMENT CE - Total For Finance</i>			<i>\$288.10</i>
<b>FORMS FULFILLMENT CE - ALL DEPARTMENTS</b>			<b>\$288.10</b>

## GALLS, INC.

GALLS, INC.	Police Career Services	Uniforms	\$58.50
<i>GALLS, INC. - Total For Police Career Services</i>			<i>\$58.50</i>
<b>GALLS, INC. - ALL DEPARTMENTS</b>			<b>\$58.50</b>

## GAYLORD BROS INC

GAYLORD BROS INC	Ft. Caspar Museum	Archive and Collection Boxes	\$278.67
<i>GAYLORD BROS INC - Total For Ft. Caspar Museum</i>			<i>\$278.67</i>
<b>GAYLORD BROS INC - ALL DEPARTMENTS</b>			<b>\$278.67</b>

## G-C BUILDING SUPPLY

G-C BUILDING SUPPLY	Refuse - Commercial	Repairs	\$505.00
<i>G-C BUILDING SUPPLY - Total For Refuse - Commercial</i>			<i>\$505.00</i>
<b>G-C BUILDING SUPPLY - ALL DEPARTMENTS</b>			<b>\$505.00</b>

## GEOSYNTEC CONSULTANT

GEOSYNTEC CONSULTANT	Balefill - Disposal & Landfill	Gems S028998-CRL Monitoring &	\$860.45
<i>GEOSYNTEC CONSULTANT - Total For Balefill - Disposal &amp; Landfill</i>			<i>\$860.45</i>
<b>GEOSYNTEC CONSULTANT - ALL DEPARTMENTS</b>			<b>\$860.45</b>

## GLOBAL SPECTRUM L.P.

GLOBAL SPECTRUM L.P.	Casper Events Center Fund	Net Loss Funds February 2021	\$82,909.91
<i>GLOBAL SPECTRUM L.P. - Total For Casper Events Center Fund</i>			<i>\$82,909.91</i>
<b>GLOBAL SPECTRUM L.P. - ALL DEPARTMENTS</b>			<b>\$82,909.91</b>

## GOLDER ASSOCIATES

GOLDER ASSOCIATES	Balefill - Disposal & Landfill	SW Monitoring Ntwrk Upgrds & C	\$412.50
GOLDER ASSOCIATES	Balefill - Disposal & Landfill	NMOC Tier II Emissions Testing	\$401.10
GOLDER ASSOCIATES	Balefill - Disposal & Landfill	Gems S028759-5-Year Air Emissi	\$786.25
<i>GOLDER ASSOCIATES - Total For Balefill - Disposal &amp; Landfill</i>			<i>\$1,599.85</i>
GOLDER ASSOCIATES	Capital Projects Fund	Contamination monitoring for 1	\$1,827.00
<i>GOLDER ASSOCIATES - Total For Capital Projects Fund</i>			<i>\$1,827.00</i>
<b>GOLDER ASSOCIATES - ALL DEPARTMENTS</b>			<b>\$3,426.85</b>

## GRAINGER, INC.

GRAINGER, INC.	Buildings & Structures Fund	Batteries for BAS shop work	\$11.22
GRAINGER, INC.	Buildings & Structures Fund	Fuses	\$27.80
<i>GRAINGER, INC. - Total For Buildings &amp; Structures Fund</i>			<i>\$39.02</i>
<b>GRAINGER, INC. - ALL DEPARTMENTS</b>			<b>\$39.02</b>

## GREEN'S SEWER & DRAI

GREEN'S SEWER & DRAI	Buildings & Structures Fund	Work at CIA	\$150.00
<i>GREEN'S SEWER &amp; DRAI - Total For Buildings &amp; Structures Fund</i>			<i>\$150.00</i>
<b>GREEN'S SEWER &amp; DRAI - ALL DEPARTMENTS</b>			<b>\$150.00</b>

## GW MECHANICAL, INC.

GW MECHANICAL, INC.	Regional Water Operations	Replace hot water supply pump in the mechanic	\$5,600.00
<i>GW MECHANICAL, INC. - Total For Regional Water Operations</i>			<i>\$5,600.00</i>
<b>GW MECHANICAL, INC. - ALL DEPARTMENTS</b>			<b>\$5,600.00</b>

## HARBOR FREIGHT TOOLS

HARBOR FREIGHT TOOLS	Refuse - Residential	TAP AND DIE SET FOR TRUCK BARN	\$43.98
<i>HARBOR FREIGHT TOOLS - Total For Refuse - Residential</i>			<i>\$43.98</i>
HARBOR FREIGHT TOOLS	Regional Water Operations	Lab supplies	\$44.97
<i>HARBOR FREIGHT TOOLS - Total For Regional Water Operations</i>			<i>\$44.97</i>
<b>HARBOR FREIGHT TOOLS - ALL DEPARTMENTS</b>			<b>\$88.95</b>

## HDR ENGINEERING, INC

HDR ENGINEERING, INC	Water Tanks	Water Rights Supply Studies 20	\$1,552.50
<i>HDR ENGINEERING, INC - Total For Water Tanks</i>			<i>\$1,552.50</i>
<b>HDR ENGINEERING, INC - ALL DEPARTMENTS</b>			<b>\$1,552.50</b>

## HOMAX OIL SALES INC

HOMAX OIL SALES INC	WWTP Operations	Lubricant	\$1,341.40
<i>HOMAX OIL SALES INC - Total For WWTP Operations</i>			<i>\$1,341.40</i>
<b>HOMAX OIL SALES INC - ALL DEPARTMENTS</b>			<b>\$1,341.40</b>

## HOMAX OIL SALES, INC

HOMAX OIL SALES, INC	Balefill - Disposal & Landfill	DEF	\$642.40
<i>HOMAX OIL SALES, INC - Total For Balefill - Disposal &amp; Landfill</i>			<i>\$642.40</i>
HOMAX OIL SALES, INC	Fleet Maintenance Fund	Fuel	\$16,536.04
HOMAX OIL SALES, INC	Fleet Maintenance Fund	Fuel	\$17,177.71
<i>HOMAX OIL SALES, INC - Total For Fleet Maintenance Fund</i>			<i>\$33,713.75</i>
<b>HOMAX OIL SALES, INC - ALL DEPARTMENTS</b>			<b>\$34,356.15</b>

## IDEXX DISTRIBUTION I

IDEXX DISTRIBUTION I	Regional Water Operations	Lab supply	\$234.60
<i>IDEXX DISTRIBUTION I - Total For Regional Water Operations</i>			<i>\$234.60</i>

**IDEXX DISTRIBUTION I - ALL DEPARTMENTS** \$234.60

## **IMLSS UTAH**

IMLSS UTAH Buildings & Structures Fund Lock supplies for Customer Service at City Hall \$687.47

*IMLSS UTAH - Total For Buildings & Structures Fund* \$687.47

**IMLSS UTAH - ALL DEPARTMENTS** \$687.47

## **INBERG-MILLER ENGINE**

INBERG-MILLER ENGINE Water Distribution Testing services \$756.00

*INBERG-MILLER ENGINE - Total For Water Distribution* \$756.00

**INBERG-MILLER ENGINE - ALL DEPARTMENTS** \$756.00

## **INDUSTRIAL SCREEN &**

INDUSTRIAL SCREEN & Traffic Control Anti cut material for top of sign table \$115.00

*INDUSTRIAL SCREEN & - Total For Traffic Control* \$115.00

**INDUSTRIAL SCREEN & - ALL DEPARTMENTS** \$115.00

## **INTERNATION**

INTERNATION City Clerk CHARITABLE AND SOCIAL SERVICE ORGANIZATI \$735.00

*INTERNATION - Total For City Clerk* \$735.00

**INTERNATION - ALL DEPARTMENTS** \$735.00

## **INTUIT, INC.**

INTUIT, INC. Balefill - Baler Processing WASH WALLS AND FLOOR IN TUNNEL UNDER N \$400.00

INTUIT, INC. Balefill - Baler Processing REPAIR BALER PIT HAND RAIL \$300.00

INTUIT, INC. Balefill - Baler Processing TROUBLE SHOOT GARAGE DOOR AT BALER \$400.00

*INTUIT, INC. - Total For Balefill - Baler Processing* \$1,100.00

INTUIT, INC. City Manager Membership dues for Rotary \$68.00

*INTUIT, INC. - Total For City Manager* \$68.00

INTUIT, INC. Hogadon - Operations safety net \$124.13

*INTUIT, INC. - Total For Hogadon - Operations* \$124.13



**INTUIT, INC. - ALL DEPARTMENTS** \$1,292.13

## ISA

ISA	Weed & Pest Fund	ISA Garret Brunson Testing Fee	\$457.00
-----	------------------	--------------------------------	----------

<i>ISA - Total For Weed &amp; Pest Fund</i>			\$457.00
---	--	--	----------

**ISA - ALL DEPARTMENTS** \$457.00

## JACOBS ENGINEERING G

JACOBS ENGINEERING G	WWTP Operations	North Platte Sanitary Sewer Re	\$2,776.40
----------------------	-----------------	--------------------------------	------------

<i>JACOBS ENGINEERING G - Total For WWTP Operations</i>			\$2,776.40
---	--	--	------------

**JACOBS ENGINEERING G - ALL DEPARTMENTS** \$2,776.40

## J'S PUB & GRILL

J'S PUB & GRILL	Human Resources	3, \$50 gift cards J's Pub & Grill	\$150.00
-----------------	-----------------	------------------------------------	----------

<i>J'S PUB &amp; GRILL - Total For Human Resources</i>			\$150.00
--	--	--	----------

**J'S PUB & GRILL - ALL DEPARTMENTS** \$150.00

## KNIFE RIVER/JTL

KNIFE RIVER/JTL	Streets	Plant mix	\$120.64
-----------------	---------	-----------	----------

KNIFE RIVER/JTL	Streets	Plant mix	\$352.06
-----------------	---------	-----------	----------

<i>KNIFE RIVER/JTL - Total For Streets</i>			\$472.70
--	--	--	----------

**KNIFE RIVER/JTL - ALL DEPARTMENTS** \$472.70

## KNUCKLE DRAGGER TACT

KNUCKLE DRAGGER TACT	Police Career Services	Development & Implementation tactical course	\$3,645.00
----------------------	------------------------	--	------------

<i>KNUCKLE DRAGGER TACT - Total For Police Career Services</i>			\$3,645.00
--	--	--	------------

**KNUCKLE DRAGGER TACT - ALL DEPARTMENTS** \$3,645.00

## LISA'S SPIC N SPAN

LISA'S SPIC N SPAN	Balefill - Disposal & Landfill	Cleaning January 11 - 17, 2021	\$440.00
--------------------	--------------------------------	--------------------------------	----------

LISA'S SPIC N SPAN	Balefill - Disposal & Landfill	Cleaning services	\$395.00
--------------------	--------------------------------	-------------------	----------

LISA'S SPIC N SPAN - Total For Balefill - Disposal & Landfill \$835.00

**LISA'S SPIC N SPAN - ALL DEPARTMENTS \$835.00**

### LOAF N JUG #0106

LOAF N JUG #0106 Fire-EMS Operations Propane \$23.09

LOAF N JUG #0106 Fire-EMS Operations Fuel \$7.09

LOAF N JUG #0106 - Total For Fire-EMS Operations \$30.18

**LOAF N JUG #0106 - ALL DEPARTMENTS \$30.18**

### LUM STUDIO

LUM STUDIO Planning Services \$427.50

LUM STUDIO - Total For Planning \$427.50

**LUM STUDIO - ALL DEPARTMENTS \$427.50**

### MENARDS CASPER WY

MENARDS CASPER WY Buildings & Structures Fund Supplies to build new counter for Golf Course Pr \$207.69

MENARDS CASPER WY - Total For Buildings & Structures Fund \$207.69

MENARDS CASPER WY Cemetery HOME SUPPLY WAREHOUSE STORES locate nails \$35.92

MENARDS CASPER WY - Total For Cemetery \$35.92

MENARDS CASPER WY Parks - Parks Maint. Supplies for Eagle Scout project - Dallason Shelt \$994.06

MENARDS CASPER WY - Total For Parks - Parks Maint. \$994.06

MENARDS CASPER WY Refuse - Residential TOOLS \$547.68

MENARDS CASPER WY - Total For Refuse - Residential \$547.68

MENARDS CASPER WY Traffic Control Paper towels and stool replacement for Traffic s \$65.93

MENARDS CASPER WY Traffic Control Electrical connectors for signal repairs \$4.76

MENARDS CASPER WY Traffic Control Replacement LED light bulbs for Traffic shop fro \$63.92

MENARDS CASPER WY - Total For Traffic Control \$134.61

MENARDS CASPER WY Water Tanks CY TANK & BOOSTER SAMPLE PORTS \$88.68

MENARDS CASPER WY - Total For Water Tanks \$88.68

**MENARDS CASPER WY - ALL DEPARTMENTS \$2,008.64**

### MERBACK AWARDS COMPA

MERBACK AWARDS COMPA City Council Council plaques \$850.68

MERBACK AWARDS COMPA	City Council	Council name tags	\$102.60
<i>MERBACK AWARDS COMPA - Total For City Council</i>			<i>\$953.28</i>
MERBACK AWARDS COMPA	Fire-EMS Administration	Picture frame for Fire Chief	\$23.76
<i>MERBACK AWARDS COMPA - Total For Fire-EMS Administration</i>			<i>\$23.76</i>
<b>MERBACK AWARDS COMPA - ALL DEPARTMENTS</b>			<b>\$977.04</b>

## MERCER HOUSE, INC.

MERCER HOUSE, INC.	Capital Projects Fund	1%#16 Funding Mercer Family Re	\$6,401.10
<i>MERCER HOUSE, INC. - Total For Capital Projects Fund</i>			<i>\$6,401.10</i>
<b>MERCER HOUSE, INC. - ALL DEPARTMENTS</b>			<b>\$6,401.10</b>

## MICRO MOTION INC

MICRO MOTION INC	WWTP Regional Interceptors	Rosemount Magnetic Flow Meter	\$2,235.53
MICRO MOTION INC	WWTP Regional Interceptors	Rosemount Magnetic Flow Meter	\$480.00
MICRO MOTION INC	WWTP Regional Interceptors	Duplicate payment on invoice #40613789	(\$480.00)
<i>MICRO MOTION INC - Total For WWTP Regional Interceptors</i>			<i>\$2,235.53</i>
<b>MICRO MOTION INC - ALL DEPARTMENTS</b>			<b>\$2,235.53</b>

## MIDLAND SCIENTIFIC I

MIDLAND SCIENTIFIC I	WWTP Operations	Lab supplies	\$238.80
<i>MIDLAND SCIENTIFIC I - Total For WWTP Operations</i>			<i>\$238.80</i>
<b>MIDLAND SCIENTIFIC I - ALL DEPARTMENTS</b>			<b>\$238.80</b>

## MONNIT CORPORATION

MONNIT CORPORATION	Information Services	Monnit Support	\$39.00
<i>MONNIT CORPORATION - Total For Information Services</i>			<i>\$39.00</i>
<b>MONNIT CORPORATION - ALL DEPARTMENTS</b>			<b>\$39.00</b>

## Monson

Monson	Buildings & Structures Fund	Cleaning services	\$6,578.98
<i>Monson - Total For Buildings &amp; Structures Fund</i>			<i>\$6,578.98</i>
Monson	Social Community Services	Covid wipe down - City Hall	\$630.00

Monson - Total For Social Community Services \$630.00

**Monson - ALL DEPARTMENTS \$7,208.98**

## MOTOROLA SOLUTIONS

MOTOROLA SOLUTIONS Public Safety Communication Equipment at pscc \$9,457.67

*MOTOROLA SOLUTIONS - Total For Public Safety Communications \$9,457.67*

MOTOROLA SOLUTIONS Refuse - Recycling TWO WAY RADIO FOR NEW HAUL TRUCK FOR M \$3,239.00

*MOTOROLA SOLUTIONS - Total For Refuse - Recycling \$3,239.00*

**MOTOROLA SOLUTIONS - ALL DEPARTMENTS \$12,696.67**

## MOUNTAIN WEST TELEPH

MOUNTAIN WEST TELEPH Balefill - Disposal & Landfill Services \$79.90

*MOUNTAIN WEST TELEPH - Total For Balefill - Disposal & Landfill \$79.90*

MOUNTAIN WEST TELEPH Information Services Enterprise Internet Service \$1,000.00

*MOUNTAIN WEST TELEPH - Total For Information Services \$1,000.00*

**MOUNTAIN WEST TELEPH - ALL DEPARTMENTS \$1,079.90**

## MSICERTIFIED.COM

MSICERTIFIED.COM Sewer Wastewater Collection training-Matt Wilhelms \$299.95

*MSICERTIFIED.COM - Total For Sewer Wastewater Collection \$299.95*

**MSICERTIFIED.COM - ALL DEPARTMENTS \$299.95**

## MURDOCH'S RANCH&HOME

MURDOCH'S RANCH&HOM Fire-EMS Operations Stihl Moto Mix \$186.97

*MURDOCH'S RANCH&HOME - Total For Fire-EMS Operations \$186.97*

**MURDOCH'S RANCH&HOME - ALL DEPARTMENTS \$186.97**

## NAPA AUTO PARTS CORP

NAPA AUTO PARTS CORP City Council Supplies \$8,746.60

*NAPA AUTO PARTS CORP - Total For City Council \$8,746.60*

NAPA AUTO PARTS CORP Fleet Maintenance Fund Supplies \$368.84

NAPA AUTO PARTS CORP Fleet Maintenance Fund Supplies \$46.14

NAPA AUTO PARTS CORP	Fleet Maintenance Fund	Supplies	\$55,941.23
NAPA AUTO PARTS CORP	Fleet Maintenance Fund	Supplies	\$14,960.86
<i>NAPA AUTO PARTS CORP - Total For Fleet Maintenance Fund</i>			<i>\$71,317.07</i>
NAPA AUTO PARTS CORP	WWTP Operations	Lube	\$44.94
<i>NAPA AUTO PARTS CORP - Total For WWTP Operations</i>			<i>\$44.94</i>
<b>NAPA AUTO PARTS CORP - ALL DEPARTMENTS</b>			<b>\$80,108.61</b>

## NATRONA COUNTY OFFIC

NATRONA COUNTY OFFIC	Police Administration	December 20 prisoner housing	\$90,229.68
<i>NATRONA COUNTY OFFIC - Total For Police Administration</i>			<i>\$90,229.68</i>
NATRONA COUNTY OFFIC	Social Community Services	Nov 2020 Tax Revenues	\$42,750.00
NATRONA COUNTY OFFIC	Social Community Services	Tax Revenues	\$42,750.00
<i>NATRONA COUNTY OFFIC - Total For Social Community Services</i>			<i>\$85,500.00</i>
<b>NATRONA COUNTY OFFIC - ALL DEPARTMENTS</b>			<b>\$175,729.68</b>

## NICOLAYSEN ART MUSEU

NICOLAYSEN ART MUSEU	Capital Projects Fund	1% #16 Funding Nicolaysen Art	\$3,880.43
<i>NICOLAYSEN ART MUSEU - Total For Capital Projects Fund</i>			<i>\$3,880.43</i>
<b>NICOLAYSEN ART MUSEU - ALL DEPARTMENTS</b>			<b>\$3,880.43</b>

## NOLAND FEED

NOLAND FEED	Metro Animal Shelter	cat food	\$252.96
<i>NOLAND FEED - Total For Metro Animal Shelter</i>			<i>\$252.96</i>
NOLAND FEED	Police Canine Operations	canine food	\$123.15
<i>NOLAND FEED - Total For Police Canine Operations</i>			<i>\$123.15</i>
<b>NOLAND FEED - ALL DEPARTMENTS</b>			<b>\$376.11</b>

## NORCO, INC.

NORCO, INC.	Balefill - Baler Processing	Portable magnetic Drill	\$1,690.00
NORCO, INC.	Balefill - Baler Processing	Supplies	\$1,197.80
NORCO, INC.	Balefill - Baler Processing	Supplies	\$532.74
<i>NORCO, INC. - Total For Balefill - Baler Processing</i>			<i>\$3,420.54</i>
NORCO, INC.	Balefill - Disposal & Landfill	Supplies	\$45.96

<i>NORCO, INC. - Total For Balefill - Disposal &amp; Landfill</i>			<i>\$45.96</i>
NORCO, INC.	Buildings & Structures Fund	Supplies for Ice Arena Maintenance	\$238.73
NORCO, INC.	Buildings & Structures Fund	Supplies	\$429.30
NORCO, INC.	Buildings & Structures Fund	City Hall Custodial Supplies	\$429.30
NORCO, INC.	Buildings & Structures Fund	Supplies for Ice Arena Maintenance	\$23.25
<i>NORCO, INC. - Total For Buildings &amp; Structures Fund</i>			<i>\$1,120.58</i>
NORCO, INC.	Cemetery	LAB/MEDICAL/DENTAL/OPHTHALMIC HOSPITAL	\$66.44
<i>NORCO, INC. - Total For Cemetery</i>			<i>\$66.44</i>
NORCO, INC.	Fire-EMS Operations	FR Coveralls	\$150.30
NORCO, INC.	Fire-EMS Operations	Disinfectant - Station Supplies	\$64.28
<i>NORCO, INC. - Total For Fire-EMS Operations</i>			<i>\$214.58</i>
NORCO, INC.	Hogadon - Operations	Shop ox tank rental	\$6.63
NORCO, INC.	Hogadon - Operations	LAB/MEDICAL/DENTAL/OPHTHALMIC HOSPITAL	\$80.68
NORCO, INC.	Hogadon - Operations	Lodge supplies	\$218.30
<i>NORCO, INC. - Total For Hogadon - Operations</i>			<i>\$305.61</i>
NORCO, INC.	Rec Center - Operations	Custodial Cleaning Supplies	\$769.63
<i>NORCO, INC. - Total For Rec Center - Operations</i>			<i>\$769.63</i>
NORCO, INC.	Refuse - Residential	FLOOR SWEEPER for MRF	\$24,274.21
<i>NORCO, INC. - Total For Refuse - Residential</i>			<i>\$24,274.21</i>
NORCO, INC.	Regional Water Operations	Calibrate Air Monitor	\$50.00
<i>NORCO, INC. - Total For Regional Water Operations</i>			<i>\$50.00</i>
<b>NORCO, INC. - ALL DEPARTMENTS</b>			<b>\$30,267.55</b>

## NORDIC SOUND INCORPO

NORDIC SOUND INCORPO	Capital Projects Fund	Council Chambers AV Upgrades	\$7,901.25
<i>NORDIC SOUND INCORPO - Total For Capital Projects Fund</i>			<i>\$7,901.25</i>
<b>NORDIC SOUND INCORPO - ALL DEPARTMENTS</b>			<b>\$7,901.25</b>

## NORTHWEST CONTRACTOR

NORTHWEST CONTRACTOR	Balefill - Baler Processing	Supplies	\$182.52
<i>NORTHWEST CONTRACTOR - Total For Balefill - Baler Processing</i>			<i>\$182.52</i>
NORTHWEST CONTRACTOR	Balefill - Disposal & Landfill	Safety Supplies	\$799.79
NORTHWEST CONTRACTOR	Balefill - Disposal & Landfill	Supplies	\$1,999.55
<i>NORTHWEST CONTRACTOR - Total For Balefill - Disposal &amp; Landfill</i>			<i>\$2,799.34</i>

NORTHWEST CONTRACTOR	Sewer Wastewater Collection safety supplies		\$88.68
<i>NORTHWEST CONTRACTOR - Total For Sewer Wastewater Collection</i>			\$88.68
NORTHWEST CONTRACTOR	Traffic Control	Red pin flags for locates	\$29.56
<i>NORTHWEST CONTRACTOR - Total For Traffic Control</i>			\$29.56
<b>NORTHWEST CONTRACTOR - ALL DEPARTMENTS</b>			<b>\$3,100.10</b>

## OCEANID

OCEANID	Fire-EMS Operations	Inflatable Rescue Boat	\$4,900.00
<i>OCEANID - Total For Fire-EMS Operations</i>			\$4,900.00
<b>OCEANID - ALL DEPARTMENTS</b>			<b>\$4,900.00</b>

## O'REILLY AUTO PARTS

O'REILLY AUTO PARTS	Balefill - Baler Processing	BALER BLDG GLASS CLEANER AND AIR HOSE	\$83.95
<i>O'REILLY AUTO PARTS - Total For Balefill - Baler Processing</i>			\$83.95
O'REILLY AUTO PARTS	Regional Water Operations	Lab supplies	\$15.87
<i>O'REILLY AUTO PARTS - Total For Regional Water Operations</i>			\$15.87
<b>O'REILLY AUTO PARTS - ALL DEPARTMENTS</b>			<b>\$99.82</b>

## OVERHEAD DOOR CO

OVERHEAD DOOR CO	Buildings & Structures Fund	Repairs	\$1,006.96
OVERHEAD DOOR CO	Buildings & Structures Fund	Services	\$679.76
<i>OVERHEAD DOOR CO - Total For Buildings &amp; Structures Fund</i>			\$1,686.72
<b>OVERHEAD DOOR CO - ALL DEPARTMENTS</b>			<b>\$1,686.72</b>

## OVERHEAD DOOR OF CAS

OVERHEAD DOOR OF CAS	Fire-EMS Operations	Repair on Station 3 Door	\$1,093.30
<i>OVERHEAD DOOR OF CAS - Total For Fire-EMS Operations</i>			\$1,093.30
<b>OVERHEAD DOOR OF CAS - ALL DEPARTMENTS</b>			<b>\$1,093.30</b>

## PACIFIC HIDE & FUR

PACIFIC HIDE & FUR	Refuse - Commercial	Container Maintenance	\$214.58
<i>PACIFIC HIDE &amp; FUR - Total For Refuse - Commercial</i>			\$214.58

**PACIFIC HIDE & FUR - ALL DEPARTMENTS** \$214.58

## **PACIFIC STEEL BRANCH**

PACIFIC STEEL BRANCH Water Distribution CONSTRUCTION MATERIALS - SQ. TUBE & SCH4 \$136.31

*PACIFIC STEEL BRANCH - Total For Water Distribution* \$136.31

**PACIFIC STEEL BRANCH - ALL DEPARTMENTS** \$136.31

## **PARTMASTER**

PARTMASTER Balefill - Disposal & Landfill PARTS WASHER RENT FOR 2 MONTHS \$750.00

*PARTMASTER - Total For Balefill - Disposal & Landfill* \$750.00

PARTMASTER WWTP Operations Ice Melt \$251.16

*PARTMASTER - Total For WWTP Operations* \$251.16

**PARTMASTER - ALL DEPARTMENTS** \$1,001.16

## **PAYPAL MEGHANRANKI**

PAYPAL MEGHANRANKI Rec Center - Operations Recreation Division Logo Design \$361.00

*PAYPAL MEGHANRANKI - Total For Rec Center - Operations* \$361.00

**PAYPAL MEGHANRANKI - ALL DEPARTMENTS** \$361.00

## **PEDEN'S INC**

PEDEN'S INC Police Career Services Uniforms \$351.00

PEDEN'S INC Police Career Services Uniforms \$154.00

*PEDEN'S INC - Total For Police Career Services* \$505.00

**PEDEN'S INC - ALL DEPARTMENTS** \$505.00

## **PLATTE RIVER PARKWAY**

PLATTE RIVER PARKWAY Capital Projects Fund Platte River Trails Trust \$30,000.00

*PLATTE RIVER PARKWAY - Total For Capital Projects Fund* \$30,000.00

**PLATTE RIVER PARKWAY - ALL DEPARTMENTS** \$30,000.00

## **POINT EMBLEMS LLC**



POINT EMBLEMS LLC	Police Administration	challenge coins for chief	\$930.00
<i>POINT EMBLEMS LLC - Total For Police Administration</i>			<i>\$930.00</i>
<b>POINT EMBLEMS LLC - ALL DEPARTMENTS</b>			<b>\$930.00</b>

## POSTAL PROS, INC.

POSTAL PROS, INC.	Customer Service	Services	\$2,194.51
POSTAL PROS, INC.	Customer Service	Services	\$2,771.58
POSTAL PROS, INC.	Customer Service	Services	\$3,038.98
POSTAL PROS, INC.	Customer Service	Services	\$3,019.94
POSTAL PROS, INC.	Customer Service	Services	\$2,939.08
POSTAL PROS, INC.	Customer Service	Services	\$2,146.78
<i>POSTAL PROS, INC. - Total For Customer Service</i>			<i>\$16,110.87</i>
<b>POSTAL PROS, INC. - ALL DEPARTMENTS</b>			<b>\$16,110.87</b>

## POWER EQUIPMENT CORP

POWER EQUIPMENT CORP	Balefill - Disposal & Landfill	Repairs	\$824.02
<i>POWER EQUIPMENT CORP - Total For Balefill - Disposal &amp; Landfill</i>			<i>\$824.02</i>
<b>POWER EQUIPMENT CORP - ALL DEPARTMENTS</b>			<b>\$824.02</b>

## PP WYOMINGWATE

PP WYOMINGWATE	WWTP Operations	WWQ/PCA Memberships	\$360.00
<i>PP WYOMINGWATE - Total For WWTP Operations</i>			<i>\$360.00</i>
<b>PP WYOMINGWATE - ALL DEPARTMENTS</b>			<b>\$360.00</b>

## PRINTWORKS

PRINTWORKS	Code Enforcement	Envelopes	\$170.16
<i>PRINTWORKS - Total For Code Enforcement</i>			<i>\$170.16</i>
<b>PRINTWORKS - ALL DEPARTMENTS</b>			<b>\$170.16</b>

## PYE BARKER - ROSWELL

PYE BARKER - ROSWELL	Fire-EMS Administration	Fire Alarm Inspection at Stations 2,3, and 6	\$570.00
<i>PYE BARKER - ROSWELL - Total For Fire-EMS Administration</i>			<i>\$570.00</i>

**PYE BARKER - ROSWELL - ALL DEPARTMENTS**

\$570.00

**QUALITY OFFICE SOLUT**

QUALITY OFFICE SOLUT	Parks - Parks Maint.	wet markers, label maker tape	\$57.13
QUALITY OFFICE SOLUT	Parks - Parks Maint.	Page dividers, post a notes writing pads	\$69.04
<i>QUALITY OFFICE SOLUT - Total For Parks - Parks Maint.</i>			<i>\$126.17</i>
QUALITY OFFICE SOLUT	Streets	wet markers, label maker tape	\$57.13
QUALITY OFFICE SOLUT	Streets	Page dividers, post a notes writing pads	\$57.11
<i>QUALITY OFFICE SOLUT - Total For Streets</i>			<i>\$114.24</i>

**QUALITY OFFICE SOLUT - ALL DEPARTMENTS**

\$240.41

**RECYKLING INDUSTRIAL**

RECYKLING INDUSTRIAL	Balefill - Baler Processing	Tech support	\$1,800.00
RECYKLING INDUSTRIAL	Balefill - Baler Processing	Tech support	\$1,700.00
<i>RECYKLING INDUSTRIAL - Total For Balefill - Baler Processing</i>			<i>\$3,500.00</i>

**RECYKLING INDUSTRIAL - ALL DEPARTMENTS**

\$3,500.00

**REXEL 3212**

REXEL 3212	Buildings & Structures Fund	Return of Supplies for Golf Course Pro Shop Re	(\$11.78)
REXEL 3212	Buildings & Structures Fund	Supplies for Golf Course Pro Shop Remodel	\$11.78
<i>REXEL 3212 - Total For Buildings &amp; Structures Fund</i>			<i>\$0.00</i>

**REXEL 3212 - ALL DEPARTMENTS**

\$0.00

**RMI CASPER**

RMI CASPER	WWTP Operations	Calibration gas	\$118.00
<i>RMI CASPER - Total For WWTP Operations</i>			<i>\$118.00</i>

**RMI CASPER - ALL DEPARTMENTS**

\$118.00

**Rocky Mountain**

Rocky Mountain	Regional Water Operations	Liquid Oxygen	\$3,539.01
<i>Rocky Mountain - Total For Regional Water Operations</i>			<i>\$3,539.01</i>
Rocky Mountain	Water Distribution	Supplies	\$21.47

Rocky Mountain - Total For Water Distribution \$21.47

**Rocky Mountain - ALL DEPARTMENTS \$3,560.48**

## ROCKY MOUNTAIN POWER

ROCKY MOUNTAIN POWER	Balefill - Disposal & Landfill	54730761-139 2	\$1,188.95
ROCKY MOUNTAIN POWER	Balefill - Disposal & Landfill	54730761-090 7	\$3,692.15
<i>ROCKY MOUNTAIN POWER - Total For Balefill - Disposal &amp; Landfill</i>			\$4,881.10
ROCKY MOUNTAIN POWER	Buildings & Structures Fund	54730761-089 9	\$151.05
<i>ROCKY MOUNTAIN POWER - Total For Buildings &amp; Structures Fund</i>			\$151.05
ROCKY MOUNTAIN POWER	Fire-EMS Administration	60445507-008 5	\$99.89
ROCKY MOUNTAIN POWER	Fire-EMS Administration	54730761-141 8	\$1,558.70
<i>ROCKY MOUNTAIN POWER - Total For Fire-EMS Administration</i>			\$1,658.59
ROCKY MOUNTAIN POWER	Ft. Caspar Museum	54730761-098 0	\$387.13
<i>ROCKY MOUNTAIN POWER - Total For Ft. Caspar Museum</i>			\$387.13
ROCKY MOUNTAIN POWER	Hogadon - Operations	54730761-126 9	\$3,751.12
ROCKY MOUNTAIN POWER	Hogadon - Operations	54730761-100 4	\$19,203.63
<i>ROCKY MOUNTAIN POWER - Total For Hogadon - Operations</i>			\$22,954.75
ROCKY MOUNTAIN POWER	Ice Arena - Operations	54730761-147 5	\$4,810.98
ROCKY MOUNTAIN POWER	Ice Arena - Operations	54730761-101 2	\$3,331.70
<i>ROCKY MOUNTAIN POWER - Total For Ice Arena - Operations</i>			\$8,142.68
ROCKY MOUNTAIN POWER	Parks - Athletic Maint.	54730761-131 9	\$1,722.08
<i>ROCKY MOUNTAIN POWER - Total For Parks - Athletic Maint.</i>			\$1,722.08
ROCKY MOUNTAIN POWER	Parks - Parks Maint.	54730761-103 8	\$3,425.20
ROCKY MOUNTAIN POWER	Parks - Parks Maint.	54730761-103 8	\$3,536.45
<i>ROCKY MOUNTAIN POWER - Total For Parks - Parks Maint.</i>			\$6,961.65
ROCKY MOUNTAIN POWER	Parks - Special Areas	54730761-132 7	\$3,552.02
ROCKY MOUNTAIN POWER	Parks - Special Areas	54730761-070 9	\$54.42
ROCKY MOUNTAIN POWER	Parks - Special Areas	54730761-132 7	\$1,809.31
<i>ROCKY MOUNTAIN POWER - Total For Parks - Special Areas</i>			\$5,415.75
ROCKY MOUNTAIN POWER	Police Administration	54730761-104 6	\$210.27
<i>ROCKY MOUNTAIN POWER - Total For Police Administration</i>			\$210.27
ROCKY MOUNTAIN POWER	Sewer Wastewater Collection	54730761-130 1	\$53.33
ROCKY MOUNTAIN POWER	Sewer Wastewater Collection	54730761-105 3	\$209.60
<i>ROCKY MOUNTAIN POWER - Total For Sewer Wastewater Collection</i>			\$262.93
ROCKY MOUNTAIN POWER	Traffic Control	60445507-010 1	\$7.15

<i>ROCKY MOUNTAIN POWER - Total For Traffic Control</i>			<i>\$7.15</i>
ROCKY MOUNTAIN POWER	Water Tanks	54730761-148 3	\$127.99
ROCKY MOUNTAIN POWER	Water Tanks	54730761-107 9	\$12,075.45
ROCKY MOUNTAIN POWER	Water Tanks	54730761-002 2	\$437.38
<i>ROCKY MOUNTAIN POWER - Total For Water Tanks</i>			<i>\$12,640.82</i>
ROCKY MOUNTAIN POWER	WWTP Operations	54730761-004 8	\$13.64
ROCKY MOUNTAIN POWER	WWTP Operations	54730761-108 7	\$51,572.37
<i>ROCKY MOUNTAIN POWER - Total For WWTP Operations</i>			<i>\$51,586.01</i>
<b>ROCKY MOUNTAIN POWER - ALL DEPARTMENTS</b>			<b>\$116,981.96</b>

## Router

Router	Parks - Parks Maint.	Provide/Install/Service Rented Invoice 53483	\$315.88
Router	Parks - Parks Maint.	Provide/Install/Service Rented	\$99.44
Router	Parks - Parks Maint.	Provide/Install/Service Rented Invoice 53484	\$216.44
<i>Router - Total For Parks - Parks Maint.</i>			<i>\$631.76</i>
<b>Router - ALL DEPARTMENTS</b>			<b>\$631.76</b>

## S & M ELECTRIC

S & M ELECTRIC	Balefill - Disposal & Landfill	Services	\$362.75
<i>S &amp; M ELECTRIC - Total For Balefill - Disposal &amp; Landfill</i>			<i>\$362.75</i>
<b>S &amp; M ELECTRIC - ALL DEPARTMENTS</b>			<b>\$362.75</b>

## SAFE KIDS WORLDWIDE

SAFE KIDS WORLDWIDE	Fire-EMS Training	Recertification fee for Dane Andersen	\$55.00
<i>SAFE KIDS WORLDWIDE - Total For Fire-EMS Training</i>			<i>\$55.00</i>
<b>SAFE KIDS WORLDWIDE - ALL DEPARTMENTS</b>			<b>\$55.00</b>

## SAMS CLUB #6425

SAMS CLUB #6425	Rec Center - Admin	Holiday Camp Supplies & Office Supplies	\$9.98
<i>SAMS CLUB #6425 - Total For Rec Center - Admin</i>			<i>\$9.98</i>
SAMS CLUB #6425	Rec Center - Classes	Holiday Camp Supplies & Office Supplies	\$46.88
<i>SAMS CLUB #6425 - Total For Rec Center - Classes</i>			<i>\$46.88</i>
SAMS CLUB #6425	Sewer Wastewater Collection	office supplies	\$44.16

SAMS CLUB #6425 - Total For Sewer Wastewater Collection \$44.16

**SAMS CLUB #6425 - ALL DEPARTMENTS \$101.02**

## SAMSCLUB.COM

SAMSCLUB.COM Fire-EMS Operations Station Supplies \$19.96

*SAMSCLUB.COM - Total For Fire-EMS Operations \$19.96*

SAMSCLUB.COM Refuse - Residential TRUCK BARN COFFEE AND PAPER TOWELS \$80.78

*SAMSCLUB.COM - Total For Refuse - Residential \$80.78*

**SAMSCLUB.COM - ALL DEPARTMENTS \$100.74**

## SELF HELP CENTER, IN

SELF HELP CENTER, IN Capital Projects Fund 1% #16 Funding Self Help Cente \$11,027.75

*SELF HELP CENTER, IN - Total For Capital Projects Fund \$11,027.75*

**SELF HELP CENTER, IN - ALL DEPARTMENTS \$11,027.75**

## SHELL OIL 5744427920

SHELL OIL 5744427920 Fire-EMS Operations Fuel \$39.05

SHELL OIL 5744427920 Fire-EMS Operations Fuel \$26.44

SHELL OIL 5744427920 Fire-EMS Operations Fuel \$50.00

SHELL OIL 5744427920 Fire-EMS Operations Fuel \$43.86

SHELL OIL 5744427920 Fire-EMS Operations Fuel \$20.00

*SHELL OIL 5744427920 - Total For Fire-EMS Operations \$179.35*

**SHELL OIL 5744427920 - ALL DEPARTMENTS \$179.35**

## SHERWIN-WILLIAMS COR

SHERWIN-WILLIAMS COR Balefill - Baler Processing Paint \$338.29

*SHERWIN-WILLIAMS COR - Total For Balefill - Baler Processing \$338.29*

SHERWIN-WILLIAMS COR Buildings & Structures Fund Return paint (\$86.37)

SHERWIN-WILLIAMS COR Buildings & Structures Fund Paint supplies \$21.59

SHERWIN-WILLIAMS COR Buildings & Structures Fund Paint & supplies \$175.41

SHERWIN-WILLIAMS COR Buildings & Structures Fund Paint \$158.95

*SHERWIN-WILLIAMS COR - Total For Buildings & Structures Fund \$269.58*

**SHERWIN-WILLIAMS COR - ALL DEPARTMENTS** \$607.87

### **SIMPLOT T&H DEN**

SIMPLOT T&H DEN Weed & Pest Fund Herbicide \$1,881.00

*SIMPLOT T&H DEN - Total For Weed & Pest Fund* \$1,881.00

**SIMPLOT T&H DEN - ALL DEPARTMENTS** \$1,881.00

### **SMITH PSYCHOLOGICAL**

SMITH PSYCHOLOGICAL Police Administration Medical Matters \$400.00

SMITH PSYCHOLOGICAL Police Administration Medical Matters \$1,025.00

*SMITH PSYCHOLOGICAL - Total For Police Administration* \$1,425.00

SMITH PSYCHOLOGICAL Police Career Services Pre-employment testing \$400.00

SMITH PSYCHOLOGICAL Police Career Services Pre-employment testing \$400.00

*SMITH PSYCHOLOGICAL - Total For Police Career Services* \$800.00

**SMITH PSYCHOLOGICAL - ALL DEPARTMENTS** \$2,225.00

### **SMITHS FOOD #4185**

SMITHS FOOD #4185 Balefill - Diversion & Special LAUNDRY DETERGENT SPEC WASTE BLDG \$22.99

*SMITHS FOOD #4185 - Total For Balefill - Diversion & Special* \$22.99

**SMITHS FOOD #4185 - ALL DEPARTMENTS** \$22.99

### **SPORTSMANS INTERNET**

SPORTSMANS INTERNET Police Career Services uniform items \$146.99

SPORTSMANS INTERNET Police Career Services uniform items \$325.44

SPORTSMANS INTERNET Police Career Services uniforms \$78.74

*SPORTSMANS INTERNET - Total For Police Career Services* \$551.17

**SPORTSMANS INTERNET - ALL DEPARTMENTS** \$551.17

### **SQ ASPEN GARAGE DOO**

SQ ASPEN GARAGE DOO Water Distribution GARAGE DOOR REPAIR \$85.00

*SQ ASPEN GARAGE DOO - Total For Water Distribution* \$85.00

**SQ ASPEN GARAGE DOO - ALL DEPARTMENTS** \$85.00

### **SQ BOURGEOIS PIG**

SQ BOURGEOIS PIG Human Resources 10, \$5 gift certificates for gift card giveaway Bo \$50.00

*SQ BOURGEOIS PIG - Total For Human Resources* \$50.00

**SQ BOURGEOIS PIG - ALL DEPARTMENTS** \$50.00

### **SQ EILEEN'S COLOSSA**

SQ EILEEN'S COLOSSA Human Resources 1/2 dozen cookies for CWC \$2.90

*SQ EILEEN'S COLOSSA - Total For Human Resources* \$2.90

**SQ EILEEN'S COLOSSA - ALL DEPARTMENTS** \$2.90

### **SQ FROSTED TOPS**

SQ FROSTED TOPS Human Resources 2, \$25 gift cards for gift card giveaway Frosted T \$50.00

*SQ FROSTED TOPS - Total For Human Resources* \$50.00

**SQ FROSTED TOPS - ALL DEPARTMENTS** \$50.00

### **SQ METRO COFFEE COM**

SQ METRO COFFEE COM Human Resources 5, \$10 gift cards for giveaway Metro Coffee Co. \$50.00

*SQ METRO COFFEE COM - Total For Human Resources* \$50.00

**SQ METRO COFFEE COM - ALL DEPARTMENTS** \$50.00

### **SQ MY EDUCATIONAL R**

SQ MY EDUCATIONAL R Fire-EMS Training ACLS Certification for Chief Siplon \$14.00

*SQ MY EDUCATIONAL R - Total For Fire-EMS Training* \$14.00

**SQ MY EDUCATIONAL R - ALL DEPARTMENTS** \$14.00

### **STANTEC CONSULTING S**

STANTEC CONSULTING S Capital Projects Fund CONTRACT FOR CA ON THE NPRR 1S \$10,788.37

*STANTEC CONSULTING S - Total For Capital Projects Fund* \$10,788.37

**STANTEC CONSULTING S - ALL DEPARTMENTS**

\$10,788.37

**STAPLES**

STAPLES	Balefill - Baler Processing	WI FI BOOST FOR PLAZMA TABLE	\$199.98
---------	-----------------------------	------------------------------	----------

<i>STAPLES - Total For Balefill - Baler Processing</i>			\$199.98
--	--	--	----------

STAPLES	Parks - Parks Maint.	Desk calendar for Randy	\$5.99
---------	----------------------	-------------------------	--------

<i>STAPLES - Total For Parks - Parks Maint.</i>			\$5.99
---	--	--	--------

STAPLES	Streets	Mouse bundles for new lab tops	\$66.97
---------	---------	--------------------------------	---------

<i>STAPLES - Total For Streets</i>			\$66.97
------------------------------------	--	--	---------

**STAPLES - ALL DEPARTMENTS**

\$272.94

**STAPLES DIRECT**

STAPLES DIRECT	Customer Service	CARTRIDGES FOR EPSON CHECK PRINTERS	\$173.20
----------------	------------------	-------------------------------------	----------

<i>STAPLES DIRECT - Total For Customer Service</i>			\$173.20
--	--	--	----------

**STAPLES DIRECT - ALL DEPARTMENTS**

\$173.20

**STARBUCKS STORE**

STARBUCKS STORE	Human Resources	5, \$10 gift cards for gift card giveaway Starbucks	\$50.00
-----------------	-----------------	---	---------

<i>STARBUCKS STORE - Total For Human Resources</i>			\$50.00
--	--	--	---------

**STARBUCKS STORE - ALL DEPARTMENTS**

\$50.00

**STOTZ EQUIPMENT**

STOTZ EQUIPMENT	Fire-EMS Operations	Saw maintenance supplies, repairs and replace	\$234.25
-----------------	---------------------	---	----------

<i>STOTZ EQUIPMENT - Total For Fire-EMS Operations</i>			\$234.25
--	--	--	----------

**STOTZ EQUIPMENT - ALL DEPARTMENTS**

\$234.25

**SUMMIT ELECTRIC LLC.**

SUMMIT ELECTRIC LLC.	Buildings & Structures Fund	Work performed	\$150.00
----------------------	-----------------------------	----------------	----------

SUMMIT ELECTRIC LLC.	Buildings & Structures Fund	Work performed	\$55.00
----------------------	-----------------------------	----------------	---------

<i>SUMMIT ELECTRIC LLC. - Total For Buildings &amp; Structures Fund</i>			\$205.00
---	--	--	----------

**SUMMIT ELECTRIC LLC. - ALL DEPARTMENTS**

\$205.00



## TELEFLEX LLC

TELEFLEX LLC	Fire-EMS Operations	Power Driver	\$612.50
<i>TELEFLEX LLC - Total For Fire-EMS Operations</i>			<i>\$612.50</i>
<b>TELEFLEX LLC - ALL DEPARTMENTS</b>			<b>\$612.50</b>

## THATCHER CO.

THATCHER CO.	WWTP Regional Interceptors	Ferrous Chloride delivery on 12/18/2020.	\$9,536.37
<i>THATCHER CO. - Total For WWTP Regional Interceptors</i>			<i>\$9,536.37</i>
<b>THATCHER CO. - ALL DEPARTMENTS</b>			<b>\$9,536.37</b>

## THE HOME DEPOT

THE HOME DEPOT	Balefill - Baler Processing	BALER BLDG SUPPLIES	\$128.66
<i>THE HOME DEPOT - Total For Balefill - Baler Processing</i>			<i>\$128.66</i>
THE HOME DEPOT	Buildings & Structures Fund	BAS Shop Tools - Return	(\$37.94)
THE HOME DEPOT	Buildings & Structures Fund	BAS Shop Tools	\$37.94
THE HOME DEPOT	Buildings & Structures Fund	Antifreeze for City Hall Flagpoles	\$2.98
THE HOME DEPOT	Buildings & Structures Fund	Supplies for Pro Shop Remodel	\$128.24
THE HOME DEPOT	Buildings & Structures Fund	BAS Shop Tools	\$39.94
<i>THE HOME DEPOT - Total For Buildings &amp; Structures Fund</i>			<i>\$171.16</i>
THE HOME DEPOT	Fire-EMS Operations	Bar, Nuts, ready mix concrete	\$33.29
<i>THE HOME DEPOT - Total For Fire-EMS Operations</i>			<i>\$33.29</i>
THE HOME DEPOT	Hogadon - Operations	Magic carpet repair	\$29.42
THE HOME DEPOT	Hogadon - Operations	Lift repairs	\$30.92
<i>THE HOME DEPOT - Total For Hogadon - Operations</i>			<i>\$60.34</i>
THE HOME DEPOT	Parks - Parks Maint.	Parks Supplies	\$175.95
<i>THE HOME DEPOT - Total For Parks - Parks Maint.</i>			<i>\$175.95</i>
THE HOME DEPOT	Rec Center - Operations	Custodial Repair Supplies	\$38.59
<i>THE HOME DEPOT - Total For Rec Center - Operations</i>			<i>\$38.59</i>
THE HOME DEPOT	Refuse - Residential	TOOLS FOR CONTAINER REPAIR	\$64.93
<i>THE HOME DEPOT - Total For Refuse - Residential</i>			<i>\$64.93</i>
THE HOME DEPOT	Traffic Control	Hammer drill bit to fix the gate at 26th & McKinl	\$49.97
<i>THE HOME DEPOT - Total For Traffic Control</i>			<i>\$49.97</i>
THE HOME DEPOT	Weed & Pest Fund	Office supplies	\$79.97

THE HOME DEPOT - Total For Weed & Pest Fund \$79.97

**THE HOME DEPOT - ALL DEPARTMENTS \$802.86**

## THE OFFICE SHOP, INC

THE OFFICE SHOP, INC Fire-EMS Administration November copier usage fee \$8.52

THE OFFICE SHOP, INC - Total For Fire-EMS Administration \$8.52

**THE OFFICE SHOP, INC - ALL DEPARTMENTS \$8.52**

## THE UPS STORE

THE UPS STORE Balefill - Disposal & Landfill SHIPMENT ON PUMPS (LEACHATE) \$520.60

THE UPS STORE - Total For Balefill - Disposal & Landfill \$520.60

THE UPS STORE Sewer Wastewater Collection shipping of wet well wizard starters \$20.28

THE UPS STORE - Total For Sewer Wastewater Collection \$20.28

**THE UPS STORE - ALL DEPARTMENTS \$540.88**

## TOP OFFICE PRODUCTS

TOP OFFICE PRODUCTS WWTP Operations Copy charges July 2020 \$153.50

TOP OFFICE PRODUCTS - Total For WWTP Operations \$153.50

**TOP OFFICE PRODUCTS - ALL DEPARTMENTS \$153.50**

## TOWNSQUARE MEDIA, IN

TOWNSQUARE MEDIA, IN Hogadon - Operations ADVERTISING SERVICES \$492.00

TOWNSQUARE MEDIA, IN - Total For Hogadon - Operations \$492.00

TOWNSQUARE MEDIA, IN Sewer Wastewater Collection ADVERTISING SERVICES \$120.00

TOWNSQUARE MEDIA, IN - Total For Sewer Wastewater Collection \$120.00

TOWNSQUARE MEDIA, IN WWTP Operations ADVERTISING SERVICES \$120.00

TOWNSQUARE MEDIA, IN - Total For WWTP Operations \$120.00

**TOWNSQUARE MEDIA, IN - ALL DEPARTMENTS \$732.00**

## TRANSMISSION DISTRIB

TRANSMISSION DISTRIB Capital Projects Fund Contract Withholding: 20300422 \$7,325.86

TRANSMISSION DISTRIB - Total For Capital Projects Fund \$7,325.86

**TRANSMISSION DISTRIB - ALL DEPARTMENTS** \$7,325.86

**TRETO CONST.**

TRETO CONST. Water Revenue and Transfers 2017 CPU Asphalt repair - retainage release \$10,812.50

*TRETO CONST. - Total For Water Revenue and Transfers* \$10,812.50

**TRETO CONST. - ALL DEPARTMENTS** \$10,812.50

**TRI STATE OIL RECLAI**

TRI STATE OIL RECLAI Balefill - Diversion & Special Contractor \$100.00

*TRI STATE OIL RECLAI - Total For Balefill - Diversion & Special* \$100.00

**TRI STATE OIL RECLAI - ALL DEPARTMENTS** \$100.00

**TST CITY BREW COFFE**

TST CITY BREW COFFE Human Resources 5, \$10 gift cards for gift card giveaway City Brew \$50.00

*TST CITY BREW COFFE - Total For Human Resources* \$50.00

**TST CITY BREW COFFE - ALL DEPARTMENTS** \$50.00

**TST EGGINGTON S**

TST EGGINGTON S Human Resources 3, \$50 gift cards for gift card giveaway Eggingto \$150.00

*TST EGGINGTON S - Total For Human Resources* \$150.00

**TST EGGINGTON S - ALL DEPARTMENTS** \$150.00

**TST RACCA S PIZZERI**

TST RACCA S PIZZERI Human Resources 3, \$50 gift cards for giveaway Racca's \$150.00

*TST RACCA S PIZZERI - Total For Human Resources* \$150.00

**TST RACCA S PIZZERI - ALL DEPARTMENTS** \$150.00

**TST WYOMING RIB**

TST WYOMING RIB City Manager Lunch meeting \$44.60

*TST WYOMING RIB - Total For City Manager* \$44.60

TST WYOMING RIB Human Resources 3, \$50 gift cards for giveaway Rib & Chop House \$150.00

TST WYOMING RIB - Total For Human Resources \$150.00

**TST WYOMING RIB - ALL DEPARTMENTS \$194.60**

## TYLER TECHNOLOGIES I

TYLER TECHNOLOGIES I Balefill - Disposal & Landfill Gems S028911 - Tyler Conversio \$168.00

TYLER TECHNOLOGIES I Balefill - Disposal & Landfill Gems S028911 - Tyler Conversio \$28.00

*TYLER TECHNOLOGIES I - Total For Balefill - Disposal & Landfill \$196.00*

TYLER TECHNOLOGIES I Capital Projects Fund Gems S028911 - Tyler Conversio \$483.00

TYLER TECHNOLOGIES I Capital Projects Fund Gems S028911 - Tyler Conversio \$2,898.00

*TYLER TECHNOLOGIES I - Total For Capital Projects Fund \$3,381.00*

TYLER TECHNOLOGIES I Refuse - Residential Gems S028911 - Tyler Conversio \$252.00

TYLER TECHNOLOGIES I Refuse - Residential Gems S028911 - Tyler Conversio \$42.00

*TYLER TECHNOLOGIES I - Total For Refuse - Residential \$294.00*

TYLER TECHNOLOGIES I Regional Water Operations Gems S028911 - Tyler Conversio \$7.00

TYLER TECHNOLOGIES I Regional Water Operations Gems S028911 - Tyler Conversio \$42.00

*TYLER TECHNOLOGIES I - Total For Regional Water Operations \$49.00*

TYLER TECHNOLOGIES I Sewer Wastewater Collection Gems S028911 - Tyler Conversio \$35.00

TYLER TECHNOLOGIES I Sewer Wastewater Collection Gems S028911 - Tyler Conversio \$210.00

*TYLER TECHNOLOGIES I - Total For Sewer Wastewater Collection \$245.00*

TYLER TECHNOLOGIES I Water Distribution Gems S028911 - Tyler Conversio \$462.00

TYLER TECHNOLOGIES I Water Distribution Gems S028911 - Tyler Conversio \$77.00

*TYLER TECHNOLOGIES I - Total For Water Distribution \$539.00*

TYLER TECHNOLOGIES I WWTP Operations Gems S028911 - Tyler Conversio \$168.00

TYLER TECHNOLOGIES I WWTP Operations Gems S028911 - Tyler Conversio \$28.00

*TYLER TECHNOLOGIES I - Total For WWTP Operations \$196.00*

**TYLER TECHNOLOGIES I - ALL DEPARTMENTS \$4,900.00**

## UNIFORM ADVANTAGE

UNIFORM ADVANTAGE Metro Animal Shelter scrubs \$120.93

*UNIFORM ADVANTAGE - Total For Metro Animal Shelter \$120.93*

**UNIFORM ADVANTAGE - ALL DEPARTMENTS \$120.93**

## UNIFORMS 2 GEAR

UNIFORMS 2 GEAR	Police Career Services	Supplies	\$1,463.02
<i>UNIFORMS 2 GEAR - Total For Police Career Services</i>			<i>\$1,463.02</i>
<b>UNIFORMS 2 GEAR - ALL DEPARTMENTS</b>			<b>\$1,463.02</b>

### UPS 0000008F045W021

UPS 0000008F045W021	Regional Water Operations	Ship Lab Test	\$146.67
<i>UPS 0000008F045W021 - Total For Regional Water Operations</i>			<i>\$146.67</i>
<b>UPS 0000008F045W021 - ALL DEPARTMENTS</b>			<b>\$146.67</b>

### URGENT CARE OF CASPE

URGENT CARE OF CASPE	Property Insurance Fund	MEDICAL SERVICES & HEALTH PRACTITIONERS	\$1,966.00
<i>URGENT CARE OF CASPE - Total For Property Insurance Fund</i>			<i>\$1,966.00</i>
<b>URGENT CARE OF CASPE - ALL DEPARTMENTS</b>			<b>\$1,966.00</b>

### USPS PO 5715580945

USPS PO 5715580945	City Manager	POSTAGE STAMPS	\$55.00
<i>USPS PO 5715580945 - Total For City Manager</i>			<i>\$55.00</i>
USPS PO 5715580945	River Restoration	POSTAGE STAMPS	\$8.25
<i>USPS PO 5715580945 - Total For River Restoration</i>			<i>\$8.25</i>
<b>USPS PO 5715580945 - ALL DEPARTMENTS</b>			<b>\$63.25</b>

### VERIZON WIRELESS

VERIZON WIRELESS	Buildings & Structures Fund	Services	\$86.78
<i>VERIZON WIRELESS - Total For Buildings &amp; Structures Fund</i>			<i>\$86.78</i>
VERIZON WIRELESS	Code Enforcement	Services	\$173.36
<i>VERIZON WIRELESS - Total For Code Enforcement</i>			<i>\$173.36</i>
VERIZON WIRELESS	Police Administration	Credit Memo	(\$298.30)
<i>VERIZON WIRELESS - Total For Police Administration</i>			<i>(\$298.30)</i>
VERIZON WIRELESS	Public Safety Communication	Command Bus	\$80.02
<i>VERIZON WIRELESS - Total For Public Safety Communications</i>			<i>\$80.02</i>
<b>VERIZON WIRELESS - ALL DEPARTMENTS</b>			<b>\$41.86</b>

## VERMEER SALES & SERV

VERMEER SALES & SERV	Balefill - Diversion & Special	Vermeer Grinder infeed planetary - unit 141486	\$2,667.44
<i>VERMEER SALES &amp; SERV - Total For Balefill - Diversion &amp; Special</i>			<i>\$2,667.44</i>
<b>VERMEER SALES &amp; SERV - ALL DEPARTMENTS</b>			<b>\$2,667.44</b>

## VRC COMPANIES LLC

VRC COMPANIES LLC	Municipal Court	Contracted Storage	\$99.75
<i>VRC COMPANIES LLC - Total For Municipal Court</i>			<i>\$99.75</i>
<b>VRC COMPANIES LLC - ALL DEPARTMENTS</b>			<b>\$99.75</b>

## VZWRLSS IVR VB

VZWRLSS IVR VB	Cemetery	TELECOMMUNICATION SERV.INCLUD. LOCAL/L.	\$40.01
<i>VZWRLSS IVR VB - Total For Cemetery</i>			<i>\$40.01</i>
VZWRLSS IVR VB	Sewer Wastewater Collection	remote device data	\$74.46
<i>VZWRLSS IVR VB - Total For Sewer Wastewater Collection</i>			<i>\$74.46</i>
VZWRLSS IVR VB	Streets	Monthly bill for Streets on call and Traffic hotsp	\$66.46
<i>VZWRLSS IVR VB - Total For Streets</i>			<i>\$66.46</i>
VZWRLSS IVR VB	WWTP Operations	TELECOMMUNICATION SERV.INCLUD. LOCAL/L.	\$145.15
<i>VZWRLSS IVR VB - Total For WWTP Operations</i>			<i>\$145.15</i>
<b>VZWRLSS IVR VB - ALL DEPARTMENTS</b>			<b>\$326.08</b>

## VZWRLSS MY VZ VB P

VZWRLSS MY VZ VB P	Fire-EMS Administration	November Air Card Bill	\$120.03
VZWRLSS MY VZ VB P	Fire-EMS Administration	November Cell Phone Bill	\$1,480.37
<i>VZWRLSS MY VZ VB P - Total For Fire-EMS Administration</i>			<i>\$1,600.40</i>
VZWRLSS MY VZ VB P	Regional Water Operations	WTP Operator Cell Phone	\$26.45
<i>VZWRLSS MY VZ VB P - Total For Regional Water Operations</i>			<i>\$26.45</i>
<b>VZWRLSS MY VZ VB P - ALL DEPARTMENTS</b>			<b>\$1,626.85</b>

## WAL-MART #1617

WAL-MART #1617	Balefill - Disposal & Landfill	BLEACH FOR LEACHATE SYS CLOGS	\$52.92
<i>WAL-MART #1617 - Total For Balefill - Disposal &amp; Landfill</i>			<i>\$52.92</i>

WAL-MART #1617	Balefill - Diversion & Special	TRAC PHONE FOR ON CALL, HAND SANI, RODEN	\$149.81
<i>WAL-MART #1617 - Total For Balefill - Diversion &amp; Special</i>			<i>\$149.81</i>
WAL-MART #1617	Fire-EMS Administration	Office Supplies	\$67.46
<i>WAL-MART #1617 - Total For Fire-EMS Administration</i>			<i>\$67.46</i>
<b>WAL-MART #1617 - ALL DEPARTMENTS</b>			<b>\$270.19</b>

## WALTER KIDDE PORTABL

WALTER KIDDE PORTABL	Fire-EMS Prevent & Inspect	Smoke Alarms	\$1,699.84
<i>WALTER KIDDE PORTABL - Total For Fire-EMS Prevent &amp; Inspect</i>			<i>\$1,699.84</i>
<b>WALTER KIDDE PORTABL - ALL DEPARTMENTS</b>			<b>\$1,699.84</b>

## WEAR PARTS INC

WEAR PARTS INC	Buildings & Structures Fund	Lock repair parts for Water Distribution	\$35.53
<i>WEAR PARTS INC - Total For Buildings &amp; Structures Fund</i>			<i>\$35.53</i>
WEAR PARTS INC	Golf - Operations	Flange nuts for fairway mower reels	\$7.94
<i>WEAR PARTS INC - Total For Golf - Operations</i>			<i>\$7.94</i>
<b>WEAR PARTS INC - ALL DEPARTMENTS</b>			<b>\$43.47</b>

## WEST PLAINS ENGINEER

WEST PLAINS ENGINEER	Capital Projects Fund	Mechanical Study of the CEC PI	\$4,470.00
<i>WEST PLAINS ENGINEER - Total For Capital Projects Fund</i>			<i>\$4,470.00</i>
<b>WEST PLAINS ENGINEER - ALL DEPARTMENTS</b>			<b>\$4,470.00</b>

## WESTERN WYOMING LOCK

WESTERN WYOMING LOCK	Buildings & Structures Fund	Locksmith to repair door locks for PD at Marath	\$115.00
<i>WESTERN WYOMING LOCK - Total For Buildings &amp; Structures Fund</i>			<i>\$115.00</i>
<b>WESTERN WYOMING LOCK - ALL DEPARTMENTS</b>			<b>\$115.00</b>

## WINN-MARION BARBER,

WINN-MARION BARBER,	Regional Water Operations	Paid freight which was missed on original paym	\$19.34
WINN-MARION BARBER,	Regional Water Operations	Credit for tax on invoice 3290216	(\$82.06)
WINN-MARION BARBER,	Regional Water Operations	Parts for Magmeter (flowmeter)	\$1,723.31

WINN-MARION BARBER, - Total For Regional Water Operations	\$1,660.59
<b>WINN-MARION BARBER, - ALL DEPARTMENTS</b>	<b>\$1,660.59</b>

## WLC ENGINEERING - SU

WLC ENGINEERING - SU	Engineering	Services	\$72.50
<i>WLC ENGINEERING - SU - Total For Engineering</i>			<i>\$72.50</i>
<b>WLC ENGINEERING - SU - ALL DEPARTMENTS</b>			<b>\$72.50</b>

## WM SUPERCENTER

WM SUPERCENTER	Balefill - Disposal & Landfill	DRINKS FOR COVID TESTING EMPLOYEES	\$34.61
<i>WM SUPERCENTER - Total For Balefill - Disposal &amp; Landfill</i>			<i>\$34.61</i>
WM SUPERCENTER	Fire-EMS Operations	Batteries - Station Supplies	\$36.45
<i>WM SUPERCENTER - Total For Fire-EMS Operations</i>			<i>\$36.45</i>
WM SUPERCENTER	Metro Animal Shelter	scrubs for new kennel tech	\$84.60
<i>WM SUPERCENTER - Total For Metro Animal Shelter</i>			<i>\$84.60</i>
WM SUPERCENTER	Rec Center - Operations	Frames for Occupancy Numbers	\$17.22
<i>WM SUPERCENTER - Total For Rec Center - Operations</i>			<i>\$17.22</i>
<b>WM SUPERCENTER - ALL DEPARTMENTS</b>			<b>\$172.88</b>

## WOODWORKERS SUPPLY I

WOODWORKERS SUPPLY I	Balefill - Baler Processing	BALER PARTS	\$29.38
<i>WOODWORKERS SUPPLY I - Total For Balefill - Baler Processing</i>			<i>\$29.38</i>
WOODWORKERS SUPPLY I	Buildings & Structures Fund	Supplies to build cabinet for Golf Course Pro Sh	\$69.12
WOODWORKERS SUPPLY I	Buildings & Structures Fund	Supplies to build cabinet for Golf Course Pro Sh	\$63.30
<i>WOODWORKERS SUPPLY I - Total For Buildings &amp; Structures Fund</i>			<i>\$132.42</i>
<b>WOODWORKERS SUPPLY I - ALL DEPARTMENTS</b>			<b>\$161.80</b>

## WORDPRESS UPU66ULYR8

WORDPRESS UPU66ULYR8	Police Administration	renew annual subscription	\$300.00
<i>WORDPRESS UPU66ULYR8 - Total For Police Administration</i>			<i>\$300.00</i>
<b>WORDPRESS UPU66ULYR8 - ALL DEPARTMENTS</b>			<b>\$300.00</b>



## WY. RENTS, LLC.

WY. RENTS, LLC.	Golf - Operations	Replacement Blade for carpet stripper rental	\$13.00
WY. RENTS, LLC.	Golf - Operations	Floor Stripper for carpet removal in Pro Shop	\$60.00

*WY. RENTS, LLC. - Total For Golf - Operations* \$73.00

**WY. RENTS, LLC. - ALL DEPARTMENTS** \$73.00

## WY. WATER QUALITY &

WY. WATER QUALITY &	Sewer Wastewater Collection Membership fees		\$60.00
---------------------	---	--	---------

*WY. WATER QUALITY & - Total For Sewer Wastewater Collection* \$60.00

**WY. WATER QUALITY & - ALL DEPARTMENTS** \$60.00

## WYOMING LOW VOLTAGE

WYOMING LOW VOLTAGE	Golf - Operations	Technology Items (computers, software, and ne	\$410.00
---------------------	-------------------	---	----------

*WYOMING LOW VOLTAGE - Total For Golf - Operations* \$410.00

**WYOMING LOW VOLTAGE - ALL DEPARTMENTS** \$410.00

## WYOMING STEEL & RECY

WYOMING STEEL & RECY	Balefill - Baler Processing	Metal	\$1,750.00
----------------------	-----------------------------	-------	------------

*WYOMING STEEL & RECY - Total For Balefill - Baler Processing* \$1,750.00

WYOMING STEEL & RECY	Refuse - Recycling	Recycling	\$8,009.40
----------------------	--------------------	-----------	------------

*WYOMING STEEL & RECY - Total For Refuse - Recycling* \$8,009.40

**WYOMING STEEL & RECY - ALL DEPARTMENTS** \$9,759.40

## XEROX CORPORATION

XEROX CORPORATION	Engineering	Copies	\$204.22
-------------------	-------------	--------	----------

XEROX CORPORATION	Engineering	Copier base charge	\$38.96
-------------------	-------------	--------------------	---------

*XEROX CORPORATION - Total For Engineering* \$243.18

**XEROX CORPORATION - ALL DEPARTMENTS** \$243.18

**CITYWIDE BILLS AND CLAIMS TOTAL**

\$2,134,232.39

---

I certify, under penalty of perjury, that this listing of vouchers and the items included therein for payment are correct and just in every respect.

SUBMITTED BY (Finance Dir) \_\_\_\_\_ DATE \_\_\_\_\_

---

DULY AUDITED BY (City Manager) \_\_\_\_\_ DATE \_\_\_\_\_

APPROVED BY (Mayor) \_\_\_\_\_ DATE \_\_\_\_\_

CITY of CASPER, WYOMING  
 BILLS and CLAIMS ADDENDUM  
 Council Meeting  
 02/02/21

**Additional Accounts Payable**

<b><u>01/14/21</u></b>	Prewrits - vendors, sales tax, petty cash, reimbursement	899.40
	Emergency Medical Direction	213.50
	Steve Nunn	192.56
	First Interstate Bank - Petty Cash	107.00
	First Interstate Bank - Petty Cash	28,151.70
	Moore & Associates	99,500.00
	Casper Area Convention	304.94
	State of Wy - Dept of Revenue	<u>304.94</u>
		129,369.10
<b><u>01/20/21</u></b>	Micro Motion	480.00
		<u>480.00</u>
<b><u>01/21/21</u></b>	Prewrits - reissue, petty cash, background checks	
	Emaint Enterprises, LLC	3,300.00
	First Interstate Bank - Petty Cash	285.00
	State of Wy - Div of Criminal Invest	39.00
	State of Wy - Div of Criminal Invest	<u>39.00</u>
		3,663.00
	<b>Total Additional AP</b>	<b><u><u>\$ 133,512.10</u></u></b>

January 28, 2021

MEMO TO: J. Carter Napier, City Manager 

FROM: Liz Becher, Community Development Director 

SUBJECT: Establish Date of Public Hearing for Consideration of an Ordinance Approving a Vacation and Replat Creating the Trails West Estates No. 4 Addition, a Zone Change of Said Subdivision, and the Trails West Estates No. 4 Subdivision Agreement

Meeting Type & Date:

Regular Council Meeting, February 2, 2021

Action Type:

Establish date of public hearing

Recommendation:

That Council, by minute action, establish February 16, 2021 as the date of public hearing for consideration of an Ordinance approving a vacation and replat creating Trails West Estates No. 4 Addition, a zone change of the proposed Trails West Estates No. 4 Addition, and the Trails West Estates No. 4 Subdivision Agreement.

Summary:

Application has been made to create a new subdivision, Trails West Estates No. 4. The subdivision encompasses 30.59-acres, more or less, and is creating eighteen (18) newly configured residential lots. In that the property involved currently consists of both R-1 (Residential Estate) and PUD (Planned Unit Development) zoning, the application also includes a zone change to consolidate all the zoning into R-1 (Residential Estate). All proposed lots in the newly configured subdivision are currently undeveloped, with the exception of Lots 17 and 18, which both have existing residential structures. All reconfigured lots meet or exceed the minimum 9,000 square foot lot minimum in the R-1 (Residential Estate) zoning district, and all have direct access/frontage on a public street. The primary purpose of the proposed replat is to vacate Indian Scout Drive, and reconfigure all lots previously served by Indian Scout Drive so that they have legal access to a public street (Trevett Lane). Indian Scout Drive is a platted, but undeveloped public right-of-way located south of Trevett Lane. As a result of the replat, the property owners in the area will be relieved of their future obligation to pay for the construction of the street.

The Planning and Zoning Commission voted to support the vacation, replat and zone change after a public hearing on January 21, 2021. There were no public comments submitted. A notice of public hearing will be published in the Casper Star-Tribune advertising the City Council public hearing. All public hearings are also advertised on the Council agenda page of the City's

website (casperwy.gov), and notices are mailed to all property owners within three hundred (300) feet.

Financial Considerations:

None

Oversight/Project Responsibility:

The Community Development Department processes vacations, replats and zone changes

Attachments:

Location/Zoning Map



# Trails West Estates No. 4

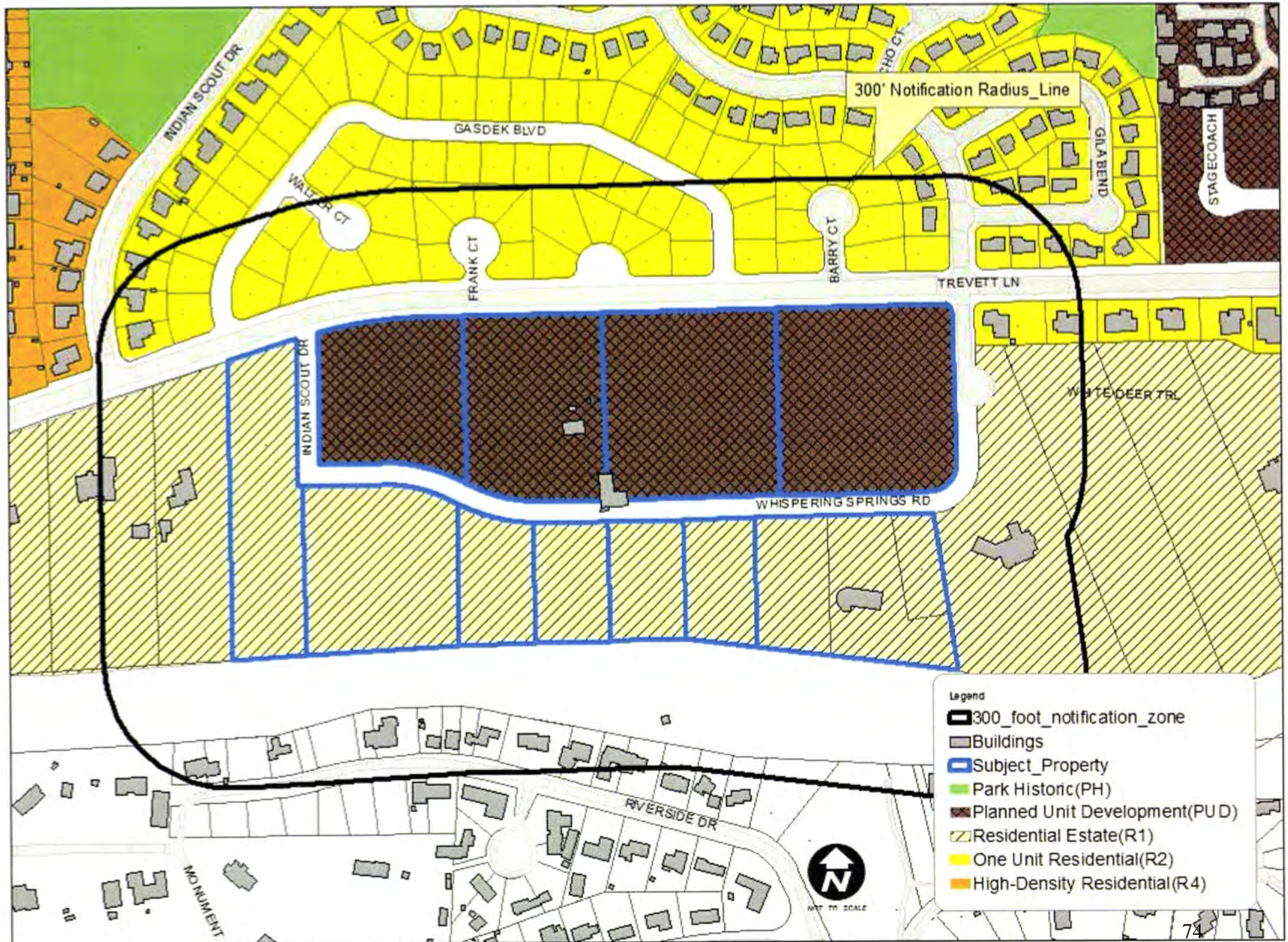



January 29, 2021

MEMO TO: J. Carter Napier, City Manager

FROM: Andrew Beamer, P.E., Public Services Director  
Scott R. Baxter, P.E., Associate Engineer

SUBJECT: Establish February 16, 2021, as the Public Hearing Date to Create Local Assessment District 158 – Coates Road Surfacing Improvements.

Meeting Type & Date

Regular Council Meeting  
February 2, 2021

Action type

Establish Public Hearing  
Minute Action

Recommendation

That Council, by minute action, establish February 16, 2020 as the Public Hearing date and 1<sup>st</sup> Reading to create Local Assessment District 158 – Coates Road Surfacing Improvements.

Summary

A property owner on Coates Road has requested that the City create a Local Assessment District (LAD) to upgrade Coates Road from a gravel road to a paved road. Coates Road is near the western edge of the City of Casper municipal boundary and runs south from State Highway 220 to the city limits, and beyond that in the jurisdiction of Natrona County.

In 2014, the City executed a memorandum of understanding with Natrona County for improvements on various road sections, including a maintenance agreement for this stretch of Coates Road. The subdivision (Skyline Ranches) served by Coates Road within the municipal boundary was originally developed under Natrona County jurisdiction in 1973 and was annexed sometime later into the City of Casper. There is no longer a singular developer, and the burden to make the improvements now lies with the property owners who access Coates Road. Engineering Staff invited the property owners to an informal public meeting on November 9, 2020. At least half of the property owners attended the meeting, and none of them was opposed to the LAD project or the estimated assessments.

The City of Casper Engineering Division has estimated the cost to make these improvements at \$187,440. This cost includes an engineering consultant to design and provide construction administration services, as well as the cost for a contractor to construct the improvements. The City can provide in-house engineering and construction services, the City and County would each pay for one-third of the total costs, and the property owners would be liable for one-third of the total cost. Engineering Staff is proposing that the LAD be established so that the assessments are

spread out over ten (10) equal annual installments at the interest rate of three percent (3%). If Council agrees to this proposal, the Engineering Division estimates the out-of-pocket expenses for all the property owners to be approximately \$62,480.

Wyoming Statutes (W.S.) govern the process for a city to follow to create a local improvement district. A city has the authority to provide for the making and maintenance of local improvements and to levy and collect a special assessment on the property specially benefited to pay all or part of the cost of the improvement. Casper Municipal Code refers to the local improvement process as “Local Assessment Districts (LADs).”

#### General Powers and Duties Overview:

The Casper City Council (Council) may order any improvement and determine its character, kind and extent. If the improvement is paving, it shall designate the kinds of pavement to be used. It shall provide for the maintenance of an improvement for a specified period not to exceed five (5) years and include the cost of that maintenance in the assessment for making the improvements. Council shall levy and collect an assessment upon all lots, parts of lots, and parcels of land, specially benefitted by the improvements, to defray all or any part of the cost and expense, and to determine which lots, parts of lots, and parcels of land are specially benefitted by the improvements and the amount each is benefitted.

#### Process

**Resolution of Intention to Create an LAD** – W.S. §§ 15-6-201 through 15-6-202. Any improvement may be initiated directly by Council by resolution declaring its intention to make improvements

**Notice by Publication and Mailing** - W.S. § 15-6-202(d) and (e). Fifteen (15) days prior to the public hearing, the resolution must be published at least once in the newspaper.

In addition to the publication, a copy of the resolution of intention shall be mailed, postage prepaid, at least fifteen (15) days prior to the hearing, to each legal owner of record of the property within the proposed district.

**Objections and Authority to Act** – W.S. §§ 15-6-203 & 204.

- Owners have fifteen (15) days from the publication to file with the city clerk their written objections to the proposed improvement.
- If protests are filed by the legal owners of record of more than one-half (1/2) of the area of the property subject to assessment, the proposed improvements within that district will usually be abandoned. However, W.S. §15-6-205 provides for an exception if the improvement proposed is to a street and not more than two (2) blocks remain unimproved in the street between improvements already made or proposed to be made; in such event, “the governing body on its own motion may cause the intervening or unimproved part to be improved. The improvement of that part shall not be stayed, defeated or prevented by any remonstrance or other objection, unless the governing body considers the remonstrance or objection proper to stay or prevent the improvement.”



**Public Hearing & Ordinance Ordering Improvement** – W.S. § 15-6-206. Upon the hearing of the resolution of intention, if Council decides to proceed with the improvement, it shall pass an ordinance. After Council passes the ordinance, the City Engineer shall prepare and file with the city clerk plans and specifications which shall show in detail the work to be done, the quantities of material to be handled, and the estimated cost of the improvements. Council shall approve the plans and specifications by motion or resolution.

The improvements may be made under contract, or as a part of a contract, publicly let by the city in the manner provided in this section and W.S. § 15-6-302 (Bidding Requirements), or the city may make the improvements with its own equipment, labor and materials, without contract, or any combination of methods may be followed.

Financial Consideration

For the LAD project, the City has budgeted \$67,000 from one-cent #16 funds for construction, Natrona County has budgeted \$67,000, and eighteen property owners would contribute an average of approximately \$3,722 each, thus the overall cost of the project, without profit, is budgeted at approximately \$200,000.

Natrona County has committed an additional \$110,000 for further extension of the road south of the City limits and will reimburse the City in full for those improvements.

Oversight/Project Responsibility

Scott R. Baxter, P.E., Associate Engineer

Attachments

None

January 20, 2021

MEMO TO: J. Carter Napier, City Manager *JCN*  
FROM: Liz Becher, Community Development Director *LB*  
SUBJECT: Consideration of an Ordinance Vacating a Portion of East 7<sup>th</sup> Street

**Meeting Type & Date:**

Regular Council Meeting, February 2, 2021

**Action Type:**

First Reading of an Ordinance, and Public Hearing

**Recommendation:**

That Council, by Ordinance, approve the vacation of East 7<sup>th</sup> Street between South Jackson Street and the public alley bisecting Blocks 62 and 63, Sheridan Heights Addition.

**Summary:**

The City has received a request to vacate an undeveloped portion of East 7<sup>th</sup> Street right-of-way located generally east of McKinley Street, and west of South Jackson Street. The Street was platted as part of the Sheridan Heights Addition in 1912, but has never been constructed because the steep topography of the site makes it impractical. Signed petitions have been provided from property owners owning a majority of the number and area of the properties within three hundred (300) feet of the vacation. In addition, all Casper utility providers have provided easement releases. Upon the vacation of the street, the City will reserve two utility easements within the former right-of-way. Pursuant to State law, the former street right-of-way will transfer automatically to the adjacent property owners upon vacation.

**Financial Considerations:**

Wyoming State Statute 15-4-305 states that the City may demand and receive the value of the land vacated as consideration for the vacation, if desired.

**Oversight/Project Responsibility:**

Craig Collins, AICP, City Planner – Community Development Department

**Attachments:**

Ordinance  
Exhibit A - Survey

ORDINANCE NO. 5-21

AN ORDINANCE APPROVING THE VACATION OF EAST  
7<sup>TH</sup> STREET BETWEEN SOUTH JACKSON STREET AND  
THE PUBLIC ALLEY BISECTING BLOCKS 62 AND 63,  
SHERIDAN HEIGHTS ADDITION

WHEREAS, the City of Casper has received a request to vacate East 7<sup>th</sup> Street between South Jackson Street, and the public alley bisecting Blocks 62 and 63 of the Sheridan Heights Addition, as described in a survey attached hereto as Exhibit A, which by reference herein is hereby incorporated as fully set forth; and,

WHEREAS, upon the vacation of East 7<sup>th</sup> Street, two (2) utility easements shall be reserved, as described in Exhibit A; and,

WHEREAS, a petition containing the signatures of a majority of the owners who own a majority of the property abutting the segments of the right-of-way proposed to be vacated and extending 300 feet in all directions from the street to be vacated has been submitted to the City as provided by W.S. §15-4-305; and,

WHEREAS, signed consents have been submitted from all Casper utility companies agreeing to release and abandon the existing utility easement associated with the seventy (70) foot wide street right-of-way being vacated; and,

WHEREAS, the City of Casper has determined that the described portion of the East 7<sup>th</sup> Street right-of-way can be vacated without adversely impacting utility services or traffic circulation in the surrounding area; and,

WHEREAS, it is the desire of the governing body of the City of Casper to approve said vacation.

NOW, THEREFORE, BE IT ORDAINED BY THE GOVERNING BODY OF THE CITY OF CASPER, WYOMING:

SECTION 1:

That the vacation of East 7<sup>th</sup> Street between South Jackson Street and the public alley bisecting Blocks 62 and 63, Sheridan Heights Addition, as described in Exhibit A, is hereby approved.

SECTION 2:

Two (2) utility easements are hereby reserved within the vacated East 7<sup>th</sup> Street right-of-way, as described in Exhibit A.

SECTION 3:

That the vacated portion of public right-of-way (alley) shall revert to the adjoining land owners, as provided by law.

SECTION 4:

This ordinance shall be in full force and effect from and after passage on three readings, and publication pursuant to law.

PASSED on 1st reading the \_\_\_\_\_ day of \_\_\_\_\_, 202\_\_.

PASSED on 2nd reading the \_\_\_\_\_ day of \_\_\_\_\_, 202\_\_.

PASSED, APPROVED, AND ADOPTED on 3rd and final reading the \_\_\_\_\_ day of \_\_\_\_\_, 202\_\_.

APPROVED AS TO FORM:

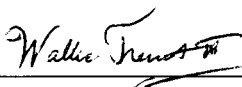
  
\_\_\_\_\_

ATTEST:

CITY OF CASPER, WYOMING  
A Municipal Corporation

\_\_\_\_\_  
Fleur Tremel  
City Clerk

\_\_\_\_\_  
Steven K. Freel  
Mayor

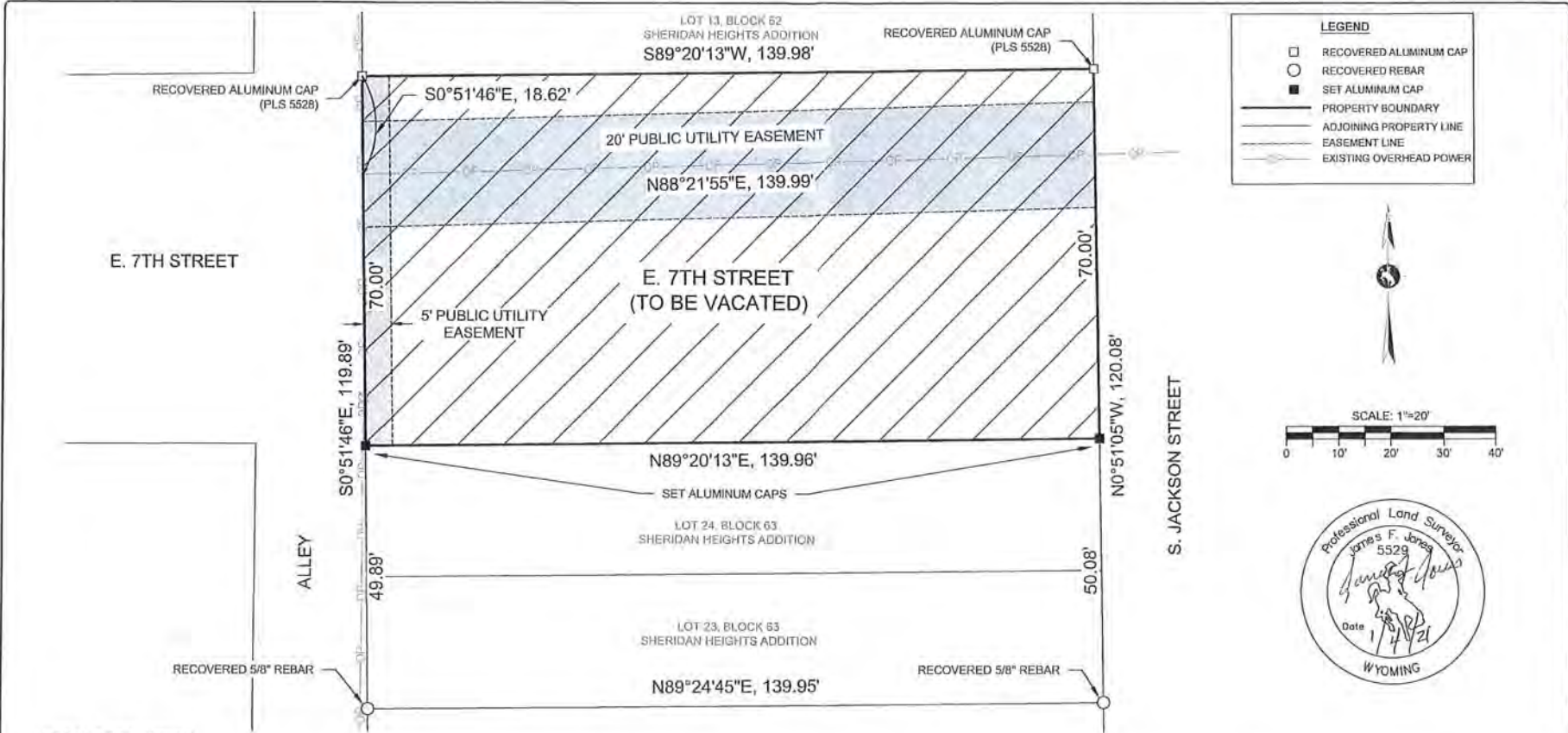

**LEGEND**

- RECOVERED ALUMINUM CAP
- RECOVERED REBAR
- SET ALUMINUM CAP
- PROPERTY BOUNDARY
- ADJOINING PROPERTY LINE
- EASEMENT LINE
- EXISTING OVERHEAD POWER

SCALE: 1"=20'

**LEGAL DESCRIPTION**

A PART OF EAST 7TH STREET BEING SOUTH OF BLOCK 62 AND NORTH OF BLOCK 63 AND BEING WEST OF SOUTH JACKSON STREET AND EAST OF SOUTH MCKINLEY STREET, SHERIDAN HEIGHTS ADDITION TO THE CITY OF CASPER, LOCATED IN THE SOUTHEAST QUARTER OF THE NORTHWEST QUARTER (SE1/4NW1/4) OF SECTION 10, TOWNSHIP 33 NORTH, RANGE 79 WEST, 6TH PRINCIPAL MERIDIAN, NATRONA COUNTY, WYOMING BEING MORE PARTICULARLY DESCRIBED BY METES AND BOUNDS AS FOLLOWS:

BEGINNING AT AN ALUMINUM CAP MONUMENTING THE SOUTHWEST CORNER OF LOT 13, BLOCK 62 OF THE SHERIDAN HEIGHTS ADDITION TO THE CITY OF CASPER; THENCE S.00°51'46"E., 70.00 FEET TO AN ALUMINUM CAP MONUMENTING THE NORTHWEST CORNER OF LOT 24, BLOCK 63 OF THE SHERIDAN HEIGHTS ADDITION TO THE CITY OF CASPER AND THE SOUTHWEST CORNER OF SAID PORTION OF EAST 7TH STREET; THENCE N.89°20'13"E., 139.95 FEET TO AN ALUMINUM CAP MONUMENTING THE NORTHEAST CORNER OF LOT 24, BLOCK 63 OF THE SHERIDAN HEIGHTS ADDITION TO THE CITY OF CASPER AND THE SOUTHWEST CORNER OF SAID PORTION OF EAST 7TH STREET; THENCE W.82°51'05"W., 79.99 FEET TO AN ALUMINUM CAP MONUMENTING THE SOUTHWEST CORNER OF LOT 13, BLOCK 62 OF THE SHERIDAN HEIGHTS ADDITION TO THE CITY OF CASPER AND THE NORTHEAST CORNER OF SAID PORTION OF EAST 7TH STREET; THENCE S.89°20'13"W., 139.98 FEET TO THE POINT OF BEGINNING. SAID PARCEL CONTAINING 9,798 SQUARE FEET MORE OR LESS.

**20' PUBLIC UTILITY EASEMENT DESCRIPTION**

A 20.00 FOOT WIDE PUBLIC UTILITY EASEMENT BEING A PORTION OF THE VACATED PORTION OF E. 7TH STREET BETWEEN S. MCKINLEY STREET AND S. JACKSON STREET, SITUATED IN THE SOUTHEAST QUARTER OF THE NORTHWEST QUARTER (SE1/4NW1/4) OF SECTION 10, TOWNSHIP 33 NORTH, RANGE 79 WEST, 6TH PRINCIPAL MERIDIAN, NATRONA COUNTY, WYOMING; SAID EASEMENT'S CENTERLINE BEING MORE PARTICULARLY DESCRIBED BY METES AND BOUNDS AS FOLLOWS:

COMMENCING AT AN ALUMINUM CAP MONUMENTING THE SOUTHWEST CORNER OF LOT 13, BLOCK 62 OF THE SHERIDAN HEIGHTS ADDITION TO THE CITY OF CASPER; THENCE S.00°51'46"E., 18.82 FEET TO THE POINT OF BEGINNING; THENCE N.88°21'55"E., ALONG THE CENTERLINE OF SAID PUBLIC UTILITY EASEMENT 139.99 FEET TO THE POINT OF TERMINATION, BEING LOCATED ON THE WEST LINE OF SOUTH JACKSON STREET. SAID PUBLIC UTILITY EASEMENT CONTAINS 2,800 SQUARE FEET MORE OR LESS.

**5' PUBLIC UTILITY EASEMENT DESCRIPTION**

A PUBLIC UTILITY EASEMENT BEING A PORTION OF THE VACATED EAST 7TH STREET R.O.W. BEING SOUTH OF BLOCK 62 AND NORTH OF BLOCK 63 AND BEING WEST OF SOUTH JACKSON STREET AND EAST OF SOUTH MCKINLEY STREET, SHERIDAN HEIGHTS ADDITION TO THE CITY OF CASPER, LOCATED IN THE SOUTHEAST QUARTER OF THE NORTHWEST QUARTER (SE1/4NW1/4) OF SECTION 10, TOWNSHIP 33 NORTH, RANGE 79 WEST, 6TH PRINCIPAL MERIDIAN, NATRONA COUNTY, WYOMING; SAID EASEMENT BEING FIVE (5) FEET WIDE AND BEING LOCATED ALONG THE WESTERN EDGE OF SAID VACATED PORTION OF EAST 7TH STREET'S R.O.W. SAID PUBLIC UTILITY EASEMENT CONTAINING 390 SQUARE FEET MORE OR LESS.

January 28, 2021

MEMO TO: His Honor the Mayor and Members of the City Council  
J. Carter Napier, City Manager JCN

FROM: John Henley, City Attorney JH

SUBJECT: An Ordinance Repealing Ordinance No. 54-00 as Codified by Article IV, Chapter 9.40 of the Casper Municipal Code and Creating a New Article IV of Chapter 9.40 of the Casper Municipal Code Titled "Sale of Nicotine Products"

**Meeting Type & Date**

Regular Council Meeting  
February 2, 2021

**Action type**

Public Hearing and First Reading.

**Recommendation**

Conduct the Public Hearing and determine how to proceed.

**Summary**

On July 1, 2020, Wyoming State Statutes §14-3-301 *et. seq.*, went into effect; these Statutes, which were passed by the Legislature and are the controlling law, prohibit the sale of nicotine products to persons under the age of twenty-one (21) years old, as well as the purchase, possession and use of nicotine products by persons under the age of twenty-one (21) years old.

At the January 12, 2021, Council Meeting, Council established the Public Hearing and First Reading for February 2, 2021, on a proposed ordinance to repeal and replace the current Ordinance. The current Ordinance is extremely outdated; it was adopted over twenty years ago, and does not address new types of vaping products, and similar products, that have since become available.

The proposed ordinance incorporates significantly the State Statutes, which recently became effective.

The proposed ordinance incorporates fines that are consistent with the fines passed by the State Legislature in 2020. As shown on page 2, the fine increases would affect businesses who violate the ordinance in terms of certain notices required to be posted by businesses, as well as employees who sell or deliver nicotine products to individuals under twenty-one years of age.

Fines for prohibited purchase, possession, and use by individuals under twenty-one years of age, would decrease significantly if the proposed ordinance is adopted. Additionally, if adopted, the proposed ordinance would provide individuals under twenty-one who are convicted or plead guilty to unlawful possession, purchase or use of nicotine products, a potential option to participate in community service to work off their fine at a rate of ten dollars (\$10.00) per hour of community service work performed (the current ordinance allows for credit of five dollars per

hour of community service work performed). The proposed ordinance would also allow for credit of ten dollars (\$10.00) per class hour attended, for persons who attend a nicotine cessation program.

**Fine Changes:**

*Under the current Ordinance a fine for a second or third violation can be imposed if a subsequent violation occurred within one year. The proposed ordinance would set the time period two years from the subsequent violation.*

- |   |          |                        |
|---|----------|------------------------|
| <b><u>Possession or use by persons under 21</u></b> |          |                        |
|   | Current  | Proposed               |
| 1 <sup>st</sup> offense, not <\$100.00              |          | \$25.00 per occurrence |
| 2 <sup>nd</sup> offense                             | \$200.00 |                        |
| 3 <sup>rd</sup> offense                             | \$500.00 |                        |
  
- |  |          |                        |
|--|----------|------------------------|
| <b><u>Purchase by persons under 21</u></b> |          |                        |
|  | Current  | Proposed               |
| 1 <sup>st</sup> offense not < \$100.00     |          | \$25.00 per occurrence |
| 2 <sup>nd</sup> offense                    | \$200.00 |                        |
| 3 <sup>rd</sup> offense                    | \$500.00 |                        |
  
- |  |          |          |
|--|----------|----------|
| <b><u>Prohibited sales and delivery:</u></b> |          |          |
|  | Current  | Proposed |
| 1 <sup>st</sup> offense, not < \$100.00      |          | \$250.00 |
| 2 <sup>nd</sup> offense                      | \$200.00 | \$500.00 |
| 3 <sup>rd</sup> offense                      | \$500.00 | \$750.00 |
  
- |  |                |          |
|--|----------------|----------|
| <b><u>Posted Notice Required, Location of Vending Machines:</u></b> (Each day of continued violation can be deemed a separate offense) |                |          |
|  | Current        | Proposed |
| 1 <sup>st</sup> offense  | \$100.00       | \$250.00 |
|  | per occurrence |          |
| 2 <sup>nd</sup> offense  |                | \$500.00 |
| 3 <sup>rd</sup> offense  |                | \$750.00 |

The current Ordinance includes affirmative defense provisions regarding parents or guardians who allow persons under eighteen years old to possess and use tobacco in the privacy of their own home, and under parent or guardian supervision. This provision is not included in the proposed ordinance.

The proposed ordinance introduces a new expungement provision (consistent with the State Statute) for persons under twenty-one years of age who plead guilty to, or are convicted of underage purchase, use, or possession of nicotine products; upon satisfaction of fines there is an automatic expungement of convictions from the court record after six months of entry of conviction.

A full copy of the proposed ordinance is attached to this Memo. The current Casper Code is published online by MuniCode and can be accessed by the public.

**Financial Considerations**

Minimal fine differences as set out above.

**Oversight/Project Responsibility**

Casper Police Department

City Attorney’s Office

**Attachments**

Proposed Ordinance

§14-3-301 *et. seq.*

Ordinance 54-00, basis for the current Code

ORDINANCE NO. 6-21

AN ORDINANCE REPEALING ORDINANCE NO. 54-00 AS CODIFIED BY ARTICLE IV, CHAPTER 9.40 OF THE CASPER MUNICIPAL CODE AND CREATING A NEW ARTICLE IV – OF CHAPTER 9.40 OF THE CASPER MUNICIPAL CODE TITLED “SALE OF NICOTINE PRODUCTS”.

WHEREAS, the governing body of the City of Casper has the authority granted by Wyoming State Statute §15-1-103(a)(xiii) and (xli) to adopt ordinances and resolutions necessary to protect the health, safety and welfare of the City and of its citizens; and,

WHEREAS, the governing body of the City of Casper may perform all acts in relation to the concerns of the City necessary to the exercise of its corporate powers; and,

WHEREAS, effective July 1, 2020, Wyoming Statutes §§ 14-3-301 *et. seq.*, prohibit the sale of nicotine and tobacco products to persons under twenty-one years old and the purchase, possession and use of and nicotine and tobacco products by persons under twenty-one years of age; and

WHEREAS, the Casper Municipal Code needs updated and modified from time to time; and,

WHEREAS, the governing body of the City of Casper desires to repeal Ordinance No. 54-00 as codified by Article IV, Chapter 9.40 of the Casper Municipal Code, and Create a new Article IV of Chapter 9.40 of the Casper Municipal Code titled “Sale of Nicotine Products” for the purpose of consistency between the Wyoming State Statutes and the Casper Municipal Code.

NOW, THEREFORE, BE IT ORDAINED BY THE GOVERNING BODY OF THE CITY OF CASPER, WYOMING:

Section 1: Chapter 9.40 Offenses by or Against Minors – Article IV – Sale of Tobacco (Sections 9.40.150 through 9.40.190), is repealed and to be replaced by Section 2 of this Ordinance.

Section 2: Chapter 9.40 Offenses by or Against Minors – Article IV titled “Sale of Nicotine Products” (Sections 9.40.150 through 9.40.190) is hereby created and shall be codified as follows:

9.40.150 - Definitions.

A. As used in this article:



1. "Tobacco products" means any substance containing tobacco leaf or any product made or derived from tobacco that contains nicotine including, but not limited to, cigarettes, cigars, pipe tobacco, snuff, chewing tobacco or dipping tobacco;
2. "Vending machine" means any mechanical, electric or electronic self-service device which, upon insertion of money, tokens, or any other form of payment, dispenses nicotine products;
3. "Retailer" means a business of any kind at a specific location that sells nicotine products to a user or consumer;
4. "Self service display" means any display of nicotine products that is located in an area where customers are permitted and where the nicotine products are readily accessible to a customer without the assistance of a salesperson;
5. "Electronic cigarette" means any device that can be used to deliver aerosolized or vaporized nicotine or synthetic nicotine material to the person using the device and includes any component, part and accessory of the device and any vapor material intended to be aerosolized or vaporized during the use of the device. "Electronic cigarette" includes, without limitation, any electronic cigar, electronic cigarillo, electronic pipe, electronic hooka, vapor pen and any similar product or device. "Electronic cigarette" does not include a battery or battery charger if sold separately from the electronic cigarette and does not include any product regulated as a drug or device by the United States food and drug administration under subchapter V of the Food, Drug and Cosmetic Act;
6. "Nicotine products" means tobacco products and electronic cigarettes;
7. "Vapor material" means any liquid solution or other material containing nicotine or synthetic nicotine that is depleted as an electronic cigarette is used. "Vapor material" includes liquid solution or other material containing nicotine or synthetic nicotine that is sold with or inside an electronic cigarette.

#### 9.40.160 – Prohibited sales or delivery

- A. No individual shall sell, offer for sale, give away or deliver nicotine products to any person under the age of twenty-one (21) years.
- B. Any individual violating subsection A. of this section is guilty of a misdemeanor punishable by a fine of not more than:
  1. Two hundred fifty dollars (\$250.00) for a first violation committed within a twenty-four (24) month period. The court may allow the defendant to perform community service or attend a tobacco or nicotine cessation program and be granted credit against his fine and court costs at the rate of ten dollars (\$10.00) for each hour of work performed or each hour of tobacco or nicotine cessation program attended;

2. Five hundred dollars (\$500.00) for a second violation committed within a twenty-four (24) month period, regardless of the locations where the violations occurred. The court may allow the defendant to perform community service or attend a tobacco or nicotine cessation program and be granted credit against his fine and court costs at the rate of ten dollars (\$10.00) for each hour of work performed or each hour of tobacco or nicotine cessation program attended;
  3. Seven hundred fifty dollars (\$750.00) for a third or subsequent violation committed within a twenty-four (24) month period, regardless of the locations where the violations occurred. The court may allow the defendant to perform community service and be granted credit against his fine and court costs at the rate of ten dollars (\$10.00) for each hour of work performed.
- C. No retailer shall sell, permit the sale, offer for sale, give away or deliver nicotine products to any person under the age of twenty-one (21) years.
- D. Any person violating subsection C. of this section is guilty of a misdemeanor punishable by a fine of not more than:
1. Two hundred fifty dollars (\$250.00) for a first violation committed within a twenty-four (24) month period;
  2. Five hundred dollars (\$500.00) for a second violation committed within a twenty-four (24) month period;
  3. Seven hundred fifty dollars (\$750.00) for a third or subsequent violation committed within a twenty- four (24) month period.
- E. Nothing in this Municipal Code Chapter shall modify or limit the provisions for injunctive relief pursuant to Wyoming Statutes §14-3-302 (e).
- F. It is an affirmative defense to a prosecution under subsections A. and C. of this section that, in the case of a sale, the person who sold the nicotine product was presented with, and reasonably relied upon, an identification card which identified the person buying or receiving the nicotine product as being over twenty-one (21) years of age.
- G. Notwithstanding the provisions of subsection D. of this section, no fine for a violation of subsection C. of this section shall be imposed for a first offense in a twenty-four (24) month period if the retailer can show it had:
1. Adopted and enforced a written policy against selling nicotine products to persons under the age of twenty-one (21) years;
  2. Informed its employees of the applicable laws regarding the sale of nicotine products to persons under the age of twenty-one (21) years;

3. Required employees to verify the age of nicotine product customers by way of photographic identification or by means of electronic transaction scan device; and
4. Established and imposed disciplinary sanctions for noncompliance.

9.40.170 Posted notice required; location of vending machines

A. Any person who sells nicotine products shall post signs informing the public of the age restrictions provided by this article at or near every display of nicotine products and on or upon every vending machine which offers nicotine products for sale. Each sign shall be plainly visible and shall contain a statement communicating that the sale of nicotine products to persons under twenty-one (21) years of age is prohibited by law. Any person who owns, operates or manages a business where nicotine products are offered for sale at retail and at which persons under the age of twenty-one (21) are allowed admission with or without an adult, shall maintain all nicotine products within the line of sight of a cashier or other employee or under the control of the cashier or other employee. For purposes of this subsection:

1. "Within the line of sight" means visible to a cashier or other employee while at the sales counter; and
2. "Under control" means protected by security, surveillance or detection methods.

B. No person shall sell or offer nicotine products:

1. Through a vending machine unless the vending machine is located in:
  - a. Businesses, factories, offices or other places not open to the general public;
  - b. Places to which persons under the age of twenty-one (21) years of age are not permitted access; or
  - c. Business premises where alcoholic or malt beverages are sold or dispensed and where entry by persons under twenty-one (21) years of age is prohibited.
2. Through a self service display except in:
  - a. A vending machine as permitted in paragraph 1. of this subsection; or
  - b. A business where entry by persons under twenty-one (21) years of age is prohibited.

C. Any person violating subsection A. or B. of this section is guilty of a misdemeanor punishable by a fine of not more than:

1. Two hundred fifty dollars (\$250.00) for a first violation committed within a twenty-four (24) month period;
2. Five hundred dollars (\$500.00) for a second violation committed within a twenty-four (24) month period;
3. Seven hundred fifty dollars (\$750.00) for a third or subsequent violation committed within a twenty- four (24) month period.

D. For purposes of subsection A. of this section, each day of continued violation under subsection A. or B. of this section shall be deemed a separate offense.

E. Nothing in this Municipal Code Chapter shall modify or limit the provisions for injunctive relief pursuant to Wyoming Statute §14-3-303(e).

9.40.180 Purchase by person under twenty-one years of age prohibited.

A. No person under the age of twenty-one (21) years shall purchase or attempt to purchase nicotine products, or misrepresent his identity or age, or use any false or altered identification for the purpose of purchasing or attempting to purchase nicotine products. A person shall not be arrested for an alleged violation of this subsection but shall be issued a citation as a charging document by a peace officer having probable cause to believe the person violated this subsection. An officer issuing a citation shall deposit one (1) copy of the citation with the court having jurisdiction over the alleged offense. Bond may be posted and forfeited for an offense charged under this section in an amount equal to the fine imposed by subsection B. of this section.

B. Any person violating subsection A. of this section is guilty of a misdemeanor punishable by a fine of twenty-five dollars (\$25.00).

C. In lieu of the fine under subsection B. of this section, the court may allow the defendant to perform community service or attend a tobacco or nicotine cessation program and be granted credit against his fine and court costs at the rate of ten dollars (\$10.00) for each hour of work performed or each hour of tobacco or nicotine cessation program attended.

D. No conviction under this section, whether by guilty plea, adjudication of guilt or forfeiture of bond shall be reported by the court to any law enforcement agency. Upon payment of the fine imposed by subsection B. of this section, a criminal conviction under this section shall be expunged by operation of law from all records of the court six (6)

months after the entry of conviction. For any person whose record of conviction was expunged under this subsection, the conviction is deemed not to have occurred and the individual may reply accordingly upon any inquiry in the matter. No expungement under this subsection shall be considered for purposes of any other law providing for expungement.

9.40.190 Possession or use by person under twenty-one years of age prohibited.

- A. It is unlawful for any person under the age of twenty-one (21) years to possess or use any nicotine products. A person shall not be arrested for an alleged violation of this subsection but shall be issued a citation as a charging document by a peace officer having probable cause to believe the person violated this subsection. An officer issuing a citation shall deposit one (1) copy of the citation with the court having jurisdiction over the alleged offense. Bond may be posted and forfeited for an offense charged under this section in an amount equal to the fine imposed by subsection B. of this section.
- B. Any person violating subsection A. of this section is guilty of a misdemeanor punishable by a fine of twenty-five dollars (\$25.00).
- C. In lieu of the fine under subsection B. of this section, the court may allow the defendant to perform community service or attend a tobacco or nicotine cessation program and be granted credit against his fine and court costs at the rate of ten dollars (\$10.00) for each hour of work performed or each hour of tobacco or nicotine cessation program attended.
- D. No conviction under this section, whether by guilty plea, adjudication of guilt or forfeiture of bond shall be reported by the court to any law enforcement agency. Upon payment of the fine imposed by subsection B. of this section, a criminal conviction under this section shall be expunged by operation of law from all records of the court six (6) months after the entry of conviction. For any person whose record of conviction was expunged under this subsection, the conviction is deemed not to have occurred and the individual may reply accordingly upon any inquiry in the matter. No expungement under this subsection shall be considered for purposes of any other law providing for expungement.

PASSED on 1<sup>st</sup> reading the \_\_\_\_ day of \_\_\_\_\_, 2021

PASSED on 2<sup>nd</sup> reading the \_\_\_\_ day of \_\_\_\_\_, 2021

PASSED, APPROVED, AND ADOPTED on third and final reading the \_\_\_\_\_ day of \_\_\_\_\_, 2021.

APPROVED AS TO FORM:

---

ATTEST:

---

Fleur Tremel  
City Clerk

CITY OF CASPER, WYOMING  
A Municipal Corporation

---

Steven K. Freel  
Mayor

 KeyCite Yellow Flag - Negative Treatment  
Proposed Legislation

West's Wyoming Statutes Annotated  
Title 14. Children (Refs & Annos)  
Chapter 3. Protection (Refs & Annos)  
Article 3. Sale of Nicotine Products

W.S.1977 § 14-3-301

## § 14-3-301. Definitions

Effective: July 1, 2020  
[Currentness](#)

(a) As used in this article:

(i) "Tobacco products" means any substance containing tobacco leaf or any product made or derived from tobacco that contains nicotine including, but not limited to, cigarettes, cigars, pipe tobacco, snuff, chewing tobacco or dipping tobacco;

(ii) "Vending machine" means any mechanical, electric or electronic self-service device which, upon insertion of money, tokens, or any other form of payment, dispenses nicotine products;

(iii) "Retailer" means a business of any kind at a specific location that sells nicotine products to a user or consumer;

(iv) "Self service display" means any display of nicotine products that is located in an area where customers are permitted and where the nicotine products are readily accessible to a customer without the assistance of a salesperson;

(v) "Electronic cigarette" means any device that can be used to deliver aerosolized or vaporized nicotine or synthetic nicotine material to the person using the device and includes any component, part and accessory of the device and any vapor material intended to be aerosolized or vaporized during the use of the device. "Electronic cigarette" includes, without limitation, any electronic cigar, electronic cigarillo, electronic pipe, electronic hooka, vapor pen and any similar product or device. "Electronic cigarette" does not include a battery or battery charger if sold separately from the electronic cigarette and does not include any product regulated as a drug or device by the United States food and drug administration under subchapter V of the Food, Drug and Cosmetic Act;

(vi) "Nicotine products" means tobacco products and electronic cigarettes;

(vii) "Vapor material" means any liquid solution or other material containing nicotine or synthetic nicotine that is depleted as an electronic cigarette is used. "Vapor material" includes liquid solution or other material containing nicotine or synthetic nicotine that is sold with or inside an electronic cigarette.

**Credits**

Laws 1991, ch. 76, § 1; Laws 2000, ch. 93, § 2, eff. July 1, 2000; Laws 2007, ch. 93, § 1, eff. July 1, 2007; Laws 2013, ch. 144, § 1, eff. March 13, 2013; Laws 2020, ch. 53, § 1, eff. July 1, 2020; Laws 2020, ch. 83, § 1, eff. July 1, 2020; Laws 2020, ch. 86, § 2, eff. July 1, 2020.

W. S. 1977 § 14-3-301, WY ST § 14-3-301

Current through the 2020 Budget Session of the Wyoming Legislature. Current through Chapters 1-3 of the 2020 Special Session of the Wyoming Legislature.

---

End of Document

© 2021 Thomson Reuters. No claim to original U.S. Government Works.



West's Wyoming Statutes Annotated  
Title 14. Children (Refs & Annos)  
Chapter 3. Protection (Refs & Annos)  
Article 3. Sale of Nicotine Products

W.S.1977 § 14-3-302

§ 14-3-302. Prohibited sales or delivery

Effective: July 1, 2020

[Currentness](#)

(a) No individual shall sell, offer for sale, give away or deliver nicotine products to any person under the age of twenty-one (21) years.

(b) Any individual violating [W.S. 14-3-309](#) or subsection (a) of this section is guilty of a misdemeanor punishable by a fine of not more than:

(i) Two hundred fifty dollars (\$250.00) for a first violation committed within a twenty-four (24) month period. The court may allow the defendant to perform community service or attend a tobacco or nicotine cessation program and be granted credit against his fine and court costs at the rate of ten dollars (\$10.00) for each hour of work performed or each hour of tobacco or nicotine cessation program attended;

(ii) Five hundred dollars (\$500.00) for a second violation committed within a twenty-four (24) month period, regardless of the locations where the violations occurred. The court may allow the defendant to perform community service or attend a tobacco or nicotine cessation program and be granted credit against his fine and court costs at the rate of ten dollars (\$10.00) for each hour of work performed or each hour of tobacco or nicotine cessation program attended;

(iii) Seven hundred fifty dollars (\$750.00) for a third or subsequent violation committed within a twenty- four (24) month period, regardless of the locations where the violations occurred. The court may allow the defendant to perform community service and be granted credit against his fine and court costs at the rate of five dollars (\$5.00) for each hour of work performed.

(c) No retailer shall sell, permit the sale, offer for sale, give away or deliver nicotine products to any person under the age of twenty-one (21) years.

(d) Any person violating subsection (c) of this section is guilty of a misdemeanor punishable by a fine of not more than:

(i) Two hundred fifty dollars (\$250.00) for a first violation committed within a twenty-four (24) month period;

(ii) Five hundred dollars (\$500.00) for a second violation committed within a twenty-four (24) month period;

(iii) Seven hundred fifty dollars (\$750.00) for a third or subsequent violation committed within a twenty- four (24) month period.

(e) In addition to the penalties under paragraph (d)(iii) of this section, any person violating subsection (c) of this section for a third or subsequent time within a two (2) year period may be subject to an injunction. The department of revenue or the district attorney of the county in which the offense occurred, may petition the district court for an injunction to prohibit the sale of nicotine products in the establishment where the violation occurred. If the court finds that the respondent in the action has violated the provisions of subsection (c) of this section for a third or subsequent time within a two (2) year period and may continue to violate such provisions, it may grant an injunction prohibiting the respondent from selling nicotine products in the establishment where the violation occurred for a period of not more than one hundred eighty (180) days. For the purposes of this subsection, multiple violations occurring before the petition for the injunction is filed shall be deemed part of the violation for which the injunction is sought. If the person against whom the injunction is sought operates multiple, geographically separate establishments, the injunction shall apply only to the establishment where the violation occurred. The injunction shall prohibit all sales of nicotine products in the establishment where the violation occurred, regardless of any change in ownership or management of the establishment that is not a bona fide, arms length transaction while the injunction is in effect.

(f) It is an affirmative defense to a prosecution under subsections (a) and (c) of this section that, in the case of a sale, the person who sold the nicotine product was presented with, and reasonably relied upon, an identification card which identified the person buying or receiving the nicotine product as being over twenty-one (21) years of age.

(g) Notwithstanding the provisions of subsection (d) of this section, no fine for a violation of subsection (c) of this section shall be imposed for a first offense in a twenty-four (24) month period if the retailer can show it had:

(i) Adopted and enforced a written policy against selling nicotine products to persons under the age of twenty-one (21) years;

(ii) Informed its employees of the applicable laws regarding the sale of nicotine products to persons under the age of twenty-one (21) years;

(iii) Required employees to verify the age of nicotine product customers by way of photographic identification or by means of electronic transaction scan device; and

(iv) Established and imposed disciplinary sanctions for noncompliance.

#### **Credits**

Laws 1991, ch. 76, § 1; Laws 2000, ch. 93, § 2, eff. July 1, 2000; Laws 2020, ch. 83, § 1, eff. July 1, 2020; Laws 2020, ch. 86, § 2, eff. July 1, 2020.

W. S. 1977 § 14-3-302, WY ST § 14-3-302

Current through the 2020 Budget Session of the Wyoming Legislature. Current through Chapters 1-3 of the 2020 Special Session of the Wyoming Legislature.



West's Wyoming Statutes Annotated  
Title 14. Children (Refs & Annos)  
Chapter 3. Protection (Refs & Annos)  
Article 3. Sale of Nicotine Products

W.S.1977 § 14-3-303

§ 14-3-303. Posted notice required; location of vending machines

Effective: July 1, 2020

[Currentness](#)

(a) Any person who sells nicotine products shall post signs informing the public of the age restrictions provided by this article at or near every display of nicotine products and on or upon every vending machine which offers nicotine products for sale. Each sign shall be plainly visible and shall contain a statement communicating that the sale of nicotine products to persons under twenty-one (21) years of age is prohibited by law. Any person who owns, operates or manages a business where nicotine products are offered for sale at retail and at which persons under the age of twenty-one (21) are allowed admission with or without an adult, shall maintain all nicotine products within the line of sight of a cashier or other employee or under the control of the cashier or other employee. For purposes of this subsection:

(i) "Within the line of sight" means visible to a cashier or other employee while at the sales counter; and

(ii) "Under control" means protected by security, surveillance or detection methods.

(b) No person shall sell or offer nicotine products:

(i) Through a vending machine unless the vending machine is located in:

(A) Businesses, factories, offices or other places not open to the general public;

(B) Places to which persons under the age of twenty-one (21) years of age are not permitted access; or

(C) Business premises where alcoholic or malt beverages are sold or dispensed and where entry by persons under twenty-one (21) years of age is prohibited.

(ii) Through a self service display except in:

(A) A vending machine as permitted in paragraph (i) of this subsection; or

(B) A business where entry by persons under twenty-one (21) years of age is prohibited.

(c) Any person violating subsection (a) or (b) of this section is guilty of a misdemeanor punishable by a fine of not more than:

(i) Two hundred fifty dollars (\$250.00) for a first violation committed within a twenty-four (24) month period;

(ii) Five hundred dollars (\$500.00) for a second violation committed within a twenty-four (24) month period;

(iii) Seven hundred fifty dollars (\$750.00) for a third or subsequent violation committed within a twenty-four (24) month period.

(d) For purposes of subsection (c) of this section, each day of continued violation under subsection (a) or (b) of this section shall be deemed a separate offense.

(e) In addition to the penalties under paragraph (c)(iii) of this section, any person violating subsection (a) or (b) of this section for a third or subsequent time within a two (2) year period may be subject to an injunction. The department or the district attorney of the county in which the offense occurred, may petition the district court for an injunction to prohibit the sale of nicotine products from the vending machines or the establishment where the violation occurred. If the court finds that the respondent in the action has violated the provisions of subsection (a) or (b) of this section for a third or subsequent time within a two (2) year period and may continue to violate such provisions, it may grant an injunction prohibiting the respondent from selling nicotine products from vending machines or from the establishment where the violation occurred for a period of not more than one hundred eighty (180) days. For the purposes of this subsection, multiple violations occurring before the petition for the injunction is filed shall be deemed part of the violation for which the injunction is sought. If the person against whom the injunction is sought operates multiple, geographically separate establishments or vending machines, the injunction shall apply only to the establishment where the violation occurred and to the vending machines resulting in the violation. The injunction shall prohibit all sales of nicotine products from the vending machines or the establishment involved in the violation, regardless of any change in ownership or management of the vending machines or the establishment that is not a bona fide, arms length transaction while the injunction is in effect.

#### **Credits**

Laws 1991, ch. 76, § 1; Laws 2000, ch. 93, § 2, eff. July 1, 2000; Laws 2007, ch. 93, § 1, eff. July 1, 2007; Laws 2020, ch. 83, § 1, eff. July 1, 2020.

W. S. 1977 § 14-3-303, WY ST § 14-3-303

Current through the 2020 Budget Session of the Wyoming Legislature. Current through Chapters 1-3 of the 2020 Special Session of the Wyoming Legislature.



West's Wyoming Statutes Annotated  
Title 14. Children (Refs & Annos)  
Chapter 3. Protection (Refs & Annos)  
Article 3. Sale of Nicotine Products

W.S.1977 § 14-3-304

## § 14-3-304. Purchase by person under twenty-one years of age prohibited

Effective: July 1, 2020

[Currentness](#)

(a) No person under the age of twenty-one (21) years shall purchase or attempt to purchase nicotine products, or misrepresent his identity or age, or use any false or altered identification for the purpose of purchasing or attempting to purchase nicotine products. A person shall not be arrested for an alleged violation of this subsection but shall be issued a citation as a charging document by a peace officer having probable cause to believe the person violated this subsection. An officer issuing a citation shall deposit one (1) copy of the citation with the court having jurisdiction over the alleged offense. Bond may be posted and forfeited for an offense charged under this section in an amount equal to the fine imposed by subsection (b) of this section.

(b) Any person violating subsection (a) of this section is guilty of a misdemeanor punishable by a fine of twenty-five dollars (\$25.00).

(i) to (iii) Repealed by [Laws 2020, ch. 83, § 2, eff. July 1, 2020](#).

(c) In lieu of the fine under subsection (b) of this section, the court may allow the defendant to perform community service or attend a tobacco or nicotine cessation program and be granted credit against his fine and court costs at the rate of ten dollars (\$10.00) for each hour of work performed or each hour of tobacco or nicotine cessation program attended.

(d) No conviction under this section, whether by guilty plea, adjudication of guilt or forfeiture of bond shall be reported by the court to any law enforcement agency. Upon payment of the fine imposed by subsection (b) of this section, a criminal conviction under this section shall be expunged by operation of law from all records of the court six (6) months after the entry of conviction. For any person whose record of conviction was expunged under this subsection, the conviction is deemed not to have occurred and the individual may reply accordingly upon any inquiry in the matter. No expungement under this subsection shall be considered for purposes of any other law providing for expungement.

### Credits

[Laws 1991, ch. 76, § 1](#); [Laws 2000, ch. 93, § 2, eff. July 1, 2000](#); [Laws 2020, ch. 83, §§ 1, 2, eff. July 1, 2020](#).

W. S. 1977 § 14-3-304, WY ST § 14-3-304

Current through the 2020 Budget Session of the Wyoming Legislature. Current through Chapters 1-3 of the 2020 Special Session of the Wyoming Legislature.

End of Document

© 2021 Thomson Reuters. No claim to original U.S. Government Works.

West's Wyoming Statutes Annotated  
Title 14. Children (Refs & Annos)  
Chapter 3. Protection (Refs & Annos)  
Article 3. Sale of Nicotine Products

W.S.1977 § 14-3-305

§ 14-3-305. Possession or use by person under twenty-one years of age prohibited

Effective: July 1, 2020

Currentness

(a) It is unlawful for any person under the age of twenty-one (21) years to possess or use any nicotine products. A person shall not be arrested for an alleged violation of this subsection but shall be issued a citation as a charging document by a peace officer having probable cause to believe the person violated this subsection. An officer issuing a citation shall deposit one (1) copy of the citation with the court having jurisdiction over the alleged offense. Bond may be posted and forfeited for an offense charged under this section in an amount equal to the fine imposed by subsection (b) of this section.

(b) Any person violating subsection (a) of this section is guilty of a misdemeanor punishable by a fine of twenty-five dollars (\$25.00).

(i) to (iii) Repealed by Laws 2020, ch. 83, § 2, eff. July 1, 2020.

(c) Repealed by Laws 2000, ch. 93, § 4.

(d) In lieu of the fine under subsection (b) of this section, the court may allow the defendant to perform community service or attend a tobacco or nicotine cessation program and be granted credit against his fine and court costs at the rate of ten dollars (\$10.00) for each hour of work performed or each hour of tobacco or nicotine cessation program attended.

(e) No conviction under this section, whether by guilty plea, adjudication of guilt or forfeiture of bond shall be reported by the court to any law enforcement agency. Upon payment of the fine imposed by subsection (b) of this section, a criminal conviction under this section shall be expunged by operation of law from all records of the court six (6) months after the entry of conviction. For any person whose record of conviction was expunged under this subsection, the conviction is deemed not to have occurred and the individual may reply accordingly upon any inquiry in the matter. No expungement under this subsection shall be considered for purposes of any other law providing for expungement.

**Credits**

Laws 1991, ch. 76, § 1; Laws 2000, ch. 93, §§ 2, 4, eff. July 1, 2000; Laws 2020, ch. 83, §§ 1, 2, eff. July 1, 2020.

W. S. 1977 § 14-3-305, WY ST § 14-3-305

Current through the 2020 Budget Session of the Wyoming Legislature. Current through Chapters 1-3 of the 2020 Special Session of the Wyoming Legislature.

End of Document

© 2021 Thomson Reuters. No claim to original U.S. Government Works.



West's Wyoming Statutes Annotated  
Title 14. Children (Refs & Annos)  
Chapter 3. Protection (Refs & Annos)  
Article 3. Sale of Tobacco

W.S.1977 § 14-3-306

§ 14-3-306. Teen court jurisdiction

Currentness

The teen court program authorized under W.S. 7-13-1203 may have jurisdiction over any offense committed by a minor under this article.

**Credits**

Laws 2000, ch. 93, § 1, eff. July 1, 2000.

W. S. 1977 § 14-3-306, WY ST § 14-3-306

Current through the 2020 Budget Session of the Wyoming Legislature. Current through Chapters 1-3 of the 2020 Special Session of the Wyoming Legislature.

---

End of Document

© 2021 Thomson Reuters. No claim to original U.S. Government Works.

West's Wyoming Statutes Annotated  
Title 14. Children (Refs & Annos)  
Chapter 3. Protection (Refs & Annos)  
Article 3. Sale of Nicotine Products

W.S.1977 § 14-3-307

## § 14-3-307. Compliance inspections

Effective: July 1, 2020

[Currentness](#)

- (a) The department of health, working with local law enforcement agencies and other local individuals and organizations at the discretion of the department, shall be the lead agency to ensure compliance with this article.
- (b) The department of health shall develop strategies to coordinate and support local law enforcement efforts to enforce all state statutes relating to the prohibition of the sale of nicotine products to persons under twenty-one (21) years of age.
- (c) The department shall have discretion to:
- (i) Work with each local law enforcement agency; and
  - (ii) Coordinate local enforcement efforts that appropriately reflect the needs of the community.
- (d) To coordinate the enforcement of state statutes relating to the prohibition of the sale of nicotine products to persons under twenty-one (21) years of age and to comply with applicable federal law, the department of health shall have authority to contract with or provide grants to local law enforcement agencies or other local individuals or entities having the appropriate level of enforcement authority on the local level to conduct random, unannounced inspections at retail locations where nicotine products are sold. The local law enforcement agencies or other local individuals or entities authorized to conduct inspections shall be permitted to use minors and persons under twenty-one (21) years of age subject to the following:
- (i) Prior to the inspection, the local law enforcement agency or other authorized individual or entity shall obtain the written consent of the person being used in the inspection or if using a minor, the written consent of the minor's parents or guardian shall be obtained prior to the minor participating in an inspection. The written consent required under this paragraph shall include a notification that testimony in a subsequent court proceeding may be required;
  - (ii) Any person under twenty-one (21) years of age participating in an inspection shall, if questioned, state his true age and that he is less than twenty-one (21) years of age;
  - (iii) The appearance of a person under twenty-one (21) years of age shall not be altered to make him appear to be twenty-one (21) years of age or older;

- (iv) Neither a minor nor his parents or guardians shall be coerced into participating in such inspections;
  - (v) The person conducting the inspection shall photograph the participant immediately before the inspection and any photographs taken of the participant shall be retained by the person conducting the inspection;
  - (vi) Any participant in an inspection under this section shall be granted immunity from prosecution under W.S. 14-3-304 or 14-3-305.
- (e) The person conducting an inspection under this section shall:
- (i) Remain within sight or sound of the participant attempting to make the purchase;
  - (ii) Immediately inform in writing a representative or agent of the business establishment that an inspection has been performed and the results of the inspection;
  - (iii) Within two (2) days, prepare a report of the inspection containing:
    - (A) The name of the person who supervised the inspection;
    - (B) The age and date of birth of the participant who assisted in the inspection;
    - (C) The name and position of the person from whom the participant attempted to purchase nicotine products;
    - (D) The name and address of the establishment inspected;
    - (E) The date and time of the inspection; and
    - (F) The results of the inspection, including whether the inspection resulted in the sale or distribution of, or offering for sale, nicotine products to a person under twenty-one (21) years of age.
  - (iv) Immediately upon completion of the report required under this subsection, provide a copy of the report to a representative or agent of the business establishment that was inspected;
  - (v) Request a law enforcement officer to issue a citation for any illegal acts relating to providing nicotine products to persons under twenty-one (21) years of age during the inspection.

**Credits**

Laws 2000, ch. 93, § 1, eff. July 1, 2000; Laws 2020, ch. 83, § 1, eff. July 1, 2020.

W. S. 1977 § 14-3-307, WY ST § 14-3-307

Current through the 2020 Budget Session of the Wyoming Legislature. Current through Chapters 1-3 of the 2020 Special Session of the Wyoming Legislature.

---

End of Document

© 2021 Thomson Reuters. No claim to original U.S. Government Works.



West's Wyoming Statutes Annotated  
Title 14. Children (Refs & Annos)  
Chapter 3. Protection (Refs & Annos)  
Article 3. Sale of Nicotine Products

W.S.1977 § 14-3-308

§ 14-3-308. Further regulation by local ordinance

Effective: July 1, 2020

[Currentness](#)

(a) Except as specified under subsection (b) of this section, this article shall not be construed to prohibit the imposition by local law or ordinance of further regulation or prohibition upon the sale, use and possession of nicotine products to any person under twenty-one (21) years of age, but the governmental entity shall not permit or authorize the sale, use or possession of nicotine products to any person under twenty-one (21) years of age in violation of this article.

(b) No governmental entity shall enact any law or ordinance which changes the standards provided by [W.S. 14-3-302\(a\)](#) and [\(c\)](#), [14-3-303\(a\)](#), [14-3-304\(a\)](#) and [14-3-305\(a\)](#).

(c) The governmental entity may require that sellers of nicotine products obtain a license to sell nicotine products and may deny or revoke the license in the case of reported violations of [W.S. 14-3-302](#) or similar local ordinance.

**Credits**

Laws 1991, ch. 76, § 1. Renumbered from § 14-3-306 by Laws 2000, ch. 93, § 3, eff. July 1, 2000; Laws 2004, ch. 130, § 1, eff. March 19, 2004; Laws 2020, ch. 83, § 1, eff. July 1, 2020.

W. S. 1977 § 14-3-308, WY ST § 14-3-308

Current through the 2020 Budget Session of the Wyoming Legislature. Current through Chapters 1-3 of the 2020 Special Session of the Wyoming Legislature.

West's Wyoming Statutes Annotated  
Title 14. Children (Refs & Annos)  
Chapter 3. Protection (Refs & Annos)  
Article 3. Sale of Nicotine Products

W.S.1977 § 14-3-309

§ 14-3-309. Regulation of mail order and internet  
purchases and sales; proof of age; penalties

Effective: July 1, 2020

[Currentness](#)

(a) No person shall sell at retail or wholesale any nicotine product through the internet or any other remote sales method to any person in this state, other than a vendor licensed under [W.S. 39-15-106](#), unless the seller performs an age verification on the purchaser through an independent third party age verification service. The age verification service utilized shall compare information available from public records to the personal information entered by the purchaser during the ordering process to establish that the purchaser is twenty-one (21) years of age or older.

(b) No person shall sell at retail or wholesale any nicotine product through the internet or any other remote sales method to any person in this state, other than a vendor licensed under [W.S. 39-15-106](#), unless the seller uses a method of mailing or shipping that, upon delivery, requires the signature of a person at least twenty-one (21) years of age before the nicotine product will be released for delivery.

(c) The provisions of subsections (a) and (b) of this section shall not apply if the seller employs one (1) of the following protections to ensure age verification:

(i) The purchaser is required to create an online profile or account with personal information verifying that the purchaser is at least twenty-one (21) years of age including, but not limited to, the purchaser's name, address and a valid phone number, if that personal information is verified by the seller through publicly available records and delivery is made to the same name and address; or

(ii) The purchaser is required to upload a copy of the purchaser's government issued identification and a current photograph of the purchaser verifying that the purchaser is at least twenty-one (21) years of age and delivery is made to the same name on the identification provided.

(d) Any person violating subsection (a) or (b) of this section is guilty of a misdemeanor punishable as provided in [W.S. 14-3-302\(b\)](#).

**Credits**

Laws 2020, ch. 86, § 1, eff. July 1, 2020.

W. S. 1977 § 14-3-309, WY ST § 14-3-309

Current through the 2020 Budget Session of the Wyoming Legislature. Current through Chapters 1-3 of the 2020 Special Session of the Wyoming Legislature.

---

End of Document

© 2021 Thomson Reuters. No claim to original U.S. Government Works.

ORDINANCE NO. 54-00

AN ORDINANCE CREATING ARTICLE IV OF  
CHAPTER 9.40 OF THE CASPER MUNICIPAL CODE,  
PERTAINING TO OFFENSES BY OR AGAINST  
MINORS.

SECTION 1:

Article IV of Chapter 9.40 of the Casper Municipal Code is hereby created to read as follows:

Article IV  
Sale of Tobacco

9.40.150 Definitions.

- A. "Tobacco products" means any substance containing tobacco leaf, including, but not limited to, cigarettes, cigars, pipe tobacco, snuff, chewing tobacco or dipping tobacco.
- B. "Vending machine" means any mechanical, electric or electronic self-service device which, upon insertion of money, tokens or any other form of payment, dispenses tobacco products.

9.40.160 Prohibited sales or delivery.

- A. No person shall sell, offer for sale, give away or deliver tobacco products to any person under the age of eighteen (18) years. Tobacco products shall be, to the extent possible, kept behind a counter or otherwise made inaccessible to purchasers of the tobacco product, and control and access to the tobacco product in the business establishment shall be maintained by the retailer, his agent or employee.
- B. Any person violating subsection (a) of this section is guilty of a misdemeanor punishable by a fine of not less than one hundred dollars (\$100) for the first offense; two hundred dollars (\$200) for the second offense in any twelve (12) month period; and, five hundred dollars (\$500) for third and subsequent offenses in any twelve (12) month period.
- C. It is an affirmative defense to a prosecution under subsection (a) of this section that:
  - 1. In the case of a sale, the person who sold the tobacco product was presented with, and reasonably relied upon, an identification card which identified the person buying or receiving the tobacco product as being over eighteen (18) years of age; or
  - 2. The tobacco product was given or delivered to the person under eighteen (18) years of age by his parent or guardian and the tobacco product was given or delivered to the person for use in the privacy of his parent's or guardian's home or under the direct supervision of the parent or guardian.

9.40.170 Posted notice required; location of vending machines.

- A. Any person who sells tobacco products shall post signs informing the public of the age restrictions provided by this article at or near every display of tobacco products and on or upon every vending machine which offers tobacco products for sale. Each sign shall be plainly visible and shall contain a statement communicating that the sale of tobacco products to persons under eighteen (18) years of age is prohibited by law.
- B. No person shall sell or offer tobacco products through a vending machine unless the vending machine is located in:
  - 1. Businesses, factories, offices or other places not open to the general public;



- 2. Places to which persons under the age of eighteen (18) years of age are not permitted access; or
  - 3. Business premises where alcoholic or malt beverages are sold or dispensed and where entry by persons under eighteen (18) years of age is prohibited.
- C. Any person violating subsection (a) or (b) of this section is guilty of a misdemeanor punishable by a fine of not more than one hundred dollars (\$100). Each day of continued violation shall be deemed a separate offense.

9.40.180 Purchase by minors prohibited.

- A. No person under the age of eighteen (18) years shall purchase tobacco products, or misrepresent his identity or age, or use any false or altered identification for the purpose of purchasing tobacco products.
- B. Any person violating subsection (a) of this section is guilty of a misdemeanor punishable by a fine of not less than one hundred dollars (\$100) for the first offense; two hundred dollars (\$200) for the second offense in any twelve (12) month period; and, five hundred dollars (\$500) for third and subsequent offenses in any twelve (12) month period. Upon a conviction for violation of subsection (a) of this section, the court may allow the defendant to perform community service and be granted credit against his fine and court costs at the rate of five dollars (\$5.00) for each hour of work performed.

9.40.190 Possession or use by minors prohibited.

- A. It is unlawful for any person under the age of eighteen (18) years to possess or use any tobacco products.
- B. Any person violating subsection (a) of this section is guilty of a misdemeanor punishable by a fine of not less than one hundred dollars (\$100) for the first offense; two hundred dollars (\$200) for the second offense in any twelve (12) month period; and, five hundred dollars (\$500) for third and subsequent offenses in any twelve (12) month period. Upon a conviction for violation of subsection (a) of this section, the court may allow the defendant to perform community service and be granted credit against his fine and court costs at the rate of five dollars (\$5.00) for each hour of work performed.
- C. It is an affirmative defense to a prosecution under subsection (a) of this section that the defendant possessed or used the tobacco product in the home of, or under the direct supervision of, a parent or guardian.

**SECTION 2:**

This ordinance shall be in full force and effect from and after passage on three readings and publication.

PASSED on first reading the 21st day of November, 2000.

PASSED on second reading the 4th day of December, 2000.

PASSED, APPROVED, AND ADOPTED on third and final reading the 19<sup>th</sup> day of December, 2000.

ATTEST:

  
 \_\_\_\_\_  
 V. H. McDonald  
 City Clerk

CITY OF CASPER, WYOMING  
 A Municipal Corporation

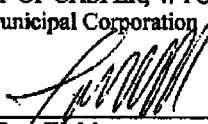
  
 \_\_\_\_\_  
 Dr. Tom Walsh  
 Mayor

January 18, 2021

**MEMO TO:** J. Carter Napier, City Manager *JCN*

**FROM:** Fleur Tremel, Assistant to the City Manager/City Clerk *FT*  
Carla Mills-Laatsch, Licensing Specialist *CM*

**SUBJECT:** Public Hearing for a New Restaurant Liquor License No. 43 for Ludovico, d/b/a Ludovico Located at 1301 Wilkins Circle

Meeting Type & Date

Regular Council Meeting  
February 2, 2021

Action type

Public Hearing  
Minute Action

Recommendation

That Council, by minute action, consider the application for a new restaurant liquor license No. 43 for Ludovico, d/b/a Ludovico located at 1301 Wilkins Circle.

Summary

An application has been received requesting a new restaurant liquor license No. 43 for Ludovico, d/b/a Ludovico located at 1301 Wilkins Circle. This address is located inside Gruner Brother Brewing. Gruner Brothers currently holds a Microbrewery license with the City of Casper. Municipal Code 5.08.100 (B) (3) allows for a dual holding of a microbrewery license and a restaurant license.

Ludovico had a restaurant liquor license at 3095 Talon Suite 100. This location stopped serving alcohol June of 2020 and the license was returned to the City of Casper. If approved, this license will be issued on February 3, 2021.

As required by Municipal Code 05.08.070, a notice was published in a local newspaper once a week for two consecutive weeks. As required by State Statute 12-4-104(a) it is being advertised on the City's website ([www.casperwy.gov](http://www.casperwy.gov)).

Financial Considerations

No Financial Considerations

Oversight/Project Responsibility

Carla Mills-Laatsch, Licensing Specialist

Attachments

Copy of Application

Affidavit of Website Publication

Copy of letter from Gruner Brothers

# NEW OR TRANSFER LIQUOR LICENSE OR PERMIT APPLICATION

FOR LIQUOR DIVISION USE ONLY		
Customer #:		
Trf from:		
Reviewer:	Initials	Date
Agent:		/ /
Chief:		/ /

**To be completed by City/County Clerk**

Local License #: Restaurant

License Fees Annual Fee: \$ 1500.00 Date filed with clerk: 1 / 8 / 2021

Prorated Fee: \$ 233.70 Advertising Dates: (2 Weeks) Jan 22, 21 & Jan 24, 2021

Transfer Fee: \$ \_\_\_\_\_ Hearing Date: 02 / 02 / 2021

Publishing Fee: \$ \_\_\_\_\_

Publishing Fee Direct Billed to Applicant:

License Term: 02 / 03 / 2021 Through 03 / 31 / 2021

Month Day Year Month Day Year

**LICENSING AUTHORITY:** Begin publishing promptly. As W.S. 12-4-104(d) specifies: **NO LICENSING AUTHORITY SHALL APPROVE OR DENY THE APPLICATION UNTIL THE LIQUOR DIVISION HAS CERTIFIED THE APPLICATION IS COMPLETE.**

Applicant: LUDDVICO

Trade/Business Name (dba): LUDDVICO

Building to be licensed/Building Address: 1301 WILKINS CIRCLE  
Number & Street

CASPER WY NATRONA  
City State Zip County

Mailing Address: 1301 Wilkins Circle  
Number & Street or P.O. Box

CASPER WY 82601  
City State Zip

Business Telephone Number: (307) 337-1979 Fax Number: ( )

E-Mail Address: Marketing @ FIREHOUSEPIZZAWOODFIREW.COM

Brief legal description and the zoning of the licensed building or site for licensed building: W.S. 12-4-102 (a) (vi)  
NORTH PLATE IND PK LOT 9 Commercial

FILING FOR	FILING IN (CHOOSE ONLY ONE)	FILING AS (CHOOSE ONLY ONE)
<input checked="" type="checkbox"/> NEW LICENSE	<input checked="" type="checkbox"/> CITY OF: <u>CASPER</u>	<input type="checkbox"/> INDIVIDUAL
<input type="checkbox"/> TRANSFER OF LOCATION	<input checked="" type="checkbox"/> COUNTY OF: <u>NATRONA</u>	<input type="checkbox"/> PARTNERSHIP
<input type="checkbox"/> TRANSFER OWNERSHIP	<input type="checkbox"/> ASSIGNMENT LETTER ATTACHED	<input type="checkbox"/> LP/LLP
FORMERLY HELD BY: _____		<input type="checkbox"/> LLC
		<input checked="" type="checkbox"/> CORPORATION
		<input type="checkbox"/> LTD PARTNERSHIP
		<input type="checkbox"/> ORGANIZATION
		<input type="checkbox"/> OTHER

**TYPE OF LICENSE OR PERMIT (CHOOSE ONLY ONE)**

<input type="checkbox"/> RETAIL LIQUOR LICENSE ON-PREMISE ONLY (BAR)	<input checked="" type="checkbox"/> RESTAURANT LIQUOR LICENSE	<input type="checkbox"/> MICROBREWERY
<input type="checkbox"/> OFF-PREMISE ONLY (PACKAGE STORE)	<input type="checkbox"/> RESORT LIQUOR LICENSE	<input type="checkbox"/> WINERY
<input type="checkbox"/> COMBINATION ON/OFF PREMISE (BOTH BAR & PACKAGE STORE)	<input type="checkbox"/> BAR AND GRILL	<input type="checkbox"/> DISTILLERY SATELLITE
	LIMITED RETAIL (CLUB)	<input type="checkbox"/> WINERY SATELLITE
	<input type="checkbox"/> VETERANS CLUB	<input type="checkbox"/> COUNTY RETAIL or SPECIAL MALT BEVERAGE PERMIT
	<input type="checkbox"/> FRATERNAL CLUB	<b>SPECIAL DESIGNATIONS</b>
	<input type="checkbox"/> GOLF CLUB	<input type="checkbox"/> CONVENTION FACILITY
	<input type="checkbox"/> SOCIAL CLUB	<input type="checkbox"/> CIVIC CENTER/EVENT CENTER/ PUBLIC AUDITORIUM
		<input type="checkbox"/> GOLF CLUB
		<input type="checkbox"/> GUEST RANCH
		<input type="checkbox"/> RESORT

To Assist the Liquor Division with scheduling inspections: **WHEN DO YOU OPERATE?**

FULL TIME (e.g. Jan through Dec)  SEASONAL/PART-TIME  NON-OPERATIONAL/PARKED

(specify months of operation) DAYS OF WEEK (e.g. Mon through Sat) HOURS OF OPERATION (e.g. 10a - 2a)

from JAN to DEC from MON to SUN from 11 AM to 9 PM

**ALL APPLICANTS MUST COMPLETE QUESTIONS 1-6**

1. BUILDING OWNERSHIP: Does the applicant? W.S. 12-4-103 (a) (iii)
- (1) OWN the licensed building?  YES (own)
- (2) LEASE the licensed building? (Lease must be through the term of the liquor license)  YES (lease)
- If Yes, please submit a copy of the lease and indicate:
- (A) When the lease expires, located on page 3 paragraph 2 of lease.
- (B) Where the Sales provision for alcoholic or malt beverages is located, on page 3 paragraph 3 of lease. (MUST contain a provision for SALE OF ALCOHOLIC or MALT BEVERAGES.)

2. To operate your liquor business, have you assigned, leased, transferred or contracted with any other person (entity) to operate and assert total or partial control of the license and the licensed building? W.S. 12-4-601 (b)  YES  NO
3. Does any manufacturer, brewer, rectifier, wholesaler, or through a subsidiary affiliate, officer, director or member of any such firm: W.S. 12-5-401, 12-5-402, 12-5-403
- (a) Hold any interest in the license applied for?  YES  NO
- (b) Furnish by way of loan or any other money or financial assistance for purposes hereof in your business?  YES  NO
- (c) Furnish, give, rent or loan any equipment, fixtures, interior decorations or signs other than standard brewery or manufacturer's signs?  YES  NO
- (d) If you answered YES to any of the above, explain fully and submit any documents in connection there within:

4. Does the applicant have any interest or intent to acquire an interest in any other liquor license issued by this licensing authority? W.S. 12-4-103 (b)  YES  NO
- If "YES", explain: \_\_\_\_\_

5. If applicant is filing as an **Individual, Partnership or Club**: W.S. 12-4-102 (a) (ii) & (iii)

Each individual, partner or club officer must complete the box below.

True and Correct Name	Date of Birth	Residence Address No. & Street City, State & Zip <i>DO NOT LIST PO BOXES</i>	Residence Phone Number	Have you been a DOMICILED resident for at least 1 year and not claimed residence in any other state in the last year?	Have you been Convicted of a Felony Violation?	Have you been Convicted of a Violation Relating to Alcoholic Liquor or Malt Beverages?
				YES <input type="checkbox"/> NO <input type="checkbox"/>	YES <input type="checkbox"/> NO <input type="checkbox"/>	YES <input type="checkbox"/> NO <input type="checkbox"/>
				YES <input type="checkbox"/> NO <input type="checkbox"/>	YES <input type="checkbox"/> NO <input type="checkbox"/>	YES <input type="checkbox"/> NO <input type="checkbox"/>
				YES <input type="checkbox"/> NO <input type="checkbox"/>	YES <input type="checkbox"/> NO <input type="checkbox"/>	YES <input type="checkbox"/> NO <input type="checkbox"/>
				YES <input type="checkbox"/> NO <input type="checkbox"/>	YES <input type="checkbox"/> NO <input type="checkbox"/>	YES <input type="checkbox"/> NO <input type="checkbox"/>
				YES <input type="checkbox"/> NO <input type="checkbox"/>	YES <input type="checkbox"/> NO <input type="checkbox"/>	YES <input type="checkbox"/> NO <input type="checkbox"/>
				YES <input type="checkbox"/> NO <input type="checkbox"/>	YES <input type="checkbox"/> NO <input type="checkbox"/>	YES <input type="checkbox"/> NO <input type="checkbox"/>

(If more information is required, list on a separate piece of paper and attach to this application.)

6. If the applicant is a **Corporation, Limited Liability Company, Limited Liability Partnership or Limited Partnership**: W.S. 12-4-102 (a) (iv) & (v)

Each stockholder holding, either jointly or severally, ten percent (10%) or more of the outstanding and issued capital stock of the corporation, limited liability company, limited liability partnership, or limited partnership, and every officer, and every director must complete the box below.

True and Correct Name	Date of Birth	Residence Address No. & Street City, State & Zip <i>DO NOT LIST PO BOXES</i>	Residence Phone Number	No. of Years in Corp or LLC	% of Corporate Stock Held	Have you been Convicted of a Felony Violation?	Have you been Convicted of a Violation Relating to Alcoholic Liquor or Malt Beverages?
ALLEN HANSON						YES <input type="checkbox"/> NO <input checked="" type="checkbox"/>	YES <input type="checkbox"/> NO <input checked="" type="checkbox"/>
NICOLE BOITZ						YES <input type="checkbox"/> NO <input checked="" type="checkbox"/>	YES <input type="checkbox"/> NO <input checked="" type="checkbox"/>
JUSTIN BOITZ						YES <input type="checkbox"/> NO <input checked="" type="checkbox"/>	YES <input type="checkbox"/> NO <input checked="" type="checkbox"/>
						YES <input type="checkbox"/> NO <input type="checkbox"/>	YES <input type="checkbox"/> NO <input type="checkbox"/>
						YES <input type="checkbox"/> NO <input type="checkbox"/>	YES <input type="checkbox"/> NO <input type="checkbox"/>
						YES <input type="checkbox"/> NO <input type="checkbox"/>	YES <input type="checkbox"/> NO <input type="checkbox"/>

(If more information is required, list on a separate piece of paper and attach to this application.)

**7. BAR AND GRILL LICENSE:**

Have you submitted a valid food service permit or application? W.S. 12-4-413 (a)  YES  NO

**8. RESTAURANT LICENSE:**

(a) Give a description of the dispensing room(s) and state where it is located in the building. W.S. 12-4-408 (b)  
(e.g. 10 x 12 room in SE corner of building):

5x8 ROOM IN CENTRAL AREA OF BUILDING

(b) Have you submitted a valid food service permit or application? W.S. 12-4-407 (a)  YES  NO

(c) Have you attached a drawing of the establishment that includes the restaurant dispensing room(s)? W.S. 12-4-410 (f)  YES  NO

**9. RESORT LICENSE:**

Does the resort complex:

(a) Have an actual valuation of at least one million dollars, or have you committed or expended at least one million dollars (\$1,000,000.00) on the complex, excluding the value of the land? W.S. 12-4-401(b)(i)  YES  NO

(b) Include a restaurant and a convention facility which will seat at least one hundred (100) persons? W.S. 12-4-401(b)(ii)  YES  NO

(c) Include motel, hotel or privately owned condominium, town house or home accommodations approved for short term occupancy with at least one hundred (100) sleeping rooms? W.S. 12-4-401(b)(iii)  YES  NO

(d) If no on question (c), have a ski resort facility open to the general public in which you have committed or expended not less than 10 million dollars (\$10,000,000.00)? W.S. 12-4-401(b)(iv)  YES  NO

(e) Are you contracting/leasing the food and beverage services? W.S. 12-4-403(b)  
1. If Yes, have you submitted a copy of the food and beverage contract/lease?  YES  NO

**10. MICROBREWERY LICENSE:**

Will the license be held in conjunction with another liquor license? W.S. 12-4-412(b)(iii)  YES  NO

(a) If "YES", please specify type:  RETAIL  RESTAURANT  RESORT  BAR AND GRILL  WINERY

(b) Do you self distribute your products? W.S. 12-2-201(a) (Requires wholesaler license with the Liquor Division)  YES  NO

(c) Do you distribute your products through an existing malt beverage wholesaler? W.S. 12-2-201(g)(i) (Requires authorization to sell license with the Liquor Division)  YES  NO

**11. WINERY LICENSE:**

Will the license be held in conjunction with another liquor license? W.S. 12-4-412(b)(iii)  YES  NO

(a) If "YES", please specify type:  RETAIL  RESTAURANT  RESORT  BAR AND GRILL  MICROBREWERY

**12. LIMITED RETAIL (CLUB) LICENSE:**

**FRATERNAL CLUBS** W.S. 12-1-101(a)(iii)(B)

(a) Has the fraternal organization been actively operating in at least thirty-six (36) states?  YES  NO

(b) Has the fraternal organization been actively in existence for at least twenty (20) years?  YES  NO

**13. LIMITED RETAIL (CLUB) LICENSE:**

**VETERANS CLUBS** W.S. 12-1-101(a)(iii)(A):

(a) Does the Veteran's organization hold a charter by the Congress of the United States?  YES  NO

(b) Is the membership of the Veteran's organization comprised only of Veterans and its duly organized auxiliary?  YES  NO

**14. LIMITED RETAIL (CLUB) LICENSE:**

**GOLF CLUBS** W.S. 12-1-101(a)(iii)(D)/W.S. 12-4-301(e):

(a) Do you have more than fifty (50) bona fide members?  YES  NO

(b) Do you own, maintain, or operate a bona fide golf course together with clubhouse?  YES  NO

(c) Are you a political subdivision of the state that owns, maintains, or operates a golf course?  YES  NO

1. Are you contracting/leasing the food and beverage services? W.S. 12-5-201(g)  YES  NO

2. If Yes, have you submitted a copy of the food and beverage contract/lease?  YES  NO

15. LIMITED RETAIL (CLUB) LICENSE:

SOCIAL CLUBS W.S. 12-1-101(a)(iii)(E)/W.S. 12-4-301(b):

- (a) Do you have more than one hundred (100) bona fide members who are residents of the county in which the club is located?  YES  NO
- (b) Is the club incorporated and operating solely as a nonprofit organization under the laws of this state?  YES  NO
- (c) Is the club qualified as a tax exempt organization under the Internal Revenue Service?  YES  NO
- (d) Has the club been in continuous operation for a period of not less than one (1) year?  YES  NO
- (e) Has the club received twenty-five dollars (\$25.00) from each bona fide member as recorded by the secretary of the club and are club members at the time of this application in good standing by having paid at least one (1) full year in dues?  YES  NO
- (f) Does the club hold quarterly meetings and have an actively engaged membership carrying out the objectives of the club?  YES  NO
- (g) Have you filed a true copy of your bylaws with this application?  YES  NO
- (h) Has at least fifty one percent (51%) of the membership signed a petition indicating a desire to secure a Limited Retail Liquor License? (Petition Attached)  YES  NO

REQUIRED ATTACHMENTS:

- A statement indicating the financial condition and financial stability of the applicant W.S. 12-4-102 (a) (vi).
- Restaurants: include a drawing of the establishment that includes the dispensing room(s) W.S. 12-4-410 (f).
- Attach any lease agreements (especially for resort/political subdivisions leasing out food & beverage services) W.S. 12-4-103 (a) (iii)/ W.S. 12-4-403(b)/W.S. 12-4-301(e).
- If transferring a license from one ownership to another, a form of assignment from the current licensee to the new applicant authorizing the transfer W.S. 12-4-601 (b).

OATH OR VERIFICATION

(Requires signatures by ALL Individuals, ALL Partners, ONE (1) LLC Member, or TWO (2) Corporate Officers or Directors except that if all the stock of the corporation is owned by ONE (1) individual then that individual may sign and verify the application upon his oath, or TWO (2) Club Officers.) W.S. 12-4-102(b)

Under penalty of perjury, and the possible revocation or cancellation of the license, I swear the above stated facts, are true and accurate.

STATE OF WYOMING )  
COUNTY OF Natrona ) SS.

Signed and sworn to before me on this 9th day of Jan 2021  
that the facts alleged in the foregoing instrument are true by the following:

1) <u>[Signature]</u> (Signature)	<u>Allen Hanser</u> (Printed Name)	<u>COO</u> Title
2) <u>[Signature]</u> (Signature)	<u>Nicole Boltz</u> (Printed Name)	<u>CFO</u> Title
3) <u>[Signature]</u> (Signature)	<u>Justin Boltz</u> (Printed Name)	<u>CEO</u> Title
4) _____ (Signature)	_____ (Printed Name)	_____ Title
5) _____ (Signature)	_____ (Printed Name)	_____ Title
6) _____ (Signature)	_____ (Printed Name)	_____ Title

Witness my hand and official seal:

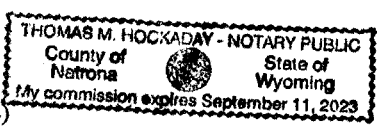

[Signature]  
Signature of Notary Public

(SEAL)

My commission expires: 9/11/2023 115

AFFIDAVIT OF WEBSITE PUBLICATION

State of Wyoming)  
County of Natrona)

I, the undersigned, being in the employ of the City of Casper and responsible for the publishing and posting of notices for the Casper City Council's public hearings concerning liquor licensing, and knowing the facts herein set forth do solemnly swear that:

- Notice of the public hearing set forth below was posted continually on the City of Casper website in accordance with W.S. 12-4-104. The said posting commenced on 01/19/2021 and ended on 02/03/2021 and
- Attached is image of the Notice as actually posted on the City of Casper website (www.caserwy.gov) for the entire period referenced above.

By: Carla Mills-Saatch

Date: 1/18/2021

Title: Licensing Specialist

Scribed in my presence and sworn before me on this

18<sup>th</sup> day of January, 2021

Christa K. Wiggs

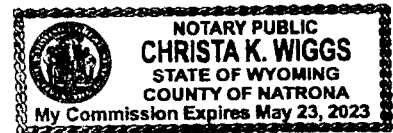

Provide to City of Casper Central Records



## NEW RESTAURANT LIQUOR LICENSE

An application for a new Restaurant Liquor License No. 43, Ludovico d/b/a Ludovico, located at 1301 Wilkins Circle has been received in this office. Public Hearing on said application will be held on February 2, 2021, at 6:00 p.m. in the City Council Chambers at 200 North David, Casper, Wyoming.

## Carla Mills-Laatsch

---

**From:** Ben - Gruner Brewing <ben@grunerbrewing.com>  
**Sent:** Monday, January 11, 2021 8:17 AM  
**To:** Carla Mills-Laatsch  
**Cc:** Allen Hanson; tonymacmillan@yahoo.com; Marketing@firehousepizzawoodfired.com; Sonya Gruner  
**Subject:** RE: Permission for Luduvico to apply and use Resturnat Liquor license

CAUTION: This email originated from outside of the organization. Do not click links or open attachments unless you recognize the sender and know the content is safe.

Carla,

Please consider this as my letter confirming that Gruner Brothers Brewing will allow Ludovico as an unrelated independent business to serve and sell alcoholic beverages to their customers in our Taproom area located at 1301 Wilkins Circle. Please let me know if you need anything additional.

Thanks,



**Ben Gruner**  
**GRUNER BROTHERS BREWING**

1301 Wilkins Circle, Casper, WY 82601

**PHONE:** 307-439-2222

**CELL:** 307-259-2323

**EMAIL:** ben@grunerbrewing.com



---

**From:** Ben - Gruner Brewing  
**Sent:** Thursday, January 07, 2021 9:41 AM  
**To:** 'Carla Mills-Laatsch'  
**Cc:** 'Allen Hanson'; 'tonymacmillan@yahoo.com'; Sonya Gruner  
**Subject:** Permission for Luduvico to apply and use Resturnat Liquor license

Carla,

Gruner Brothers Brewing agrees to let Ludovico as our tenant apply for and use upon approval of City of Casper a Restaurant Liquor License for use in the combined space (AKA GBB taproom area) that we also utilize at 1301 Wilkins Circle Casper Wyoming. If you have any questions please let me know.

Best regards,



**Ben Gruner**  
**GRUNER BROTHERS BREWING**

1301 Wilkins Circle, Casper, WY 82601

**PHONE:** 307-439-2222

**CELL:** 307-259-2323

**EMAIL:** ben@grunerbrewing.com



January 20, 2021

MEMO TO: City Council  
J. Carter Napier, City Manager 

FROM: John Henley, City Attorney 

SUBJECT: An Ordinance Amending Chapter 9.24 of the Casper Municipal Code –  
Offenses Against Public Decency, Modifying Certain Sections and Creating  
New Sections Thereof.

**Meeting Type & Date**

Regular Council Meeting  
February 2, 2021

**Action type**

Third Reading

**Recommendation**

Determine if the proposed ordinance should be passed on Third Reading.

**Summary**

The Casper Police Department and Natrona County Sheriff's Office have seen several cases of prostitution which involve human trafficking. These victims of human trafficking, frequently vulnerable females, often have come to the United States from other countries for promised employment and a path to citizenship. Others victims come from the ranks of nation's youths, who having run away and are living under desperate conditions on the street, are "recruited" with the promise safety and employment. However, instead of legal employment, these individuals are frequently trapped into a system where they are used as a commodity in the sex trade.

This Ordinance will not stop human trafficking, but it will give law enforcement an opportunity to investigate and prosecute prostitution, not only against the business owners who are involved in human trafficking but against individuals who solicit prostitution.

Council adopted, on Second Reading, Amendment No. 1 to the proposed ordinance correcting a typographical error in Section 9.24.050, Subsection A, which is incorporated into the attached Ordinance for the Third Reading.

**Financial Considerations**

None

**Oversight/Project Responsibility**

Keith McPheeters, Chief of Police  
City Attorney's Office

**Attachments**

Proposed Ordinance

ORDINANCE NO. 1-21 AMENDED

AN ORDINANCE AMENDING CHAPTER 9.24 OF THE CASPER MUNICIPAL CODE - OFFENSES AGAINST PUBLIC DECENCY, MODIFYING CERTAIN SECTIONS AND CREATING NEW SECTIONS THEREOF.

WHEREAS, the governing body of the City of Casper has the authority granted by Wyoming State Statute §15-1-103(a)(xiii) and (xli) to adopt ordinances and resolutions necessary to protect the health, safety and welfare of the City and of its citizens; and,

WHEREAS, the governing body of the City of Casper may perform all acts in relation to the concerns of the city necessary to the exercise of its corporate powers; and,

WHEREAS, those powers include the stated action of suppressing or prohibiting houses of prostitution and other disorderly houses illegal sexual services; and,

WHEREAS, the Casper Municipal Code needs updated and modified from time to time; and,

WHEREAS, the governing body of the City of Casper desires to update and amend the following Sections of Chapter 9.24 Offenses Against Public Decency.

NOW, THEREFORE, BE IT ORDAINED BY THE GOVERNING BODY OF THE CITY OF CASPER, WYOMING: that the following Sections of Chapter 9.24 Offenses Against Public Decency, are hereby updated and amended as follows:

9.24.040 - Prostitution—Defined—Prohibited.

A. For the purposes of this section:

1. "Prostitution" means any person who performs, offers or agrees to perform any act of:
  - a. ~~s~~Sexual intrusion as defined or referenced in this section subsection for any money, property, token, object, or article or anything of value, or or, any touching, manipulation or fondling of the sex organs of one person, whether by touch or the physical use of other items, by another person for any money, property, token, object or article or anything of value, for the purpose of sexual arousal or gratification of any or all of the participants. commits an act of prostitution.
  - b. Performance prostitution as defined and/or referenced in this section for any money, property, token, object, article or anything of value.
2. "Sexual intrusion" means and is defined as in Section 6-2-301 of the Wyoming Statutes, ~~to wit:~~



- a. Any intrusion, however slight, by any object or any part of a person's body, except the mouth, tongue or penis, into the genital or anal opening of another person's body if that sexual intrusion can reasonably be construed as being for the purposes of sexual arousal, gratification or abuse, or
- b. Sexual intercourse, cunnilingus, fellatio, analingus or anal intercourse with or without emission.

3. “Performance prostitution” means any touching, manipulation or fondling of the sex organs and/or areola by one person upon themselves or by one person upon the person of another, whether by touch or the physical use of other items, for the purpose of sexually arousing or sexually gratifying the person who paid for and/or financed the sexual arousal or sexual gratification.

- B. No person shall keep, set up, maintain or operate any place, structure, building or conveyance in which an act or acts of prostitution are performed or for the purpose of prostitution, ~~or~~ with knowledge or reasonable cause to know that the same is or is to be used for such purpose, or receive or offer to agree to receive any person in any place, structure, building or conveyance for the purpose of prostitution, or permit any person to remain therein for such purpose.
- C. No person shall direct, take, transport or offer or agree to take or transport, any person to any place, structure or building or to any other person with knowledge or reasonable cause to know that the purpose of such directing, taking or transporting is for an act of prostitution.
- D. No person shall reside in, enter or remain in any place, structure or building, or enter or remain in any conveyance for the purpose of prostitution.
- E. No person shall engage in or solicit prostitution, ~~or~~ aid or abet prostitution or obtain financial or pecuniary benefit from prostitution; by solicitation or by any means whatsoever.
- F. No person shall solicit an act of prostitution, whether such person is requesting an act of prostitution or offering an act of prostitution.

(Ord. 17-87 § 1, 1987: prior code § 26-33)

(Ord. No. 20-15, § 1, 9-1-2015)

9.24.050-045 - Prostitution—Evidence in prosecutions.

In the trial of any person charged with the violation of any of the provisions of Section 9.24.040, consistent with the United States Constitution, the Wyoming Constitution and the Wyoming Rules of Evidence, testimony of a prior conviction or testimony concerning the reputation of any place, structure or building and of the persons who reside in or frequent the same and of the defendant shall be admissible in evidence in support of the charge.



(Prior code § 26-34)

9.24.050 – Prostitution and Public Indecency Penalties – Administrative Consequences.

- A. No owner, lessee, lessor, operator, manager, agent or employee of a business, place, structure, or conveyance or any licensee thereof, shall permit an act of prostitution under Wyoming Statutes Section 6-4-101 or Section 9.24.040 of this Code, public indecency under Section 9.24.020 of this Code or Wyoming Statutes Section 6-4-201, or shall engage in the sexual exploitation of children under Wyoming Statutes Section 6-4-303.
- B. Any owner convicted of violating the statutes or ordinances referenced in this Section or aiding, abetting or inciting any violation thereof, shall in addition to the penalties prescribed by ordinance or statute, be subject to the administrative suspension or revocation of such individuals or entities license(s) and/or permit(s) for all business operations and activities at the location where the act(s) of prostitution were committed; aiding and abetting or inciting a violation is also sufficient cause for the revocation or suspension of the individuals or entities license(s) and/or permit(s).

9.24.055 – Severability.

If any one or more section, subsection, sentence, clause, phrase, word, provision or application of this code chapter, shall for any person or circumstance, be held to be illegal, invalid, and/or unconstitutional, such decision shall not affect the validity of any other sections, subsections, sentence, clause, phrase, word, provision or application of this code chapter which is operable without the offending section, subsection, sentence, clause, phrase, word, provision or application shall remain effective notwithstanding such illegal, invalid, unenforceable, and/or unconstitutional section, subsection, sentence, clause, phrase, word, provision or application, and every section, subsection, sentence, clause, phrase, word, provision or application of this code chapter are declared severable. The governing body hereby declares that it would have passed each part, and each provision, section, subsection, sentence, clause, phrase or word thereof, irrespective of the fact that any one or more section, subsection, sentence, clause, phrase, word, provision or application be declared illegal, invalid, and/or unconstitutional.

PASSED on 1<sup>st</sup> reading the 5<sup>th</sup> day of January, 2021

PASSED on 2<sup>nd</sup> reading the 19<sup>th</sup> day of January, 2021

PASSED, APPROVED, AND ADOPTED on third and final reading the \_\_\_\_\_ day of \_\_\_\_\_, 2021.

APPROVED AS TO FORM:

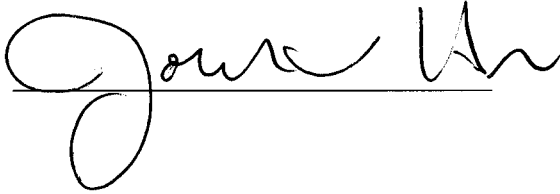

A handwritten signature in black ink, appearing to read "Fleur Tremel", written over a horizontal line.

ATTEST:

---

Fleur Tremel  
City Clerk

CITY OF CASPER, WYOMING  
A Municipal Corporation

---

Steven K. Freel  
Mayor



ORDINANCE NO. 2-21

AN ORDINANCE AMENDING SECTION 10.24.010 OF THE  
CASPER MUNICIPAL CODE PERTAINING TO TWENTY MILE  
PER HOUR SPEED ZONES

WHEREAS, Casper City Council and City Staff support revising the core downtown 20 mile per hour area.

NOW, THEREFORE, BE IT ORDAINED BY THE GOVERNING BODY OF THE CITY OF CASPER, WYOMING:

That Section 10.24.010.A of Chapter 10.24 of the Casper Municipal Code is hereby amended to read as follows:

- A. Center Street from B Street to Collins Drive; 2<sup>nd</sup> Street from David Street to Kimball Street; Midwest Avenue from Poplar Street to Durbin Street; Yellowstone Hwy from Poplar Street to David Street; Collins Drive from Center Street to Kimball Street; Kimball Street from 1<sup>st</sup> Street to Collins Drive; Beech Street from 1<sup>st</sup> Street to Collins Drive; Durbin Street from 1<sup>st</sup> Street to Collins Drive; Wolcott Street from 1<sup>st</sup> Street to Collins Drive; Ash Street from BC Street to Collins Drive; Elm Street from 1<sup>st</sup> Street to Midwest Avenue; Oak Street from Industrial Avenue to Midwest Avenue; Spruce Street from Industrial Avenue to Midwest Avenue; Walnut Street from Yellowstone Hwy to Collins Drive; Chestnut Street from Midwest Avenue to Wimborne Street; Wimborne Street; Industrial Avenue from Spruce Street to David Street; 2<sup>nd</sup> Street from Nichols Avenue to Ash Street; Nichols Avenue from B Street to 2<sup>nd</sup> Street; B Street from Nichols Avenue to A Street; A Street from Nichols Avenue to David Street; A Street from Center Street to Wolcott Street; Market Street; David Street from north of BC Street by the railroad tracts to Collins Drive.

This Ordinance shall become in full force and effect upon passage on third reading and publication.

PASSED on 1<sup>st</sup> reading the 5<sup>th</sup> day of January, 2021.

PASSED on 2<sup>nd</sup> reading the 19<sup>th</sup> day of January, 2021.

PASSED, APPROVED AND ADOPTED on 3<sup>rd</sup> and final reading the \_\_\_\_ day of

\_\_\_\_\_, 2021.

APPROVED AS TO FORM:

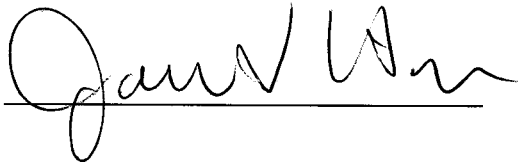

A handwritten signature in black ink, appearing to read "Fleur D. Tremel", is written over a solid horizontal line.

CITY OF CASPER, WYOMING

ATTEST:

A Municipal Corporation

---

Fleur D. Tremel  
City Clerk

---

Steven K. Freel  
Mayor

10.24.010 - Twenty mile per hour speed zones.

The following areas shall be designated as twenty mile per hour speed zones:

- A. Beginning at the point of intersection of "E" Street with Center Street, which is the northwesterly corner of the area described, thence easterly along the northern border of "E" Street extended in an easterly direction to the imaginary intersection of Park Street, thence southerly along the eastern border of Park Street to 3rd Street, thence westerly along the southern border of 3rd Street to Collins Drive; thence westerly along the southern border of Collins Drive to Durbin Street; thence southerly along the eastern border of Durbin Street to 6th Street, thence westerly along the southern border of 6th Street to Ash Street, thence northerly along the western border of Ash Street to Midwest Avenue, thence westerly to the west edge of Spruce Street, thence to the extended projection of the intersection of Spruce Street with West "C" Street and West 1st, thence northerly along the west side of West "C" Street to West "BC" Street to the extended intersection of West "BC" Street with Center Street, thence northerly along the western border of Center Street to the point of beginning;
- B. Columbine from Daffodil to Honeysuckle.
- C. South Conwell Street from East 1st Street to East 5th Street; East 5th Street from South McKinley Street to South Conwell Street; and all streets between South McKinley Street and South Conwell Street and East 2nd Street and East 5th Street.

(Ord. 12-00 § 1, 2000; Ord. 2-88 (part); Ord. 88-87, 1987; prior code § 24-30)

(Ord. No. 22-09, § 1, 11-3-2009; Ord. No. 3-19, 3-5-2019; Ord. No. 33-19, 12-17-2019)





# Highland Park Cemetery Addition No. 2





CERTIFICATE OF DEDICATION

STATE OF WYOMING } ss  
 COUNTY OF NATRONA

THE UNDERSIGNED, CITY OF CASPER, DOES HEREBY CERTIFY THAT THEY ARE THE OWNER AND PROPRIETOR OF THE FOLLOWING DESCRIBED PARCEL OF LAND BEING A VACATION AND REPLAT OF HIGHLAND PARK CEMETERY PLAT AND INCLUDING UNPLATTED PORTIONS OF THE N½SE¼ OF SECTION 10, T.33N., R.79W., AND SITUATE WITHIN THE S½E¼ AND THE N½E¼ OF SECTION 10, T.33N., R.79W., 6TH P.M., CITY OF CASPER, NATRONA COUNTY, WYOMING, BEING MORE PARTICULARLY DESCRIBED AS FOLLOWS:

COMMENCING AT THE NORTHEAST CORNER OF THE HIGHLAND PARK CEMETERY PLAT MONUMENTED BY A BRASS CAP AND BEING THE POINT OF BEGINNING;  
 THENCE S12°04'33"W, A DISTANCE OF 197.48 FEET TO AN ANGLE POINT, MONUMENTED BY A BRASS CAP;  
 THENCE S19°15'05"W, A DISTANCE OF 125.27 FEET TO AN ANGLE POINT, MONUMENTED BY A BRASS CAP;  
 THENCE S02°48'21"E, A DISTANCE OF 628.15 FEET TO AN ANGLE POINT, MONUMENTED BY A BRASS CAP;  
 THENCE N84°39'31"E, A DISTANCE OF 186.79 FEET TO AN ANGLE POINT, MONUMENTED BY A BRASS CAP;  
 THENCE S04°36'18"E, A DISTANCE OF 600.69 FEET TO AN ANGLE POINT, MONUMENTED BY A BRASS CAP;  
 THENCE S07°41'07"E, A DISTANCE OF 663.58 FEET TO AN ANGLE POINT, MONUMENTED BY A BRASS CAP;  
 THENCE S02°43'53"E, ALONG THE WEST LINE OF SOUTH LOWELL STREET, A DISTANCE OF 265.46 FEET TO THE SOUTHWEST CORNER OF THE HIGHLAND PARK CEMETERY PLAT ALSO BEING THE NORTHEAST CORNER OF LOT 2, HIGHLAND PARK ADDITION NO. 3, MONUMENTED BY A BRASS CAP;  
 THENCE S88°53'33"W, ALONG THE NORTH LINE OF LOT 2, HIGHLAND PARK ADDITION NO. 3, A DISTANCE OF 315.03 FEET TO THE NORTHWEST CORNER OF HIGHLAND PARK ADDITION NO. 3, MONUMENTED BY A BRASS CAP;

THENCE N01°04'02"W, ALONG THE EAST LINE OF HIGHLAND PARK ADDITION NO. 5, A DISTANCE OF 17.13 FEET TO THE NORTHEAST CORNER OF LOT 1, HIGHLAND PARK ADDITION NO. 5, MONUMENTED BY A BRASS CAP;

THENCE S89°17'20"W, ALONG THE NORTH LINE OF LOT 1, HIGHLAND PARK ADDITION NO. 5, A DISTANCE OF 269.84 FEET TO THE NORTHWEST CORNER OF SAID LOT 1, HIGHLAND PARK ADDITION NO. 5, MONUMENTED BY A BRASS CAP;

THENCE N01°59'15"W, ALONG THE EAST LINE OF LOT 2, HIGHLAND PARK ADDITION NO. 5, A DISTANCE OF 148.57 FEET TO THE NORTHEAST CORNER OF SAID LOT 2, HIGHLAND PARK ADDITION NO. 5, MONUMENTED BY A BRASS CAP;

THENCE S87°42'37"W, ALONG THE NORTH LINE OF SAID LOT 2, HIGHLAND PARK ADDITION NO. 5, A DISTANCE OF 33.47 FEET TO AN ANGLE POINT, MONUMENTED BY A BRASS CAP;

THENCE N44°07'56"E, A DISTANCE OF 148.27 FEET TO AN ANGLE POINT, MONUMENTED BY A BRASS CAP;  
 THENCE N08°26'58"E, A DISTANCE OF 285.49 FEET TO AN ANGLE POINT, MONUMENTED BY A BRASS CAP;

THENCE N62°37'52"W, A DISTANCE OF 156.23 FEET TO AN ANGLE POINT, MONUMENTED BY A BRASS CAP;  
 THENCE N88°49'29"W, A DISTANCE OF 229.38 FEET TO AN ANGLE POINT, MONUMENTED BY A BRASS CAP;

THENCE S42°34'48"W, A DISTANCE OF 269.25 FEET TO AN ANGLE POINT, MONUMENTED BY A BRASS CAP;  
 THENCE S20°20'22"W, A DISTANCE OF 425.76 FEET TO AN ANGLE POINT, MONUMENTED BY A BRASS CAP;

THENCE S07°58'05"W, A DISTANCE OF 236.06 FEET TO A POINT LOCATED ON THE NORTH LINE OF EAST TWELFTH STREET, MONUMENTED BY A BRASS CAP;

THENCE S89°40'44"W, ALONG THE NORTH LINE OF EAST TWELFTH STREET, A DISTANCE OF 348.71 FEET TO THE SOUTHWEST CORNER OF THE PARCEL, MONUMENTED BY A BRASS CAP;

THENCE N00°52'03"W, ALONG THE WEST LINE OF THE PARCEL AND THE EAST LINE OF SOUTH CONNELL STREET, A DISTANCE OF 853.69 FEET TO THE SOUTHWEST CORNER OF HIGHLAND PARK CEMETERY PLAT, MONUMENTED BY A BRASS CAP;

THENCE N00°16'04"W, ALONG THE WEST LINE OF THE PARCEL AND THE EAST LINE OF SOUTH CONNELL STREET, A DISTANCE OF 1528.82 FEET TO AN ANGLE POINT, MONUMENTED BY A BRASS CAP;

THENCE N02°48'40"W, ALONG THE WEST LINE OF THE PARCEL AND THE EAST LINE OF SOUTH CONNELL STREET, A DISTANCE OF 43.19 FEET TO AN ANGLE POINT, MONUMENTED BY A BRASS CAP;

THENCE N07°33'07"W, ALONG THE WEST LINE OF THE PARCEL AND THE EAST LINE OF SOUTH CONNELL STREET, A DISTANCE OF 78.99 FEET TO AN ANGLE POINT, MONUMENTED BY A BRASS CAP;

THENCE N02°23'37"W, ALONG THE WEST LINE OF THE PARCEL AND THE EAST LINE OF SOUTH CONNELL STREET, A DISTANCE OF 127.68 FEET TO AN ANGLE POINT, MONUMENTED BY A BRASS CAP WITNESS CORNER;

THENCE N69°56'23"E, ALONG THE WEST LINE OF THE PARCEL AND THE EAST LINE OF SOUTH CONNELL STREET, A DISTANCE OF 18.93 FEET TO THE NORTHWEST CORNER OF HIGHLAND PARK CEMETERY PLAT, MONUMENTED BY A BRASS CAP;

THENCE N89°18'01"E, ALONG THE NORTH LINE OF THE PARCEL AND THE SOUTH LINE OF EAST 4TH STREET, A DISTANCE OF 1299.77 FEET TO THE POINT OF BEGINNING.

THE ABOVE DESCRIBED PARCEL CONTAINS 73.09 ACRES, MORE OR LESS, AND IS SUBJECT TO ANY RIGHTS-OF-WAY AND/OR EASEMENTS, RESERVATIONS, AND ENCUMBRANCES WHICH HAVE BEEN LEGALLY ACQUIRED.

THE TRACT OF LAND, AS IT APPEARS ON THIS PLAT, IS DEDICATED WITH THE FREE CONSENT AND IN ACCORDANCE WITH THE DESIRES OF THE UNDERSIGNED OWNERS AND PROPRIETORS. THE NAME OF THE SUBDIVISION SHALL BE "HIGHLAND PARK CEMETERY ADDITION NO. 2". ALL ROADS AND STREETS, AS SHOWN HEREON HAVE PREVIOUSLY BEEN DEDICATED TO THE USE OF THE PUBLIC.

TRACEY L. BELSER - CITY CLERK STEVEN FREEL - MAYOR  
 THE FOREGOING INSTRUMENT WAS ACKNOWLEDGED BEFORE ME BY TRACEY L. BELSER, CITY CLERK AND BY STEVEN FREEL, MAYOR OF THE CITY OF CASPER, THIS \_\_\_\_ DAY OF \_\_\_\_\_, 2020.

WITNESS MY HAND AND OFFICIAL SEAL  
 MY COMMISSION EXPIRES \_\_\_\_\_ NOTARY PUBLIC

VACATION & REPLAT OF  
 HIGHLAND PARK CEMETERY PLAT &  
 INCLUDING UNPLATTED PORTIONS OF THE  
 N½E¼ OF SECTION 10, T.33N., R.79W., 6TH P.M.  
 AS

HIGHLAND PARK CEMETERY ADDITION NO. 2 SHEET

AN ADDITION TO THE CITY OF CASPER, WYOMING  
 BEING A PORTION OF THE S½E¼ AND THE N½E¼ OF  
 SECTION 10, T.33N., R.79W., 6TH P.M.  
 NATRONA COUNTY, WYOMING

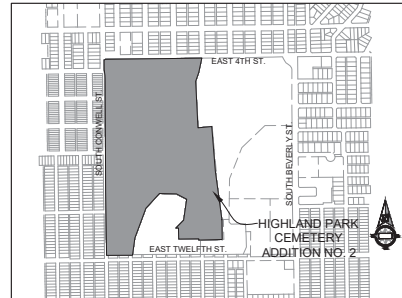

VICINITY MAP  
 NO SCALE

APPROVALS

APPROVED BY THE CITY OF CASPER PLANNING AND ZONING COMMISSION OF CASPER, WYOMING  
 THIS \_\_\_\_ DAY OF \_\_\_\_\_, 2020.

ATTEST: \_\_\_\_\_ SECRETARY \_\_\_\_\_ CHAIRMAN

APPROVED BY THE CITY COUNCIL OF CASPER, WYOMING BY RESOLUTION NO. \_\_\_\_\_ DAILY PASSED,  
 ADOPTED AND APPROVED THIS \_\_\_\_ DAY OF \_\_\_\_\_, 2020.

ATTEST: \_\_\_\_\_ CITY CLERK \_\_\_\_\_ MAYOR

INSPECTED AND APPROVED THIS \_\_\_\_ DAY OF \_\_\_\_\_, 2020. \_\_\_\_\_ CITY ENGINEER

INSPECTED AND APPROVED THIS \_\_\_\_ DAY OF \_\_\_\_\_, 2020. \_\_\_\_\_ CITY SURVEYOR

NOTES

1. ERROR OF CLOSURE EXCEEDS 1:217,099.
2. BASIS OF BEARING IS THE WYOMING STATE PLANE COORDINATE SYSTEM, EAST CENTRAL ZONE, NAD 1983/86.
3. THE CONVERGENCE ANGLE AT THE POINT OF BEGINNING IS 0°04'03.907", AND THE COMBINED FACTOR IS 0.999779.
4. DISTANCES: U.S. SURVEY FOOT
5. ELEVATIONS SHOWN HEREON ARE BASED ON NAVD 88 DATUM AND ARE NOT MEANT TO BE USED AS BENCHMARKS.

CERTIFICATE OF SURVEYOR

STATE OF WYOMING } ss  
 COUNTY OF NATRONA

I, WILLIAM R. FEHRINGER, A REGISTERED PROFESSIONAL LAND SURVEYOR, LICENSE NO. 5528, DO HEREBY CERTIFY THAT THIS PLAT WAS MADE FROM NOTES TAKEN DURING AN ACTUAL SURVEY MADE UNDER MY DIRECT SUPERVISION IN JANUARY, 2018, AND THAT THIS PLAT, TO THE BEST OF MY KNOWLEDGE AND BELIEF, CORRECTLY AND ACCURATELY REPRESENTS SAID SURVEY. ALL DIMENSIONS ARE EXPRESSED IN FEET AND DECIMALS THEREOF. COURSES ARE REFERRED TO THE WYOMING STATE PLANE COORDINATE SYSTEM, EAST CENTRAL ZONE, NAD 1983/86, CITY OF CASPER GIS SYSTEM ALL BEING TRUE AND CORRECT TO THE BEST OF MY KNOWLEDGE AND BELIEF.

THE FOREGOING INSTRUMENT WAS ACKNOWLEDGED BEFORE ME BY WILLIAM R. FEHRINGER  
 THIS DAY OF \_\_\_\_\_, 2020.

WITNESS MY HAND AND OFFICIAL SEAL  
 MY COMMISSION EXPIRES \_\_\_\_\_ NOTARY PUBLIC

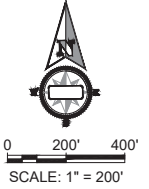
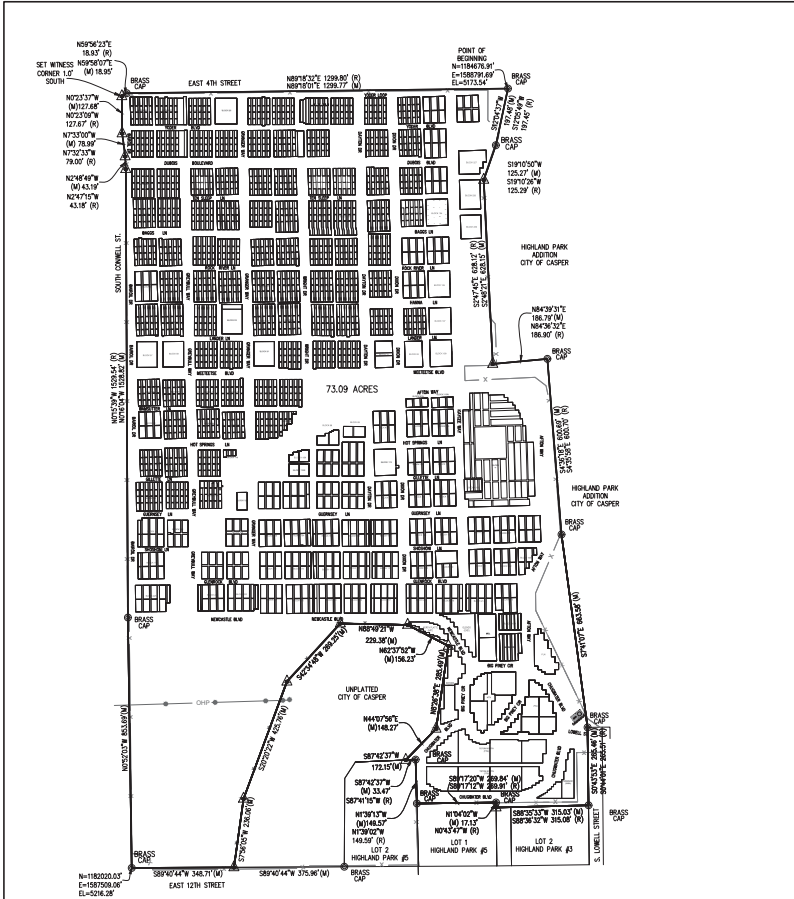

LEGEND

- SET BRASS CAP
- ▲ SET MONUMENT 5/8" REBAR & ALUMINUM CAP
- FOUND MONUMENT AS NOTED



Civil Engineering Professionals, Inc.  
 6080 Enterprise Drive, Casper, WY 82609  
 Phone 307.266.4346 Fax 307.266.0103  
 www.cepi-casper.com

M:\Land 2017\Survey\17-250 Highland Cemetery Survey Plat\WPC REVISION.dwg, 3/20/2020, Survey

M:\Land 2017\Survey\17-250 Highland Cemetery\Survey\Plat\HPC REVIS02.dwg, 1/17/2018, Survey

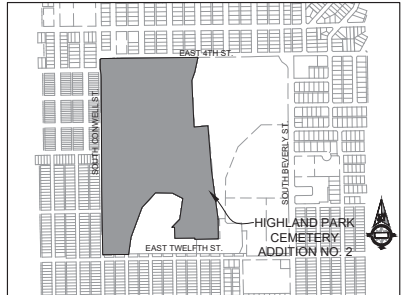
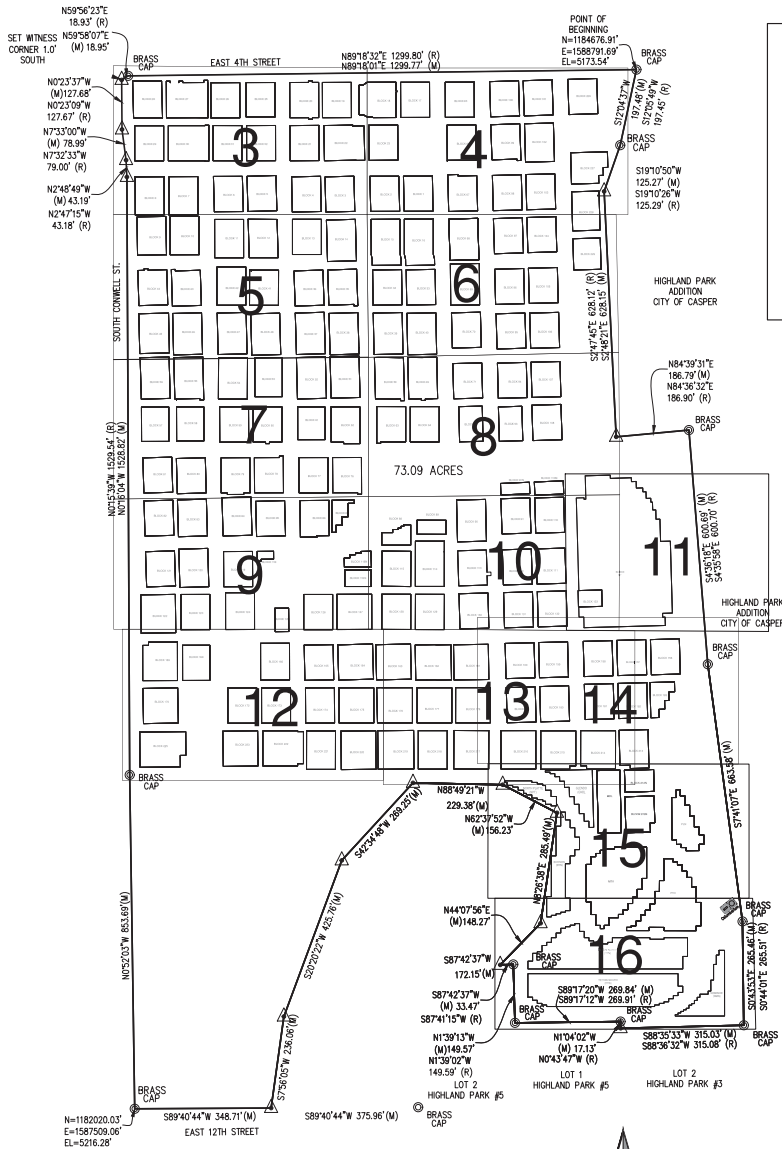

VICINITY MAP  
NO SCALE



Civil Engineering Professionals, Inc.  
6080 Enterprise Drive Casper, WY 82609  
Phone 307.266.4346 Fax 307.266.0103  
www.cepi-casper.com

- LEGEND**
- ▲ SET BRASS CAP
  - SET MONUMENT 5/8" REBAR & ALUMINUM CAP
  - FOUND MONUMENT AS NOTED



SCALE: 1" = 150'

VACATION & REPLAT OF  
HIGHLAND PARK CEMETERY PLAT &  
INCLUDING UNPLATTED PORTIONS OF THE  
N½E¼ OF SECTION 10, T.33N., R.79W., 6TH P.M.  
AS  
**HIGHLAND PARK CEMETERY ADDITION NO. 2** SHEET

AN ADDITION TO THE CITY OF CASPER, WYOMING  
BEING A PORTION OF THE S½NE¼ AND THE N½E¼ OF  
SECTION 10 T.33N., R.79W., 6TH P.M.  
NATRONA COUNTY, WYOMING

EAST 4TH STREET

N89°18'01"E 1299.77' (M)

N59°58'07"E 18.95' (M)

N0°23'57"W 127.68' (M)

SOUTH CONWELL ST.

N73°10'0"W 78.89' (M)

N72°48'49"W 43.18' (M)

N0°10'40"E 286.82' (M)



LEGEND

- SET BRASS CAP
- SET MONUMENT 5/8" REBAR & ALUMINUM CAP
- FOUND MONUMENT AS NOTED



Civil Engineering Professionals, Inc.  
 6080 Enterprise Drive, Casper, WY 82609  
 Phone 307.266.4346 Fax 307.266.0103  
 www.cepi-casper.com

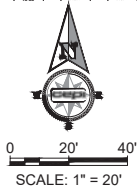

VACATION & REPLAT OF  
 HIGHLAND PARK CEMETERY PLAT &  
 INCLUDING UNPLATTED PORTIONS OF THE  
 N½E¼ OF SECTION 10, T.33N., R.79W., 6TH P.M.  
 AS  
**HIGHLAND PARK CEMETERY ADDITION NO. 2**

AN ADDITION TO THE CITY OF CASPER, WYOMING  
 BEING A PORTION OF THE S½E¼ AND THE N½E¼ OF  
 SECTION 10, T.33N., R.79W., 6TH P.M.  
 NATRONA COUNTY, WYOMING

SHEET

3 of 17

W.O. #17-250

M. Vard, 2013 Survey #17-250, Highland Cemetery Survey, Plat #VAC REVISOR, Aug. 1/17/2018, Survey



EAST 4TH STREET

S8918.01'W 1299.77' (M)

YODER LOOP



LEGEND

- ▲ SET BRASS CAP
- SET MONUMENT 5/8" REBAR & ALUMINUM CAP
- FOUND MONUMENT AS NOTED



Civil Engineering Professionals, Inc.  
 6080 Enterprise Drive, Casper, WY 82609  
 Phone 307.266.4346 Fax 307.266.0103  
 www.cepi-casper.com



0 20' 40'  
 SCALE: 1" = 20'

VACATION & REPLAT OF  
 HIGHLAND PARK CEMETERY PLAT &  
 INCLUDING UNPLATTED PORTIONS OF THE  
 N[SE]1/4 SECTION 10, T.33N., R.79W., 6TH P.M.  
 AS

HIGHLAND PARK CEMETERY ADDITION NO. 2

SHEET

AN ADDITION TO THE CITY OF CASPER, WYOMING  
 BEING A PORTION OF THE S[NE]1/4 AND THE N[SE]1/4 OF  
 SECTION 10 T.33N., R.79W., 6TH P.M.  
 NATRONA COUNTY, WYOMING

4 OF 17

M.O. #17-250

W:\Land\_2017\Survey\17-250 Highland Cemetery Survey Plot\HPC REUSED.dwg, 1/17/2018, Survey

**CEPI**  
 Civil Engineering Professionals, Inc.  
 6080 Enterprise Drive Casper, WY 82609  
 Phone 307.256.4360 Fax 307.256.0193  
 www.cepi-casper.com

- LEGEND**
- ▲ SET BRASS CAP
  - SET MONUMENT 5/8" REBAR & ALUMINUM CAP
  - FOUND MONUMENT AS NOTED

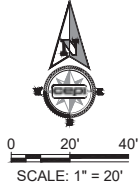

VACATION & REPLAT OF  
 HIGHLAND PARK CEMETERY PLAT &  
 INCLUDING UNPLATTED PORTIONS OF THE  
 N[1/2] OF SECTION 10, T.33N., R.79W., 6TH P.M.  
 AS  
**HIGHLAND PARK CEMETERY ADDITION NO. 2**

AN ADDITION TO THE CITY OF CASPER, WYOMING  
 BEING A PORTION OF THE S[1/2] AND THE N[1/2] OF  
 SECTION 10 T.33N., R.79W., 6TH P.M.  
 NATRONA COUNTY, WYOMING



W:\Land\_2017\Survey\17-250 Highland Cemetery Survey Plot\HPC REUSED\Ases\_1/17/2018\_Survey

- LEGEND**
- ▲ SET BRASS CAP
  - SET MONUMENT 5/8" REBAR & ALUMINUM CAP
  - FOUND MONUMENT AS NOTED

**CEPI**  
 Civil Engineering Professionals, Inc.  
 6080 Enterprise Drive Casper, WY 82609  
 Phone 307.266.4346 Fax 307.266.0103  
 www.cepi-corp.com

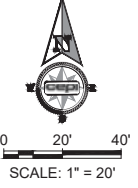

VACATION & REPLAT OF  
 HIGHLAND PARK CEMETERY PLAT &  
 INCLUDING UNPLATTED PORTIONS OF THE  
 N½E¼ OF SECTION 10, T.33N., R.79W., 6TH P.M.  
 AS  
**HIGHLAND PARK CEMETERY ADDITION NO. 2** SHEET  
 AN ADDITION TO THE CITY OF CASPER, WYOMING  
 BEING A PORTION OF THE SAME AND THE N½E¼ OF  
 SECTION 10, T.33N., R.79W., 6TH P.M.  
 NATRONA COUNTY, WYOMING  
 6 OF 17  
 M.O. #17-250

S24521'E 63.815' (M)

W:\Land\_2017\Survey\17-250 Highland Cemetery Survey Plot\HPC REUSED\Asn\_1/17/2018\_Survey

DR  
BAROIL DR  
(N) 289251 W.432.01W



- LEGEND
- ▲ SET BRASS CAP
  - SET MONUMENT 5/8" REBAR & ALUMINUM CAP
  - FOUND MONUMENT AS NOTED

**CEPI**  
Civil Engineering Professionals, Inc  
6080 Enterprise Drive Casper, WY 82609  
Phone 307.266.4346 Fax 307.266.0103  
www.cepi-casper.com

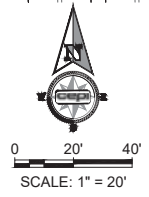

VACATION & REPLAT OF  
HIGHLAND PARK CEMETERY PLAT &  
INCLUDING UNPLATTED PORTIONS OF THE  
N½SE¼ OF SECTION 10, T.33N., R.79W., 6TH P.M.  
AS

**HIGHLAND PARK CEMETERY ADDITION NO. 2**

AN ADDITION TO THE CITY OF CASPER, WYOMING  
BEING A PORTION OF THE SAME AND THE N½SE¼ OF  
SECTION 10 T.33N., R.79W., 6TH P.M.  
NATRONA COUNTY, WYOMING



W:\Land\_2017\Survey\17-250 Highland Cemetery\Survey\Plot\HPC REVISED.dwg, 1/17/2018, Sunny



**LEGEND**

- ▲ SET BRASS CAP
- SET MONUMENT 5/8" REBAR & ALUMINUM CAP
- FOUND MONUMENT AS NOTED

**CEPI**  
 Civil Engineering Professionals, Inc.  
 6080 Enterprise Drive, Casper, WY 82009  
 Phone 307.266.4346 Fax 307.266.0103  
 www.cepi-casper.com

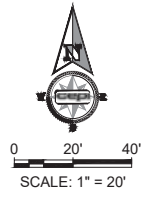

VACATION & REPLAT OF  
 HIGHLAND PARK CEMETERY PLAT &  
 INCLUDING UNPLATTED PORTIONS OF THE  
 N½E¼ OF SECTION 10, T.33N., R.79W., 6TH P.M.  
 AS

**HIGHLAND PARK CEMETERY ADDITION NO. 2** SHEET

AN ADDITION TO THE CITY OF CASPER, WYOMING  
 BEING A PORTION OF THE S½E¼ AND THE N½E¼ OF  
 SECTION 10, T.33N., R.79W., 6TH P.M.  
 NATRONA COUNTY, WYOMING

8 OF 17  
 W.O. #17-250

W:\Land\_2017\Survey\17-250 Highland Cemetery\Survey\Plot\HPC REVISED.dwg, 1/17/2018, Sunny

BARROLL DR

SOUTH CONWELL ST.  
N07°16'04"W 1528.82' (M)



LEGEND

- ▲ SET BRASS CAP
- SET MONUMENT 5/8" REBAR & ALUMINUM CAP
- FOUND MONUMENT AS NOTED

**CEPI**  
Civil Engineering Professionals, Inc.  
6080 Enterprise Drive, Casper, WY 82609  
Phone 307.266.4346 Fax 307.266.0103  
www.cepi-casper.com



VACATION & REPLAT OF  
HIGHLAND PARK CEMETERY PLAT &  
INCLUDING UNPLATTED PORTIONS OF THE  
N½E¼ OF SECTION 10, T.33N., R.79W., 6TH P.M.  
AS

**HIGHLAND PARK CEMETERY ADDITION NO. 2** SHEET

AN ADDITION TO THE CITY OF CASPER, WYOMING  
BEING A PORTION OF THE S½E¼ AND THE N½E¼ OF  
SECTION 10, T.33N., R.79W., 6TH P.M.  
NATRONA COUNTY, WYOMING



W:\Land\_2017\Survey\17-250 Highland Cemetery\Survey Plot\HPC REVISED.dwg, 1/17/2018, Survey

**LEGEND**

- ▲ SET BRASS CAP
- SET MONUMENT 5/8" REBAR & ALUMINUM CAP
- FOUND MONUMENT AS NOTED



Civil Engineering Professionals, Inc.  
 6080 Enterprise Drive, Casper, WY 82609  
 Phone 307.266.4346 Fax 307.266.0103  
 www.cepi-casper.com



SCALE: 1" = 20'  
 0 20' 40'

VACATION & REPLAT OF  
 HIGHLAND PARK CEMETERY PLAT &  
 INCLUDING UNPLATTED PORTIONS OF THE  
 N½E¼ OF SECTION 10, T.33N., R.79W., 6TH P.M.  
 AS  
**HIGHLAND PARK CEMETERY ADDITION NO. 2**

AN ADDITION TO THE CITY OF CASPER, WYOMING  
 BEING A PORTION OF THE S½E¼ AND THE N½E¼ OF  
 SECTION 10, T.33N., R.79W., 6TH P.M.  
 NATRONA COUNTY, WYOMING



W:\Land\_2017\Survey\17-250 Highland Cemetery\Survey Plot\SPC REVISED.dwg, 1/17/2018, Sunny

- LEGEND**
- ▲ SET BRASS CAP
  - SET MONUMENT 5/8" REBAR & ALUMINUM CAP
  - FOUND MONUMENT AS NOTED

**CEPI**  
 Civil Engineering Professionals, Inc.  
 6080 Enterprise Drive, Casper, WY 82609  
 Phone 307.266.4346 Fax 307.266.0103  
 www.cepi-casper.com

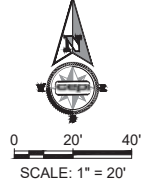

S43°36'18"E 660.60' (M)

VACATION & REPLAT OF  
 HIGHLAND PARK CEMETERY PLAT &  
 INCLUDING UNPLATTED PORTIONS OF THE  
 N½SE¼ OF SECTION 10, T.33N., R.79W., 6TH P.M.  
 AS  
**HIGHLAND PARK CEMETERY ADDITION NO. 2**

AN ADDITION TO THE CITY OF CASPER, WYOMING  
 BEING A PORTION OF THE S½NE¼ AND THE N½SE¼ OF  
 SECTION 10, T.33N., R.79W., 6TH P.M.  
 NATRONA COUNTY, WYOMING





SOUTH CONWELL ST.

NOTE: 104' W 1526.82' (M)

BAIRROLL DR

GUERNSEY LN

SHOSHONI LN

GREYBULL WAY

GRANGER WAY

GLENROCK BLVD

NEWCASTLE BLVD

NEW

- LEGEND
- ▲ SET BRASS CAP
  - SET MONUMENT 5/8" REBAR & ALUMINUM CAP
  - FOUND MONUMENT AS NOTED



Civil Engineering Professionals, Inc.  
6080 Enterprise Drive Casper, WY 82609  
Phone 307.266.4346 Fax 307.266.0103  
www.cepi-casper.com

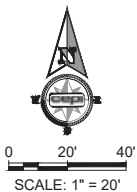

VACATION & REPLAT OF  
HIGHLAND PARK CEMETERY PLAT &  
INCLUDING UNPLATTED PORTIONS OF THE  
N½E¼ OF SECTION 10, T.33N., R.79W., 6TH P.M.  
AS  
**HIGHLAND PARK CEMETERY ADDITION NO. 2**

AN ADDITION TO THE CITY OF CASPER, WYOMING  
BEING A PORTION OF THE S½E¼ AND THE N½E¼ OF  
SECTION 10 T.33N., R.79W., 6TH P.M.  
NATRONA COUNTY, WYOMING

M:\Land\_2013\Survey\17-250 Highland Cemetery Survey Plot\HPC REUSED.dwg, 1/17/2018, Survey



W:\Land\_2017\Survey\17-250 Highland Cemetery Survey Plot\HPC REUSED.dwg, 1/17/2018, Sunny

NEWCASTLE BLVD

N88°49'21"W 229.38' (M)

- LEGEND**
- ▲ SET BRASS CAP
  - SET MONUMENT 5/8" REBAR & ALUMINUM CAP
  - FOUND MONUMENT AS NOTED

**CEPI**  
 Civil Engineering Professionals, Inc.  
 6080 Enterprise Drive, Casper, WY 82609  
 Phone 307.266.4346 Fax 307.266.0103  
 www.cepi-casper.com

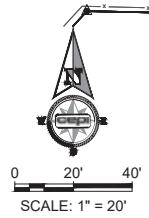

VACATION & REPLAT OF  
 HIGHLAND PARK CEMETERY PLAT &  
 INCLUDING UNPLATTED PORTIONS OF THE  
 N&E¼ OF SECTION 10, T.33N., R.79W., 6TH P.M.  
 AS

**HIGHLAND PARK CEMETERY ADDITION NO. 2** SHEET

AN ADDITION TO THE CITY OF CASPER, WYOMING  
 BEING A PORTION OF THE SAME AND THE S&NE¼ OF  
 SECTION 10, T.33N., R.79W., 6TH P.M.  
 NATRONA COUNTY, WYOMING

13 OF 17  
 M.O. #17-250



W:\Land\_2017\Survey\17-250 Highland Cemetery Survey Plot\HPC REUSED.dwg, 1/17/2018, Survey

- LEGEND**
- ▲ SET BRASS CAP
  - SET MONUMENT 5/8" REBAR & ALUMINUM CAP
  - FOUND MONUMENT AS NOTED



Civil Engineering Professionals, Inc.  
 6080 Enterprise Drive, Casper, WY 82609  
 Phone 307.266.4346 Fax 307.266.0103  
 www.cepi-casper.com

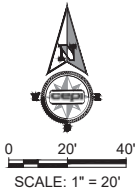

VACATION & REPLAT OF  
 HIGHLAND PARK CEMETERY PLAT &  
 INCLUDING UNPLATTED PORTIONS OF THE  
 N5E1/4 OF SECTION 10, T.33N., R.79W., 6TH P.M.  
 AS  
**HIGHLAND PARK CEMETERY ADDITION NO. 2**

AN ADDITION TO THE CITY OF CASPER, WYOMING  
 BEING A PORTION OF THE S5E1/4 AND THE N5E1/4 OF  
 SECTION 10, T.33N., R.79W., 6TH P.M.  
 NATRONA COUNTY, WYOMING

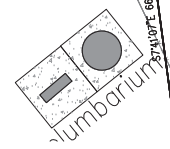

LEGEND

- ▲ SET BRASS CAP
- SET MONUMENT 5/8" REBAR & ALUMINUM CAP
- FOUND MONUMENT AS NOTED



Civil Engineering Professionals, Inc.  
 6080 Enterprise Drive, Casper, WY 82609  
 Phone 307.266.4346 Fax 307.266.0103  
 www.cepi-casper.com

0 20' 40'  
 SCALE: 1" = 20'

VACATION & REPLAT OF  
 HIGHLAND PARK CEMETERY PLAT &  
 INCLUDING UNPLATTED PORTIONS OF THE  
 N½E¼ OF SECTION 10, T.33N., R.79W., 6TH P.M.  
 AS  
**HIGHLAND PARK CEMETERY ADDITION NO. 2**

AN ADDITION TO THE CITY OF CASPER, WYOMING  
 BEING A PORTION OF THE S½E¼ AND THE N½E¼ OF  
 SECTION 10, T.33N., R.79W., 6TH P.M.  
 NATRONA COUNTY, WYOMING

W:\Land\_2013\Survey\17-250 Highland Cemetery Survey Plot\HPC REUSED.dwg, 1/17/2018, Survey



\\s:\land\_2013\Survey\17-250 Highland Cemetery Survey Plot\HPC REUSED.dwg, 1/17/2018, Survey

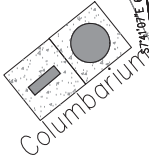
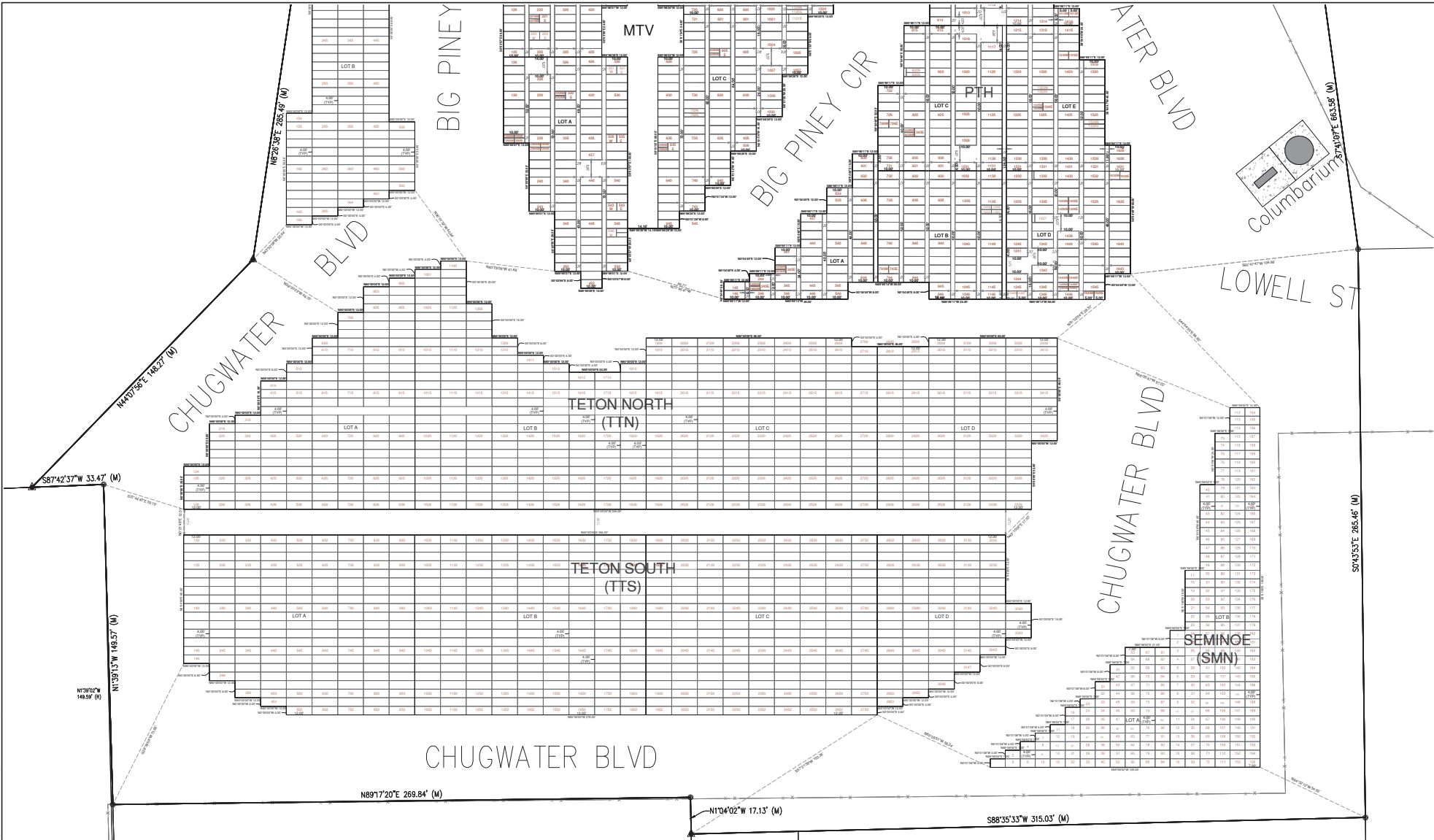

- LEGEND
- ▲ SET BRASS CAP
  - SET MONUMENT 5/8" REBAR & ALUMINUM CAP
  - FOUND MONUMENT AS NOTED

**CEPI**  
 Civil Engineering Professionals, Inc.  
 6080 Enterprise Drive Casper, WY 82609  
 Phone 307.266.4346 Fax 307.266.0103  
 www.cepi-casper.com

0 20' 40'  
 SCALE: 1" = 20'

VACATION & REPLAT OF  
 HIGHLAND PARK CEMETERY PLAT &  
 INCLUDING UNPLATTED PORTIONS OF THE  
 N½E¼ OF SECTION 10, T.33N., R.79W., 6TH P.M.  
 AS  
**HIGHLAND PARK CEMETERY ADDITION NO. 2**

AN ADDITION TO THE CITY OF CASPER, WYOMING  
 BEING A PORTION OF THE S½E¼ AND THE N½E¼ OF  
 SECTION 10, T.33N., R.79W., 6TH P.M.  
 NATRONA COUNTY, WYOMING

Parcel Line Table		
Line #	Length	Direction
L1	10.00	S89°39'28"W
L2	3.96	N0°20'33"W
L3	3.98	S0°20'32"E
L4	10.00	S89°39'28"W
L5	4.00	N0°20'33"W
L6	5.66	S0°20'32"E
L7	10.00	S89°39'28"W
L8	10.00	N89°39'35"E
L9	4.00	S0°12'32"E
L10	10.00	S89°47'28"W
L11	4.00	N0°12'32"W
L12	16.00	S89°47'31"W
L13	16.00	N89°47'28"E
L14	4.00	N0°12'15"W
L15	10.00	N89°47'28"E
L16	4.00	S0°12'15"E
L17	10.00	N89°52'50"E
L18	11.97	N54°40'26"E
L19	2.00	N89°52'56"E
L20	4.00	S0°07'10"E
L21	2.00	S89°52'49"W
L22	6.32	N71°41'12"W
L23	10.00	S89°52'49"W
L24	11.03	N62°35'15"W
L25	10.00	S89°52'49"W
L26	10.00	S87°59'06"W
L27	4.00	N2°00'55"W
L28	1.21	S0°00'54"W
L29	10.00	N89°59'06"W
L30	10.00	S89°59'06"E

Parcel Line Table		
Line #	Length	Direction
L32	4.06	S1°33'48"E
L34	12.21	S15°17'45"E
L35	16.00	S0°50'52"E
L37	16.00	N0°50'52"W
L38	13.26	N14°05'06"W
L39	12.04	N11°15'35"W
L40	16.00	N0°20'20"W
L41	16.00	S0°20'16"E
L42	11.96	S11°19'56"E
L43	16.00	N88°24'00"E
L44	4.00	N1°36'01"W
L45	10.00	N88°24'00"E
L46	4.00	S1°36'01"E
L47	10.00	N88°16'25"E
L48	4.00	S1°43'34"E
L49	10.01	S88°06'51"W
L50	4.00	N1°53'09"W
L51	10.00	S88°38'10"W
L52	4.00	N1°21'50"W
L53	10.00	N88°30'00"E
L54	6.14	S87°52'43"E
L55	10.00	N88°29'54"E
L56	6.06	S84°43'34"E
L57	10.00	N88°33'03"E
L58	5.97	S87°43'50"E
L59	10.00	N88°26'11"E
L60	6.07	S85°22'49"E
L61	10.00	N88°35'24"E
L62	10.00	S88°35'24"W
L63	4.65	N1°24'37"W

Parcel Line Table		
Line #	Length	Direction
L64	15.75	S88°26'11"W
L65	6.18	N87°51'36"W
L66	10.00	S88°33'03"W
L67	5.96	N84°36'59"W
L68	10.00	S88°29'54"W
L69	6.14	N87°52'16"W
L70	10.00	S88°29'53"W
L71	10.00	S88°39'23"W
L72	6.63	N88°25'14"W
L73	10.00	S88°27'56"W
L74	6.94	N89°20'22"W
L75	10.00	S89°22'00"W
L76	5.13	N88°58'05"W
L77	10.00	S88°29'28"W
L78	5.58	S86°13'25"W
L79	10.00	S88°51'42"W
L80	10.00	N88°51'49"E
L81	4.89	N85°52'48"E
L82	16.75	N88°29'27"E
L83	3.76	N0°38'00"W
L84	10.00	N89°22'00"E
L85	4.25	S0°38'29"E
L86	5.28	N88°27'56"E
L87	10.00	N88°27'56"E
L88	6.98	S88°34'18"E
L89	10.00	N88°39'16"E
L90	4.00	S0°01'47"W
L91	10.00	N89°58'14"W
L92	4.00	N0°04'27"W
L93	4.00	S0°09'08"W

Parcel Line Table		
Line #	Length	Direction
L94	10.00	N89°50'51"W
L95	4.00	N0°09'09"E
L96	16.00	N89°47'53"E
L97	4.00	N0°12'07"W
L98	4.00	S0°11'49"E
L99	16.00	N89°48'11"E
L100	4.00	N0°11'49"W
L101	10.00	N89°48'11"E
L102	4.00	S0°11'49"E
L103	10.00	S89°52'59"W
L104	4.00	N0°07'00"W
L105	8.00	N0°20'25"W
L106	16.00	N89°39'35"E
L107	16.00	N89°39'38"E
L108	16.00	N89°39'34"E
L109	10.00	N89°39'27"E
L110	4.00	S0°20'26"E
L111	8.00	S0°00'10"W
L112	14.00	N89°59'43"W
L113	4.00	S0°00'10"W
L114	14.40	N89°13'25"E
L115	8.00	N0°46'31"W
L116	14.40	N89°13'25"E
L117	4.00	N0°46'39"W
L118	14.40	N89°13'25"E
L119	4.00	N0°46'39"W
L120	25.80	N89°13'26"E
L121	10.00	S89°39'19"W
L122	5.00	S0°20'47"E
L123	10.00	S1°54'41"E

Parcel Line Table		
Line #	Length	Direction
L124	8.00	N88°05'15"E
L125	17.19	S1°54'40"E
L126	11.59	N88°05'12"E
L127	10.00	S1°54'47"E
L128	4.00	N88°05'06"E
L129	20.05	S1°54'40"E
L130	7.92	N88°31'03"E
L131	20.00	S1°28'56"E
L132	3.98	S1°28'59"E
L133	9.96	N88°17'49"E
L134	4.90	S1°30'15"E
L135	9.90	S1°40'08"E
L136	6.20	N88°25'05"E
L137	21.33	N89°08'46"E
L138	6.89	S89°48'54"E
L139	21.33	N89°08'28"E
L140	5.64	S84°51'26"E
L141	5.00	S89°08'29"W
L142	9.96	S88°44'26"W
L143	21.33	S89°08'28"W
L144	5.64	N84°51'27"W
L145	21.33	S89°08'28"W
L146	6.90	N89°48'58"W
L147	21.33	S89°08'46"W
L148	15.00	N89°52'10"E
L149	8.40	N0°07'50"W
L150	10.00	N88°37'55"E
L151	7.51	S88°18'43"E
L152	15.00	S88°39'31"W
L153	21.92	S1°20'27"E

Parcel Line Table		
Line #	Length	Direction
L154	11.33	S88°39'35"W
L155	21.94	S1°20'30"E
L156	15.00	S88°28'51"W
L157	21.00	S1°20'29"E
L158	2.05	S0°01'31"E
L159	15.01	N89°59'19"E
L160	14.99	S89°59'19"W
L161	5.94	S0°01'31"E
L162	15.71	S89°59'57"W
L163	8.40	S0°00'04"E
L164	8.40	N0°04'45"E
L165	15.28	N89°55'13"W
L166	8.40	S1°24'30"E
L167	7.00	N89°59'43"W
L168	4.00	S0°00'09"W
L169	7.00	N89°59'52"W
L170	4.00	S0°00'09"W
L171	10.00	S1°54'47"E
L172	12.00	N88°05'11"E
L173	10.00	S1°54'47"E
L174	7.00	S1°54'47"E
L175	16.24	N88°05'15"E

## LINE TABLE

VACATION & REPLAT OF  
HIGHLAND PARK CEMETERY PLAT &  
INCLUDING UNPLATTED PORTIONS OF THE  
N&E¼ OF SECTION 10, T.33N., R.79W., 6TH P.M.  
AS  
HIGHLAND PARK CEMETERY ADDITION NO. 2 SHEET

AN ADDITION TO THE CITY OF CASPER, WYOMING  
BEING A PORTION OF THE S&NE¼ AND THE N&E¼ OF  
SECTION 10 T.33N., R.79W., 6TH P.M.  
NATRONA COUNTY, WYOMING



Civil Engineering Professionals, Inc.  
6080 Enterprise Drive, Casper, WY 82609  
Phone 307.266.4346 Fax 307.266.0103  
www.cepi-casper.com

ORDINANCE NO. 3-21

AN ORDINANCE APPROVING THE PLAT OF THE  
HIGHLAND PARK CEMETERY ADDITION NO. 2.

WHEREAS, the City of Casper has applied for plat approval to create the Highland Park Cemetery Addition No. 2, consisting of a vacation and replat of Highland Park Cemetery, and incorporating un-platted portions of the N1/2SE1/4 of Section 10 T33N, R79W, 6<sup>th</sup> PM, Natrona County, Wyoming (the "plat"); and,

WHEREAS, after a public hearing, the City of Casper Planning and Zoning Commission passed a motion recommending that the City Council approve the requested plat; and,

WHEREAS, the final plat requires approval by ordinance, following a City Council public hearing; and,

WHEREAS, the governing body of the City of Casper finds that the above-described plat and should be approved.

NOW, THEREFORE, BE IT ORDAINED BY THE GOVERNING BODY OF THE CITY OF CASPER, WYOMING:

SECTION 1:

The final plat creating the Highland Park Cemetery Addition No. 2 is hereby approved.

SECTION 2:

This ordinance shall be in full force and effect from and after passage on three readings and publication pursuant to law.

PASSED on 1st reading the 19<sup>th</sup> day of January 2021.

PASSED on 2nd reading the \_\_\_\_ day of \_\_\_\_\_, 202\_\_.

PASSED, APPROVED, AND ADOPTED on 3rd and final reading the \_\_\_\_ day of \_\_\_\_\_, 202\_\_.



APPROVED AS TO FORM:

*Walker Trust*

---

ATTEST:

CITY OF CASPER, WYOMING  
A Municipal Corporation

---

Fleur Tremel  
City Clerk

---

Steven K. Freel  
Mayor

# Approximate Boundary of Proposed Annexation Area "East Robertson Road Addition"

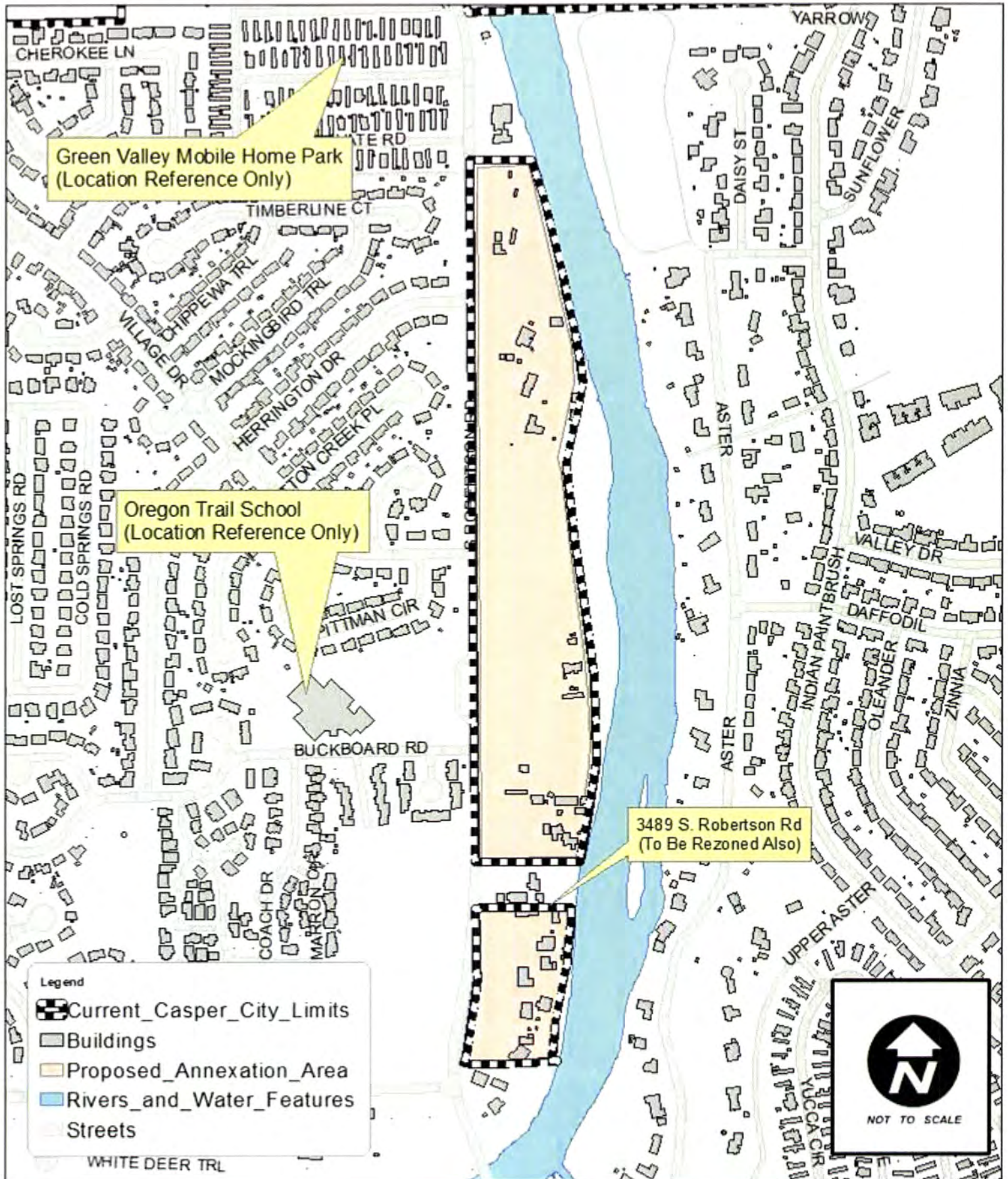

ORDINANCE NO. 4-21

AN ORDINANCE APPROVING THE CITY-INITIATED ANNEXATION OF THE EAST ROBERTSON ROAD ADDITION; AND A COUNCIL-INITIATED REZONE OF THE PROPERTY LOCATED AT 3489 SOUTH ROBERTSON ROAD

WHEREAS, the Casper City Council approved Resolution No. 20-235, initiating the annexation of the East Robertson Road Addition, consisting of fifteen (15) lots located east of Robertson Road, and north of the Robertson Road river crossing/bridge, and more particularly described in the annexation exhibit, attached hereto as Exhibit A, which is hereby incorporated into this ordinance as though fully set forth; and,

WHEREAS, the East Robertson Road Addition is one hundred percent (100%) surrounded by properties currently located within the Casper corporate limits; and,

WHEREAS, pursuant to Section 17.12.180 of the Casper Municipal Code, the City Council may impose zoning on the property to be annexed; and,

WHEREAS, the 2017 Generation Casper Comprehensive Land Use Plan supports the zoning of the property as AG (Urban Agriculture); and,

WHEREAS, an annexation report will be completed prior to third reading, and final approval of the annexation, in accordance with Section 15-1-402 of the Wyoming State Statutes, as amended; and,

WHEREAS, the City received a request from the property owner of 3489 South Robertson Road, more particularly described as Lot 1, Loraas Addition to the City of Casper, to rezone her property from R-2 (One Unit Residential) to AG (Urban Agriculture), so that the zoning of her property is consistent with the zoning of the surrounding area being annexed; and,

WHEREAS, pursuant to Section 17.12.160 of the Casper Municipal Code, the City Council may initiate zone changes.

WHEREAS, the City of Casper Community Development Director recommends the rezoning of 3489 South Robertson Road to AG (Urban Agriculture), in that the rezone will be consistent with surrounding zoning and the 2017 Generation Casper Comprehensive Land Use Plan.

NOW, THEREFORE, BE IT ORDAINED BY THE GOVERNING BODY OF THE CITY OF CASPER, WYOMING:

SECTION 1:

The annexation of the East Robertson Road Addition, as described in Exhibit A, is hereby approved, and said area is included within the corporate limits of the City of Casper and all

rights, privileges, and duties pertaining to such inclusion shall apply to said development and the inhabitants thereof.

SECTION 2:

AG (Urban Agriculture) zoning of the East Robertson Road Addition is hereby approved.

SECTION 3:

All utility franchises shall be furnished a copy of this ordinance, and other information required by the franchises, as official notice of the expansion of the City limits.

SECTION 4:

3489 South Robertson Road, more particularly described as Lot 1, Loraas Addition to the City of Casper, is hereby rezoned from R-2 (One Unit Residential) to AG (Urban Agriculture).

SECTION 5:

This ordinance shall, pursuant to W. S. § 15-1-408, be in full force and effect on the 21st business day following third reading approval by the City Council, and following publication.

PASSED on 1st reading the 19<sup>th</sup> day of January, 2021.

PASSED on 2nd reading the \_\_\_\_\_ day of \_\_\_\_\_, 20\_\_.

PASSED, APPROVED, AND ADOPTED on 3rd and final reading the \_\_\_\_\_ day of \_\_\_\_\_, 20\_\_.

APPROVED AS TO FORM:

Walker Trust

ATTEST:

CITY OF CASPER, WYOMING  
A Municipal Corporation

\_\_\_\_\_  
Fleur Tremel  
City Clerk

\_\_\_\_\_  
Steven K. Freel  
Mayor



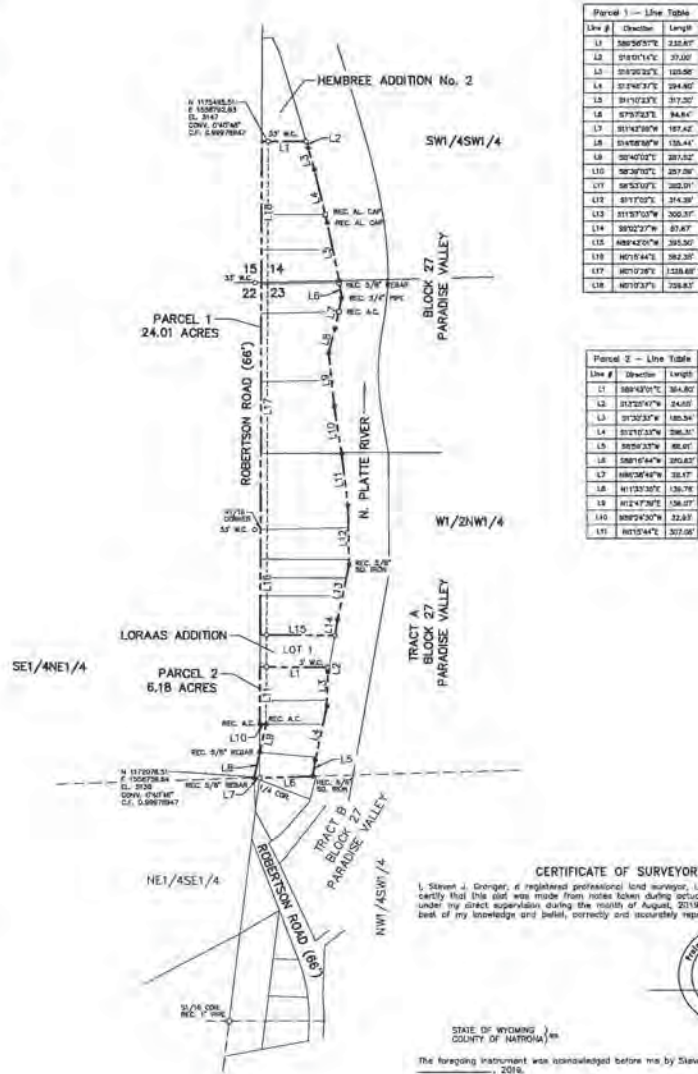
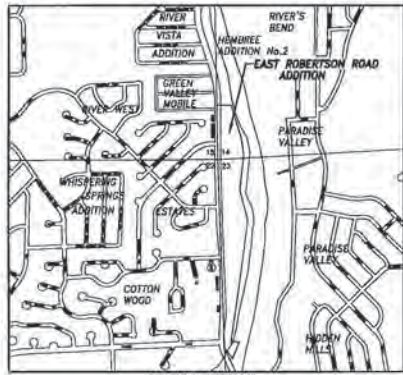

Parcel 1 - Line Table

Line #	Bearing	Length
L1	S89°50'37"E	232.67
L2	S11°14'1"E	37.00
L3	S13°20'37"E	102.00
L4	S1°46'37"E	284.60
L5	S11°10'23"E	317.50
L6	S75°52'3"E	84.64
L7	S1°14'38"W	167.42
L8	S14°58'3"W	134.44
L9	S2°47'10"E	207.02
L10	S2°36'10"E	207.02
L11	S6°53'10"E	202.01
L12	S17°10'7"E	214.38
L13	S11°37'10"W	302.31
L14	S10°27'2"W	67.67
L15	S89°42'0"W	383.50
L16	N01°14'4"E	182.30
L17	S01°12'3"E	1328.68
L18	N01°12'3"E	728.87

Parcel 2 - Line Table

Line #	Bearing	Length
L1	S89°42'0"E	384.02
L2	S13°20'37"E	24.00
L3	S1°32'37"W	108.34
L4	S17°10'7"E	286.31
L5	S05°33'3"E	86.67
L6	S89°14'4"E	202.67
L7	S89°34'4"E	207.07
L8	N11°32'3"E	136.76
L9	N12°47'3"E	158.07
L10	S89°24'2"W	22.87
L11	N01°14'4"E	307.90

## AN ANNEXATION PLAT OF THE EAST ROBERTSON ROAD ADDITION

A SUBDIVISION OF PORTIONS OF THE SW1/4SW1/4, SECTION 14,  
THE W1/2NW1/4 AND NW1/4SW1/4, SECTION 23 AND THE  
NE1/4SE1/4 AND SE1/4NE1/4, SECTION 22,  
TOWNSHIP 33 NORTH, RANGE 80 WEST  
SIXTH PRINCIPAL MERIDIAN  
NATRONA COUNTY, WYOMING  
TO THE CITY OF CASPER, WYOMING

SCALE: 1"=300'

### CERTIFICATE OF ANNEXATION AND DEDICATION

The City of Casper, Natrona County, Wyoming, through its Mayor, hereby certifies that the foregoing lands located in said being portions of the SW1/4SW1/4, Section 14, the NE1/4SE1/4 and SE1/4NE1/4, Section 22 and the W1/2NW1/4 and NW1/4SW1/4, Section 23, Township 33 North, Range 80 West of the Sixth Principal Meridian, Natrona County, Wyoming and being more particularly described by metes and bounds as follows:

Beginning of the northeastern corner of the Parcel being described, the southwestern corner of Hembree Addition No. 2 to the City of Casper, Wyoming, and a point in the westerly line of said SW1/4SW1/4, Section 14; thence from said Point of Beginning and along the northern line of said Parcel and the southern line of said Hembree Addition No. 2, into said SW1/4SW1/4, Section 14; S.89°50'37"E., 232.67 feet to the northeastern corner of said Parcel; thence southeasterly corner of said Hembree Addition No. 2 and a point in the westerly line of Block 27, Paradise Valley to the City of Casper, Wyoming; thence along the westerly line of said Parcel and the westerly line of said Block 27, Paradise Valley, into said W1/2NW1/4, Section 23, the following courses: S.1°14'38"W., 167.42 feet to a point; thence S.1°10'23"E., 317.50 feet to a point; thence S.75°52'3"E., 84.64 feet to a point; thence S.1°14'38"W., 167.42 feet to a point; thence S.14°58'3"W., 134.44 feet to a point; thence S.2°47'10"E., 207.02 feet to a point; thence S.2°36'10"E., 207.02 feet to a point; thence S.6°53'10"E., 202.01 feet to a point; thence S.17°10'7"E., 214.38 feet to a point; thence S.11°37'10"W., 302.31 feet to the southeasterly corner of said Parcel and the northwestern corner of Loraas Addition to the City of Casper, Wyoming; thence along the southerly line of said Parcel and the northern line of said Loraas Addition, N.89°42'0"W., 383.50 feet to the southeasterly corner of said Parcel, the northwestern corner of said Loraas Addition and a point in the westerly line of said W1/2NW1/4, Section 23; thence along the westerly line of said Parcel and the westerly line of said W1/2NW1/4, Section 23, N.11°32'3"E., 136.76 feet to a point; thence along the westerly line of said Parcel and the westerly line of said W1/2NW1/4, Section 23, N.12°47'3"E., 158.07 feet to a point; thence along the westerly line of said Parcel and the westerly line of said W1/2NW1/4, Section 23, N.01°12'3"E., 1328.68 feet to the southeasterly corner of said SW1/4SW1/4, Section 14; thence along the westerly line of said Parcel and the westerly line of said SW1/4SW1/4, Section 14, N.01°12'3"E., 728.87 feet to the Point of Beginning and containing 24.01 acres, more or less.

Beginning of the northwestern corner of the Parcel being described, the southwestern corner of Loraas Addition to the City of Casper, Wyoming and a point in the westerly line of said W1/2NW1/4, Section 23; thence along the northern line of said Parcel and the southern line of said Loraas Addition, into said W1/2NW1/4, Section 23, N.89°42'0"E., 384.02 feet to the northwestern corner of said Parcel, the southeasterly corner of said Loraas Addition and a point in the westerly line of Block 27, Paradise Valley, to the City of Casper, Wyoming; thence along the westerly line of said Parcel and the westerly line of said Block 27, Paradise Valley the following courses: S.13°20'37"W., 24.00 feet to a point; thence S.1°32'37"W., 108.34 feet to a point; thence S.17°10'7"E., 286.31 feet to a point; thence S.5°33'3"W., 86.67 feet to a point; thence S.89°14'4"W., 202.67 feet to the southeasterly corner of said Parcel and a point in the southern line of said W1/2NW1/4, Section 23; thence along the southerly line of said Parcel and the southerly line of said W1/2NW1/4, Section 23, S.89°34'4"E., 207.07 feet to the southeasterly corner of said SE1/4NE1/4, Section 22; thence along the southerly line of said Parcel and the southerly line of said SE1/4NE1/4, Section 22, N.89°34'4"W., 207.07 feet to the southwesterly corner of said Parcel and a point in the westerly line of said Robertson Road, thence along the westerly line of said Parcel and westerly line of said Robertson Road, corner said SE1/4NE1/4, Section 22, N.11°32'3"E., 136.76 feet to a point in the westerly line of said W1/2NW1/4, Section 23; thence along the westerly line of said Parcel and the westerly line of said Robertson Road, into said W1/2NW1/4, Section 23, N.12°47'3"E., 158.07 feet to a point; thence along the westerly line of said Parcel and the westerly line of said W1/2NW1/4, Section 23; thence along the westerly line of said Parcel and the westerly line of said W1/2NW1/4, Section 23, N.01°12'3"E., 1328.68 feet to the Point of Beginning and containing 4.48 acres, more or less.

The maps on appears on this Plat, was duly annexed into the corporate boundaries of the City of Casper, Natrona County, Wyoming pursuant to the land annexation under the provisions of Section 15-1-101 et. seq. of the Wyoming State Statutes, 1977, as amended and after Notice and Public Hearing, City Ordinance Number \_\_\_\_\_, was passed and applied on final reading on the \_\_\_\_\_ day of \_\_\_\_\_, 2019, according to the land described in annexed to the City of Casper, Wyoming, the annexation as named above and Robertson Road as shown on the Plat has previously been dedicated as a public road.

Dated this \_\_\_\_\_ day of \_\_\_\_\_, 2019.  
CITY OF CASPER, NATRONA COUNTY, WYOMING  
200 N. DAVID STREET  
CASPER, WYOMING 82401

**CERTIFICATE OF SURVEYOR**  
I, Steven J. Granger, a registered professional land surveyor, License No. 15082, do hereby certify that this plat was made from notes taken during actual surveys made by me or under my direct supervision during the month of August, 2019 and that this plat, to the best of my knowledge and belief, correctly and accurately represents said surveys.

STATE OF WYOMING  
COUNTY OF NATRONA

The foregoing instrument was acknowledged before me by Steven J. Granger this \_\_\_\_\_ day of \_\_\_\_\_, 2019.  
Witness my hand and official seal.  
My commission expires: \_\_\_\_\_ Notary Public

**APPROVALS**  
APPROVED: City Council of the City of Casper, Wyoming this \_\_\_\_\_ day of \_\_\_\_\_, 2019.  
Attest: \_\_\_\_\_ Mayor  
INSPECTED AND APPROVED on the \_\_\_\_\_ day of \_\_\_\_\_, 2019.  
City Engineer  
INSPECTED AND APPROVED on the \_\_\_\_\_ day of \_\_\_\_\_, 2019.  
City Surveyor

PLAT CLOSURE RATIO EXCEEDS PARCEL 1 - 1:1,194,672  
PARCEL 2 - 1:272,141

DATA:  
GROUND DISTANCE - U.S. FOOT  
BASIS OF BEARING - GEODETIC BASIS ON GPS  
COORDINATES REFER TO CITY OF CASPER UG DATUM,  
WYOMING STATE PLANE COORDINATES, EAST CENTRAL ZONE, NAD83/86  
ELEVATIONS ARE FOR REFERENCE ONLY AND NOT FOR USE AS A BENCHMARK

**LEGEND**  
 ■ RECOVERED BRASS CAP  
 □ RECOVERED CORNER (AS NOTED)  
 \* SET BRASS CAP  
 W.C. WITNESS CORNER  
 --- SUBDIVISION BOUNDARY  
 --- EASEMENT  
 --- MEASURED BEARING & DISTANCE  
 --- RECORDED BEARING & DISTANCE

N.84°33'50"E., 469.86'  
N.81°01'42"E., 392.18'



January 13, 2021

MEMO TO: J. Carter Napier, City Manager *JCN*

FROM: Andrew Beamer, P.E., Public Services Director *AB*  
Ethan Yonker, P.E., Associate Engineer

SUBJECT: Authorizing an Agreement with Crown Construction, LLC, in the Amount of \$209,044.00, for the Recycle Depot Improvements, Project No. 16-004

**Meeting Type & Date**

Regular Council Meeting  
February 2, 2021

**Action Type**

Resolution

**Recommendation**

That Council, by resolution, authorize an Agreement with Crown Construction, LLC, in the Amount of \$209,044.00, for the Recycle Depot Improvements, Project No. 16-004. Furthermore, it is recommended that Council authorize a construction contingency account in the amount of \$31,400.00, for a total project amount of \$240,444.00

**Summary**

This project is for improvements to recycle depots at several locations in Casper; Paradise Valley Pool site, Mike Sedar Pool site, Ice Arena site, and the Viking Court site. The work includes removal of existing surfacing, grading, installation of concrete curbwalk, fencing, and surfacing.

The bids received for this work are as follows:

<u>CONTRACTOR</u>	<u>BUISNESS LOCATION</u>	<u>BID AMOUNT</u>
<b>Crown Construction</b>	<b>Mills, Wyoming</b>	<b>\$284,459.00</b>
Wayne Coleman Construction	Mills, Wyoming	\$298,307.00
Installation and Service Company	Mills, Wyoming	\$304,352.19
Treto Construction	Casper, Wyoming	\$310,755.00
Andreen Hunt Construction	Casper, Wyoming	\$332,336.00
JTL Group, dba Knife River	Casper, Wyoming	\$361,700.61
Ramshorn Construction	Casper, Wyoming	\$441,995.00
71 Construction	Casper, Wyoming	\$449,891.41

By State Statute, all in-state bidders receive a five percent (5%) bid preference. The in-state preference does not impact the outcome of the low bidder, as the low bidder was an in-state bidder.

Work is scheduled to be completed by June 30, 2021, and July 10, 2021, for substantial and final completion respectively. The estimate prepared by the City Engineering Department was \$288,710.00.

**Financial Considerations**

The budget available for the project is \$256,500.00 from Refuse Collections. Due to budget limitations, the Ice Arena site is being removed from the project for a reduction of \$81,175.00. The alternate item installing concrete mow bands at the base of the fencing (\$5,760.00) is being included for a total contract amount of \$209,044.00

**Oversight/Project Responsibility**

Ethan Yonker, P.E., Associate Engineer, Public Services

**Attachments**

Resolution

Agreement



STANDARD FORM OF  
AGREEMENT BETWEEN OWNER AND CONTRACTOR

THIS AGREEMENT is made between the City of Casper, Wyoming, 200 North David Street, Casper, Wyoming 82601, hereinafter referred to as the "Owner," and with Crown Construction, LLC, PO Box 664, Mills, Wyoming 82644, hereinafter referred to as the "Contractor."

WHEREAS, the City of Casper desires to improve recycle depots at 4 locations in Casper; and,

WHEREAS, Crown Construction, LLC, is able and willing to provide those services specified as the RECYCLE DEPOT IMPROVEMENTS, Project 16-004.

NOW, THEREFORE, it is hereby agreed as follows:

ARTICLE 1. WORK.

Contractor shall perform all the work required by the Contract Documents for the RECYCLE DEPOT IMPROVEMENTS, Project 16-004.

ARTICLE 2. ENGINEER.

The Project has been designed by the City of Casper Engineering Department who is hereinafter referred to as the "Engineer" and who is to act as an Owner's representative, assume all duties and responsibilities and have the rights and authority assigned to Engineer in the Contract Documents in connection with completion of the Work in accordance with the Contract Documents.

ARTICLE 3. CONTRACT TIME.

Work will be considered substantially complete when all concrete, pavement, irrigation, electrical, mechanical, and landscaping work has been completed. Final completion will be granted upon completion of a walk through with Owner's Representative, completion of punchlist, clean up of work site, and de-mobilization.

- 3.1 The Work will be substantially completed by May 28, 2021, and completed and ready for final payment in accordance with Paragraph 14.13 of the General Conditions by June 11, 2021.
- 3.2 Liquidated Damages. Owner and Contractor recognize that time is of the essence of this Agreement and that Owner will suffer financial loss if the Work is not substantially completed by the time specified in Paragraph 3.1 above, plus any extension thereof allowed in accordance with Article 12 of the General Conditions. They also recognize the delays, expense, and difficulties involved in proving in a legal or arbitration proceeding the actual loss suffered by Owner if the Work is not substantially completed on time. Accordingly,

instead of requiring any such proof, Owner and Contractor agree that as liquidated damages for delay (but not as a penalty) Contractor shall pay Owner Seven Hundred Fifty Dollars (\$750.00) for each day that expires after the time specified in Paragraph 3.1 for substantial completion. After Substantial Completion, if Contractor shall neglect, refuse, or fail to complete the remaining work within the time specified in paragraph 3.1 for completion and readiness for final payment or any proper extension thereof granted by Owner, Contractor shall pay Owner Two Hundred Fifty Dollars (\$250.00) for each day that expires after the time specified in paragraph 3.1 for completion and readiness for final payment. It is further agreed that such liquidated damages are not a penalty, but represent the parties' best estimate of actual damages.

#### ARTICLE 4. CONTRACT PRICE.

Owner shall pay Contractor in current funds for performance of the Work in accordance with the Contract Documents, subject to additions and deductions by Change Order, the contract price of Two Hundred Nine Thousand Forty-Four and 00/100 Dollars (\$209,044.00). See Exhibit "A" – Bid Form and Bid Schedule.

#### ARTICLE 5. PAYMENT PROCEDURES.

Contractor shall submit Applications for Payment in accordance with Article 14 of the General Conditions. Applications for Payment will be processed through the Engineer as provided in the General Conditions.

- 5.1 Progress Payments. Owner shall make progress payments on the basis of Contractor's Applications for Payment as recommended by Engineer, on or about the 25th day of each month during construction as provided below. All progress payments will be on the basis of the progress of the Work measured by the Schedule of Values provided for in Paragraph 14.1 of the General Conditions, subject to the cutoff and submittal dates provided in the General Provisions.
  - 5.1.1 Progress payments will be made in an amount equal to 95% of the Work completed, and 95% of Invoice Cost of materials and equipment not incorporated in the Work but delivered and suitably stored, less in each case the aggregate of payments previously made.
  - 5.1.2 Owner shall withhold five percent (5%) of the work completed as retainage, said retainage to be paid in accordance with the provisions of Paragraph 5.2, Final Payment.
  - 5.1.3 Should amounts owed by the Contractor to the City for any goods, services, licenses, permits or any other item or purpose remain unpaid beyond the City's general credit policy, those amounts may be deducted from the payment being made by the City to the Contractor pursuant to this agreement.

- 5.2 Final Payment. Upon final completion and acceptance of the Work in accordance with Paragraph 14.13 of the General Conditions, Engineer shall recommend payment and present Contractor's Final Application for Payment to the City. Pursuant to Wyoming State Statutes, final payment cannot be made until forty-one (41) days after publication of the first Notice of Completion.

#### ARTICLE 6. WITHHELD FUNDS.

Pursuant to Wyoming Statutes Section 16-6-701 et seq., withheld percentages for Contracts exceeding Twenty-Five Thousand and 00/100 Dollars (\$25,000.00) will be retained in an account in the name of the Contractor (except when specifically waived in writing by Contractor) which has been assigned to the Owner until the Contract is completely, satisfactorily, and finally accepted by the Owner. Unless a depository is designated by the Contractor in a written attachment hereto, the Contractor's signature hereon shall act as authority for the Owner to designate a retainage depository on behalf of the Contractor, for the purposes specified in Wyoming Statutes Section 16-6-704. The Contractor's signature hereon shall act as an assignment of the depository account to the Owner, as provided by Wyoming Statutes Section 16-6-701 et seq., whether the depository is designated by the Contractor or by the Owner.

#### ARTICLE 7. CONTRACTOR'S REPRESENTATIONS.

In order to induce Owner to enter into this Agreement, Contractor makes the following representations:

- 7.1 Contractor has familiarized himself with the nature and extent of the Contract Documents, Work, locality, and with all local conditions and federal, state, and local Laws and Regulations that in any manner may affect cost, progress, or performance of the Work.
- 7.2 Contractor has studied carefully all reports of investigations and test of subsurface and latent physical conditions at the site or otherwise affecting cost, progress, or performance of the work which were relied upon by Engineer in the preparation of the Drawings and Specifications and which have been identified in the Supplementary Conditions.
- 7.3 Contractor has made or caused to be made examinations, investigations, and test and studies as he deems necessary for the performance of the Work at the Contract Price, within the Contract Time, and in accordance with the other terms and conditions of the Contract Documents; and no additional examinations, investigations, tests, reports, or similar data are or will be required by Contractor for such purposes.
- 7.4 Contractor has correlated the results of all such observations, examinations, investigations, tests, reports, and data with the terms and conditions of the Contract Documents.
- 7.5 Contractor has given Engineer written notice of all conflicts, errors, or discrepancies that he has discovered in the Contract Documents and the written resolution thereof by Engineer is acceptable to Contractor.

7.6 Contractor certifies that materials containing asbestos will not be used for this project without prior written approval by the Owner.

#### ARTICLE 8. CONTRACT DOCUMENTS.

The Contract Documents which comprise the entire agreement between Owner and Contractor are attached to this Agreement, made a part hereof and consist of the following:

- 8.1 This Agreement (Pages SFA-1 to SFA-5, inclusive).
- 8.2 Exhibit "A" - Bid Form and Bid Schedule (BF-1 through BF-4 and BS-1).
- 8.3 Joint Account Agreement or Letter of Forfeiture waiving same.
- 8.4 Addenda No. 3.
- 8.5 Performance and Payment Bonds.
- 8.6 Certificates of Insurance, of Workers' Compensation Coverage, and of Unemployment Insurance Coverage.
- 8.7 Notice of Award.
- 8.8 Notice to Proceed.
- 8.9 Minutes of the Pre-Bid Conference, if any.
- 8.10 General Conditions (Pages 00700-1 to 00700-42, inclusive).
- 8.11 Supplementary Conditions (Pages SSC-1 to SSC-15, inclusive).
- 8.12 Technical Specifications, consisting of six (6) sections.
- 8.13 Special Provisions, consisting of eleven (11) sections
- 8.14 Contract Drawings, consisting of three (3) Sheets
- 8.15 Shop Drawings and other Submittals furnished by Contractor during performance of the Work and accepted by the Owner.
- 8.16 Any modifications, amendments, and supplements, including Change Orders, issued pursuant to Paragraphs 3.4 and 3.5 of the General Conditions, on or after the effective date of this Agreement.

8.17 Notice of Substantial Completion.

ARTICLE 9. GOVERNMENTAL CLAIMS ACT

The Owner does not waive any right or rights it may have pursuant to the Wyoming Governmental Claims Act, Wyoming Statutes Section 1-39-101 et seq. The Owner specifically reserves the right to assert any and all immunities, rights, and defenses it may have pursuant to the Wyoming Governmental Claims Act.

ARTICLE 10. MISCELLANEOUS PROVISIONS.

Terms used in this Agreement, which are defined in the General Conditions, shall have the meanings designated in those conditions.

IN WITNESS WHEREOF, the parties hereto have caused this Agreement to be executed in one (1) original copy on the day and year first above written.

DATED this \_\_\_\_\_ day of \_\_\_\_\_, 2021.

APPROVED AS TO FORM:  
(Recycle Depot Improvements, Project 16-004)

*Walter Tremel*

ATTEST:

By: \_\_\_\_\_

Title: \_\_\_\_\_

ATTEST:

By: \_\_\_\_\_

Fleur Tremel  
Title: City Clerk

CONTRACTOR:

By: \_\_\_\_\_

Title: \_\_\_\_\_

OWNER:  
CITY OF CASPER, WYOMING  
A Municipal Corporation

By: \_\_\_\_\_

Steven K. Freel  
Title: Mayor

**EXHIBIT "A"**  
**STANDARD**  
**BID FORM**  
(Approved by City Attorney, 1995)

**PROJECT IDENTIFICATION:** City of Casper  
Recycle Depot Improvements, Project 16-004

**THIS BID SUBMITTED TO:** City of Casper  
200 North David Street  
Casper, Wyoming 82601

1. The undersigned Bidder proposes and agrees, if this Bid is accepted, to enter into an Agreement with the City in the form included in the Bidding Documents and to complete all Work as specified or indicated in the Bidding Documents for the Contract Price by June 30, 2021, and completed and ready for final payment not later than July 10, 2021, in accordance with the Bidding Documents.
2. Bidder accepts all of the terms and conditions of the Advertisement for Bids and Instructions to Bidders, including without limitation those dealing with the disposition of Bid Guaranty. This Bid will remain effective for thirty (30) days after the day of Bid opening. Bidder will sign the Agreement and submit the Bonds and other documents required by the Bidding Documents within thirty (30) days after the date of the City's Notice of Award.
3. Notice that preferences will be granted pursuant to Wyoming Statutes Section 16-6-101, et seq., is hereby acknowledged.
4. In submitting this Bid, Bidder represents, as more fully set forth in the Bidding Documents, that:
  - A. Bidder has examined copies of all the Bidding Documents and of the following addenda (receipt of all which is hereby acknowledged):

Addendum No. <u>#1</u>	Dated <u>1-6-2021</u>
Addendum No. <u>#2</u>	Dated <u>1-7-2021</u>
<u>#3</u>	<u>1-8-2021</u>
  - B. Bidder has examined the site and locality where the work is to be performed, the federal, state, and local Laws and Regulations, and the conditions affecting cost, progress, or performance of the work and has made such independent investigations as Bidder deems necessary;
  - C. This Bid is genuine and not made in the interest of or on behalf of any undisclosed person, firm, corporation, or other business entity. Bidder has not directly or indirectly induced or solicited any other Bidder to submit a false or sham Bid. Bidder



has not solicited or induced any person, firm, or a corporation to refrain from bidding. Bidder has not sought by collusion to obtain for itself any advantage over any other Bidder or against the City.

5. Bidder is bidding all schedules, alternates, if any, and will complete the Work for unit price(s) stated on the attached bid schedule based on materials actually furnished and installed and services actually provided. The Bid is summarized below on the basis of estimated quantities:

TOTAL BASE BID, IN NUMERALS: \$ 284,459.00

TOTAL BASE BID, IN WORDS: Two hundred eighty four thousand four hundred fifty nine DOLLARS.

6. Bidder agrees that the work for the City will be as provided above.
7. Bidder accepts the provisions of the Bidding Documents as to liquidated damages in the event of failure to complete the work on time, unless otherwise stated as provided below. Bidder agrees that such liquidated damages are not a penalty and that the amount provided is as close an estimate as possible to actual damages. Any exceptions or objections to this provision are stated in writing and attached hereto by Bidder.
8. The following documents are attached to and made a condition of this Bid:
- A. Required Bid Guaranty in the form of a Bid Bond. (Unless otherwise provided by the City.)
  - B. Itemized Bid Schedule.

9. Communications concerning this Bid shall be addressed to:

Address of Bidder: Crown Construction  
P.O. Box 1664  
Mills, WY 82644

10. The terms used in this Bid are defined in and have the meanings assigned to them in the General Conditions, except as provided in the Supplementary Conditions and Bidding Documents.

Submitted on 11/2/2021, 2020.

Bidder is bidding as a Resident (Insert Resident or Non-Resident)

IF BIDDER IS:



A CORPORATION OR LIMITED LIABILITY COMPANY

By: Crown Construction LLC (seal)  
(Corporation's or Limited Liability Company's Name)

Wyoming  
(State of Incorporation or Organization)

By: gk owner  
(Title)

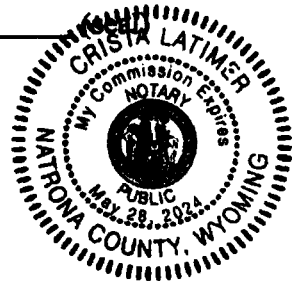

(Seal)

Attest: Crista Latimer 1/12/2021

Business Address: PO Box 664  
Mill. WY 82644

Phone Number: 307-337-7069

A JOINT VENTURE

By: \_\_\_\_\_ (seal)  
(Name)

\_\_\_\_\_  
(Address)

By: \_\_\_\_\_ (seal)  
(Name)

\_\_\_\_\_  
(Address)

(Each joint venturer must sign. The manner of signing for each individual, partnership, and corporation that is a party to the joint venture should be in the manner indicated above.)

**Bid Schedule**

Recycle Depot Installations (#7387360)

Owner: Casper WY, City of

Solicitor: Casper WY, City of

01/12/2021 04:00 PM MST

				Crown Construction				
Section	Titl	Line Item	Item Code	Item Description	UofM	Quantity	Unit Price	Extension
								\$47,760.00
<b>Paradise Valley</b>								
		PV 1	Bid Item 1	Mobilization and Bonding	LS	1	\$2,000.00	\$2,000.00
		PV 2	Bid Item 2	Traffic Control	LS	1	\$500.00	\$500.00
		PV 3	Bid Item 3	Grading	LS	1	\$1,000.00	\$1,000.00
		PV 4	Bid Item 4	Demo and Site Preperation	LS	1	\$2,500.00	\$2,500.00
		PV 5	Bid Item 5	F&I 4" Asphalt over 6" Base	SY	85	\$37.00	\$3,145.00
		PV 6	Bid Item 6	F&I 8" Concrete over 4" Crushed Base	SY	125	\$72.00	\$9,000.00
		PV 7	Bid Item 7	F&I 6' Black Vinyl Coated Chainlink Fence	LF	60	\$34.00	\$2,040.00
		PV 8	Bid Item 8	F&I 12' Black Vinyl Coated Chainlink Fence	LF	110	\$86.00	\$9,460.00
		PV 9	Bid Item 9	F&I 4" Wide Striping	LS	1	\$1,000.00	\$1,000.00
		PV 11	Bid Item 11	F&I Concrete Valley Gutter	SY	70	\$72.00	\$5,040.00
		PV 14	Bid Item 14	F&I 30" Type B Curb and Gutter	LF	45	\$85.00	\$3,825.00
		PV 15	Bid Item 15	F&I 3" Caliper Tree	EA	3	\$750.00	\$2,250.00
		PV 18	Bid Item 18	Unclassified Excavation	CY	200	\$15.00	\$3,000.00
		PV 19	Bid Item 19	Select Backfill	CY	200	\$10.00	\$2,000.00
		PV 20	Bid Item 20	Soil Stabilization Fabric	SY	100	\$10.00	\$1,000.00
								\$75,350.00
<b>Mike Sedar</b>								
		MS 1	Bid Item 1	Mobilization and Bonding	LS	1	\$2,000.00	\$2,000.00
		MS 2	Bid Item 2	Traffic Control	LS	1	\$500.00	\$500.00
		MS 3	Bid Item 3	Grading	LS	1	\$1,000.00	\$1,000.00
		MS 4	Bid Item 4	Demo and Site Preperation	LS	1	\$1,000.00	\$1,000.00
		MS 5	Bid Item 5	F&I 4" Asphalt over 6" Base	SY	1050	\$37.00	\$38,850.00
		MS 6	Bid Item 6	F&I 8" Concrete over 4" Crushed Base	SY	125	\$72.00	\$9,000.00
		MS 8	Bid Item 8	F&I 12' Black Vinyl Coated Chainlink Fence	LF	200	\$80.00	\$16,000.00
		MS 9	Bid Item 9	F&I 4" Wide Striping	LS	1	\$1,000.00	\$1,000.00
		MS 18	Bid Item 18	Unclassified Excavation	CY	200	\$15.00	\$3,000.00
		MS 19	Bid Item 19	Select Backfill	CY	200	\$10.00	\$2,000.00
		MS 20	Bid Item 20	Soil Stabilization Fabric	SY	100	\$10.00	\$1,000.00
								\$81,175.00
<del>CATC</del>								
		<del>CATC 1</del>	<del>Bid Item 1</del>	<del>Mobilization and Bonding</del>	<del>LS</del>	<del>1</del>	<del>\$2,000.00</del>	<del>\$2,000.00</del>
		<del>CATC 2</del>	<del>Bid Item 2</del>	<del>Traffic Control</del>	<del>LS</del>	<del>1</del>	<del>\$500.00</del>	<del>\$500.00</del>
		<del>CATC 3</del>	<del>Bid Item 3</del>	<del>Grading</del>	<del>LS</del>	<del>1</del>	<del>\$1,000.00</del>	<del>\$1,000.00</del>
		<del>CATC 5</del>	<del>Bid Item 5</del>	<del>F&amp;I 4" Asphalt over 6" Base</del>	<del>SY</del>	<del>1250</del>	<del>\$37.00</del>	<del>\$46,250.00</del>
		<del>CATC 6</del>	<del>Bid Item 6</del>	<del>F&amp;I 8" Concrete over 4" Crushed Base</del>	<del>SY</del>	<del>125</del>	<del>\$72.00</del>	<del>\$9,000.00</del>
		<del>CATC 8</del>	<del>Bid Item 8</del>	<del>F&amp;I 12' Black Vinyl Coated Chainlink Fence</del>	<del>LF</del>	<del>200</del>	<del>\$68.00</del>	<del>\$13,600.00</del>
		<del>CATC 16</del>	<del>Bid Item 16</del>	<del>F&amp;I Post and Cable Fence</del>	<del>LF</del>	<del>85</del>	<del>\$25.00</del>	<del>\$2,125.00</del>
		<del>CATC 17</del>	<del>Bid Item 17</del>	<del>F&amp;I Concrete Manhole Diamond</del>	<del>EA</del>	<del>1</del>	<del>\$700.00</del>	<del>\$700.00</del>
		<del>CATC 18</del>	<del>Bid Item 18</del>	<del>Unclassified Excavation</del>	<del>CY</del>	<del>200</del>	<del>\$15.00</del>	<del>\$3,000.00</del>
		<del>CATC 19</del>	<del>Bid Item 19</del>	<del>Select Backfill</del>	<del>CY</del>	<del>200</del>	<del>\$10.00</del>	<del>\$2,000.00</del>
		<del>CATC 20</del>	<del>Bid Item 20</del>	<del>Soil Stabilization Fabric</del>	<del>SY</del>	<del>100</del>	<del>\$10.00</del>	<del>\$1,000.00</del>
								<del>\$80,174.00</del>
<b>Viking Court</b>								
		VC 1	Bid Item 1	Mobilization and Bonding	LS	1	\$2,000.00	\$2,000.00
		VC 2	Bid Item 2	Traffic Control	LS	1	\$500.00	\$500.00
		VC 3	Bid Item 3	Grading	LS	1	\$2,500.00	\$2,500.00
		VC 5	Bid Item 5	F&I 4" Asphalt over 6" Base	SY	1400	\$37.00	\$51,800.00
		VC 6	Bid Item 6	F&I 8" Concrete over 4" Crushed Base	SY	125	\$72.00	\$9,000.00
		VC 7	Bid Item 7	F&I 6' Black Vinyl Coated Chainlink Fence	LF	150	\$31.00	\$4,650.00
		VC 12	Bid Item 12	F&I Concrete Approach	SY	42	\$72.00	\$3,024.00
		VC 17	Bid Item 17	F&I Concrete Manhole Diamond	EA	1	\$700.00	\$700.00
		VC 18	Bid Item 18	Unclassified Excavation	CY	200	\$15.00	\$3,000.00
		VC 19	Bid Item 19	Select Backfill	CY	200	\$10.00	\$2,000.00
		VC 20	Bid Item 20	Soil Stabilization Fabric	SY	100	\$10.00	\$1,000.00
								\$5,760.00
<b>Alternate</b>								
		A 1	Alternate 1	F&I 1' Wide 4" Thick Concrete Curb	LF	720	\$8.00	\$5,760.00
<b>Base Bid Total:</b>								<b>\$209,044.00</b>

RESOLUTION NO.21-13

A RESOLUTION AUTHORIZING AN AGREEMENT WITH CROWN CONSTRUCTION, LLC, FOR THE RECYCLE DEPOT IMPROVEMENTS, PROJECT NO. 16-004.

WHEREAS, the City of Casper desires to enter into a contract for improvements to recycle depots at various locations in Casper; and,

WHEREAS, Crown Construction, LLC, is able and willing to provide those services specified as the Recycle Depot Improvements, Project No. 16-004; and,

WHEREAS, it would be in the best interest of the City to expedite changes in the project by allowing the City Manager to sign change orders effecting time extensions of no more than thirty (30) days, dollar amount changes no greater than Thirty-One Thousand Four Hundred and 00/100 Dollars (\$31,400.00) and other project administration related change orders that do not substantially alter the scope of the project.

NOW, THEREFORE, BE IT RESOLVED BY THE GOVERNING BODY OF THE CITY OF CASPER, WYOMING: That the Mayor is hereby authorized and directed to execute, and the City Clerk to attest, an agreement with Crown Construction, LLC, for those services, in the amount of Two Hundred Nine Thousand Forty-Four and 00/100 Dollars (\$209,044.00).

BE IT FURTHER RESOLVED: That the City Manager is hereby authorized to make verified partial payments and contract extensions throughout the project, retaining those amounts prescribed by the agreement, equal to an amount not to exceed Two Hundred Nine Thousand Forty-Four and 00/100 Dollars (\$209,044.00) and Thirty-One Thousand Four Hundred and 00/100 Dollars (\$31,400.00) for a construction contingency account, for a total price of Two Hundred Forty Thousand Four Hundred Forty-Four and 00/100 Dollars (\$240,444.00).

BE IT FURTHER RESOLVED: That the City Manager is hereby authorized to sign change orders effecting time extensions of no more than thirty (30) days, changes in the dollar amount of the above described agreement not greater than the sum of Thirty-One Thousand Four Hundred and 00/100 Dollars (\$31,400.00), and other project administration related change orders that do not substantially alter the scope of the project.

PASSED, APPROVED, AND ADOPTED this \_\_\_\_ day of \_\_\_\_\_, 2021.

APPROVED AS TO FORM:

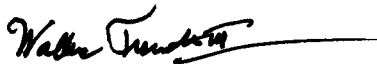

ATTEST:

CITY OF CASPER, WYOMING  
A Municipal Corporation

\_\_\_\_\_  
Fleur Tremel  
City Clerk

\_\_\_\_\_  
Steven K. Freel  
Mayor

January 14, 2021

**MEMO TO:** J. Carter Napier, City Manager *JCN*  
**FROM:** Keith McPheeters, Police Chief *KMP 307*  
Shane Chaney, Police Captain *SC*  
**SUBJECT:** Acceptance of the Drug Enforcement Agency Letter of Agreement Award

**Meeting Type & Date**

Regular Council Meeting  
February 2, 2021

**Action type**

Resolution

**Recommendation**

That Council, by resolution, authorize acceptance of funds awarded from the Drug Enforcement Administration, in the amount of Thirty Five Thousand Dollars (\$35,000), to be used for overtime reimbursement of officers that are directly involved in the eradication and suppression of illicit cannabis.

**Summary**

The Casper Police Department has been notified that the Drug Enforcement Agency, desires to award the City of Casper funds in the amount of Thirty-Five Thousand Dollars (\$35,000.00) to be used for existing salaries and other services covered by the award monies. This award is for the time period of October 1, 2020 through September 30, 2021.

**Financial Consideration**

Funding will come from the Drug Enforcement Administration of the United States Department of Justice.

**Oversight/Project Responsibility**

Captain Shane Chaney

**Attachments**

Contract  
Resolution



**U.S. Department of Justice  
Drug Enforcement Administration**

[www.dea.gov](http://www.dea.gov)

Springfield, Virginia 22152

Agreement Number 2021-114

This Letter of Agreement (LOA) is entered into between the **CASPER POLICE DEPARTMENT**, hereinafter referred to as (**THE AGENCY**), and the DRUG ENFORCEMENT ADMINISTRATION (DEA) OF THE UNITED STATES DEPARTMENT OF JUSTICE (DOJ), hereinafter referred to as DEA, in reference to the following:

There is evidence that trafficking in marijuana (illicit cannabis) has a substantial and detrimental effect on the health and general welfare of the people of the *State of Wyoming*. The parties hereto agree that it is to their mutual benefit to cooperate in locating and eradicating illicit cannabis plants and to investigate and prosecute those cases before the courts of the United States (U.S.) and the courts of the *State of Wyoming*. DEA, pursuant to the authority of 21 U.S.C. § 873, proposes to provide certain necessary funds and **THE AGENCY** is desirous of securing funds.

As used in this Letter of Agreement, the terms "marijuana" and "illicit cannabis" only refer to cannabis or cannabis-derived materials that contain more than 0.3% delta-9-THC on a dry weight basis, in accordance with the definition of marihuana in the Controlled Substances Act (21 U.S.C. § 802(16)), as amended by the Agriculture Improvement Act of 2018, Pub. L. 115-334.

NOW, therefore, in consideration of the mutual covenants hereinafter contained, the parties hereto have agreed as follows:

1. **THE AGENCY** will, with its own law enforcement personnel and employees, as hereinafter specified, perform the activities and duties described below:
  - a. Gather and report intelligence data relating to the illicit cultivation, possession, and distribution of illicit cannabis.
  - b. Investigate and report instances involving the trafficking in controlled substances.
  - c. Provide law enforcement personnel for the eradication of illicit cannabis located within the *State of Wyoming*.
  - d. Make arrests and refer to the appropriate prosecutorial authority cases for prosecution under controlled substances laws and other criminal laws.
  - e. Send required samples of eradicated illicit cannabis to the National Institute on Drug Abuse (NIDA) Potency Monitoring Project.



- f. **MANDATORY requirement for *THE AGENCY* to utilize the Web-based DEA internet Capability Endeavor(DICE) or if applicable the Firebird based DEA Analysis/Response Tracking System (DARTS) to report all statistics and seizures per incident, to include the submission of significant items for de-confliction and information sharing purposes.**
  - g. Submit electronically the signed "State/Local Agency DCE/SP Monthly Accounting Form" (DEA DCE/SP monthly expenditure report) with a copy of ***THE AGENCY's*** general ledger to the DEA Regional Contractor. If applicable, attached an invoice reflecting the expenditures for equipment in excess of \$2,500.00, which was previously approved by DEA Headquarters, and the expenses associated with the rental of leasing of vehicles or aircraft. When overtime is claimed the officer's name, date worked, hours worked, and rate of pay are REQUIRED. NOTE: Monthly "zero expenditures" are also required.
2. It is understood and agreed by the parties to this Agreement that the activities described in Sub-paragraphs a, b, c, d, e, f, and g of paragraph one (§1) shall be accomplished with existing personnel, and that the scope of ***THE AGENCY's*** program with respect to those activities by such personnel shall be solely at ***THE AGENCY's*** discretion, subject to appropriate limitations contained in the budget adopted by ***THE AGENCY***, except that ***THE AGENCY*** understands and agrees that DEA funds and the result of expended funds (e.g., equipment, supplies and other resources) must be directly related to and must only be used for marijuana eradication program activities in a manner consistent with the Controlled Substances Act (CSA), 21 U.S.C. § 801 et seq.
  3. DEA will pay to ***THE AGENCY*** Federal funds in the amount of **THIRTY FIVE THOUSAND DOLLARS (\$35,000.00)** for the period of October 1, 2020 to September 30, 2021, to defray costs relating to the eradication and suppression of illicit cannabis. These Federal funds shall only be used for the eradication of illicit cannabis as provided in this agreement. ***THE AGENCY*** understands and agrees that Federal funds provided to ***THE AGENCY*** under this Agreement will not be used to defray costs relating to herbicidal eradication of illicit cannabis without the advance written consent of DEA. DCE/SP funding is provided for the storage, protection, and destruction of illicit cultivated marijuana. Funding is not provided nor expenditures allowed for the development of technology to assist with the identification of indoor and/or outdoor growing sites. Additionally, funding and expenditures are not permitted for the eradication of "ditch weed".

***THE AGENCY*** understands and agrees that Federal funds will not be used to perform any of the following functions: (i) issuing licenses, permits, or other forms of authorization permitting the holder to manufacture, distribute, sell, or use marijuana in contravention of the CSA; (ii) conducting ancillary activities related to the issuance of such licenses and permits, such as background checks on applicants; (iii) collecting state or local tax or licensing revenue related to the manufacture, distribution, or sale of marijuana in contravention of the CSA; (iv) preparing or issuing regulations governing the manufacture, distribution, sale, or possession of marijuana in contravention of the CSA; (v) monitoring compliance with state or local laws or regulations that permit the manufacture, distribution, sale, or use marijuana in contravention of the CSA; or (vi) the purchase of evidence and the purchase of information. The result of expended funds (e.g. equipment, supplies and other resources) must be directly related to and must only be used for marijuana eradication

activities. While using the Federal funds provided to **THE AGENCY** under this Agreement for activities on Federal land, **THE AGENCY** agrees to notify the appropriate local office of the U.S. Department of Agriculture, (Forest Service) and the U.S. Department of the Interior (Bureau of Land Management, National Park Service, Fish and Wildlife Service, Bureau of Indian Affairs, and/or Bureau of Reclamation) of **THE AGENCY's** presence on Federal land.

4. The Federal funds provided to **THE AGENCY** are primarily intended for payment of deputies'/officers' overtime while those deputies and officers are directly engaged in the illicit cannabis eradication process, **(per DOJ policy, the annual maximum overtime reimbursement rate is based on the current year General Pay Scale / rest of the United States and cannot exceed 25% of a GS-12, Step 1; the funds shall only be used to pay the normal overtime rate, i.e., time and a half. The overtime reimbursement rate "shall not include any cost for benefits, such as retirement, FICA, or other expenses", which is specifically prohibited by DOJ)** and for per diem and other direct costs related to the actual conduct of illicit cannabis eradication. Examples of such costs includes rental of aircraft, fuel for aircraft, and minor repairs and maintenance necessitated by use to support illicit cannabis eradication. These Federal funds are not intended as a primary source of funding for the purchase of equipment, supplies, or other resources. When Domestic Cannabis Eradication Suppression Program (DCE/SP) funds are used to purchase supplies, equipment, or other resources, those items must be directly related to and must only be used for marijuana eradication activities and may not be used to perform any of the following functions: (i) issuing licenses, permits, or other forms of authorization permitting the holder to manufacture, distribute, sell, or use marijuana in contravention of the CSA; (ii) conducting ancillary activities related to the issuance of such licenses and permits, such as background checks on applicants; (iii) collecting state or local tax or licensing revenue related to the manufacture, distribution, or sale of marijuana in contravention of the CSA; (iv) preparing or issuing regulations governing the manufacture, distribution, sale, or possession of marijuana in contravention of the CSA; or (v) monitoring compliance with state or local laws or regulations that permit the manufacture, distribution, sale, or use marijuana in contravention of the CSA. *[Agency Initials]*

All purchases of equipment, supplies and other resources must be requested in writing, **through** the respective DEA Division, **to the Investigative Support Section (ODS)**. Requests must include manufacturer specifications and pricing of the item (including tax, if applicable) to be purchased. The DEA Division personnel will notify the state/local agency whether or not the purchase has been approved. *[Agency Initials]* Expenditures for equipment, supplies, and other resources should not exceed 10% of the total Federal funds awarded. Although equipment, supplies, and other resources may be specifically itemized in the Operation Plan, they **are not automatically approved for purchase.** *[Agency Initials]* All requests for purchases must be received in HQ/ODS by July 15th. Exemptions to any of these requirements must have prior HQ/ODS approval.

Per the DOJ, none of the funds allocated to you may be used to purchase promotional items, gifts, mementos, tokens of appreciation, or other similar items. Prohibited purchases include items justified as training aids if they are embossed, engraved or printed with **THE AGENCY** or program logos. Additionally, the use of DCE/SP funds for Demand Reduction expenses is no longer authorized.

5. In compliance with Section 623 of Public Law 102-141, **THE AGENCY** agrees that no amount of these funds shall be used to finance the acquisition of goods or services unless **THE AGENCY**:
- (a) Specifies in any announcement of the awarding of the contract for the procurement of the goods and services involved the amount of Federal funds that will be used to finance the acquisition; and
  - (b) Expresses the amount announced pursuant to paragraph (a) as a percentage of the total cost of the planned acquisition.

The above requirements only apply to procurements for goods or services that have an aggregate value of \$500,000 or more. Any goods or services acquired under this provision of the agreement must be directly related to and must only be used for marijuana eradication activities and may not be used to perform any of the following functions: (i) issuing licenses, permits, or other forms of authorization permitting the holder to manufacture, distribute, sell, or use marijuana in contravention of the CSA; (ii) conducting ancillary activities related to the issuance of such licenses and permits, such as background checks on applicants; (iii) collecting state or local tax or licensing revenue related to the manufacture, distribution, or sale of marijuana in contravention of the CSA; (iv) preparing or issuing regulations governing the manufacture, distribution, sale, or possession of marijuana in contravention of the CSA; or (v) monitoring compliance with state or local laws or regulations that permit the manufacture, distribution, sale, or use marijuana in contravention of the CSA.

6. If DEA approves the purchase of “supplies” as defined in 2 C.F.R. § 200.314 (all tangible personal property other than “equipment” as defined by 2 C.F.R. § 200.313), and there is a residual inventory of unused supplies exceeding \$5,000 in total aggregate fair market value upon termination or completion of this Agreement, and if the supplies are not needed for any other federally sponsored programs or projects, **THE AGENCY** shall compensate DEA for DEA’s share and in any case the supplies will not be used directly or indirectly to support any state, county or local entity that authorizes cultivating marijuana or has direct oversight or regulatory responsibilities for a state authorized marijuana program. **THE AGENCY** agrees that any unused supplies not exceeding \$5,000 in total aggregate fair market value upon termination or completion of this Agreement will either be used for the marijuana eradication activities, returned to DEA, or destroyed, but in any case will not be used to perform any of the following functions: (i) issuing licenses, permits, or other forms of authorization permitting the holder to manufacture, distribute, sell, or use marijuana in contravention of the CSA; (ii) conducting ancillary activities related to the issuance of such licenses and permits, such as background checks on applicants; (iii) collecting state or local tax or licensing revenue related to the manufacture, distribution, or sale of marijuana in contravention of the CSA; (iv) preparing or issuing regulations governing the manufacture, distribution, sale, or possession of marijuana in contravention of the CSA; or (v) monitoring compliance with state or local laws or regulations that permit the manufacture, distribution, sale, or use marijuana in contravention of the CSA.
7. If DEA approves the purchase of equipment as defined at 2 C.F.R. § 200.313 (tangible, non-expendable personal property having a useful life of more than one year and an

acquisition cost of \$5,000 or more per unit) for the use of **THE AGENCY**'s personnel engaged in illicit cannabis eradication under this Agreement, **THE AGENCY** will use, manage, and dispose of the equipment in accordance with 2 C.F.R. § 200.313, except that in no case, regardless of useful life and acquisition cost, will the equipment be used directly or indirectly to perform any of the following functions: (i) issuing licenses, permits, or other forms of authorization permitting the holder to manufacture, distribute, sell, or use marijuana in contravention of the CSA; (ii) conducting ancillary activities related to the issuance of such licenses and permits, such as background checks on applicants; (iii) collecting state or local tax or licensing revenue related to the manufacture, distribution, or sale of marijuana in contravention of the CSA; (iv) preparing or issuing regulations governing the manufacture, distribution, sale, or possession of marijuana in contravention of the CSA; or (v) monitoring compliance with state or local laws or regulations that permit the manufacture, distribution, sale, or use marijuana in contravention of the CSA.

8. Payments by DEA to **THE AGENCY** will be in accordance with a schedule determined by DEA. No funds will be paid by DEA to **THE AGENCY** under this Agreement until DEA has received to its satisfaction an accounting of the expenditures of all funds paid to **THE AGENCY** during the previous year Agreement. The final/closeout expenditure will be documented on the September (FINAL) DCESP Monthly Accounting Form.
9. It is understood and agreed by **THE AGENCY** that, in return for DEA's payment to **THE AGENCY** for Federal funds, **THE AGENCY** will comply with all applicable Federal statutes, regulations, guidance, and orders, including previous OMB guidance under OMB **Circular A-102** (Grants and Cooperative Agreements With State and Local Governments), OMB **Circular A-87** (Cost Principles for State, Local and Indian Tribal Governments), and **OMB Circular A-133** (Audits of States, Local Governments and Non-Profit Organizations), which have been combined in 2 C.F.R. Part 200, effective December 26, 2014. In addition, 2 C.F.R. Part 2867 (Non- Procurement Debarment and Suspension), 28 C.F.R. Part 83 (Drug-Free Workplace Act common rule), and 28 C.F.R. Part 69 (Byrd Anti-Lobbying Amendment common rule) apply. (Note: The LOA is reimbursable agreement, not a grant; therefore, for purposes of the DCE/SP, DEA requires an audit completed regardless of the threshold amount listed in 2 C.F.R. Part 200. The DCE/SP does not have an assigned Catalog of Federal of Domestic Assistance (CFDA) number. Audits can be conducted without a CFDA number. The auditor must send an email to the Federal Audit Clearinghouse [erd.fac@census.gov](mailto:erd.fac@census.gov) with their agency's name and EIN number and the information will be forwarded to them. In conjunction with the beginning date of the award, the audit report period of **THE AGENCY** under the single audit requirement is **FY-21** (10/01/2020 through 09/30/2021).
10. **THE AGENCY** acknowledges that arrangements have been made for any required financial and compliance audits and audits will be made within the prescribed audit reporting cycle. **THE AGENCY** understands that failure to furnish an acceptable audit as determined by the cognizant Federal agency may be a basis for denial of future Federal funds and/or refunding of Federal funds and may be a basis for limiting **THE AGENCY** to payment by reimbursement on a cash basis. **THE AGENCY** further understands that its use of DEA funds or the result of expended DEA funds (e.g. equipment, supplies and other resources) for any use other than the marijuana eradication program activities, including but not limited to its use directly or indirectly to perform any of the following functions: (i) issuing

licenses, permits, or other forms of authorization permitting the holder to manufacture, distribute, sell, or use marijuana in contravention of the CSA; (ii) conducting ancillary activities related to the issuance of such licenses and permits, such as background checks on applicants; (iii) collecting state or local tax or licensing revenue related to the manufacture, distribution, or sale of marijuana in contravention of the CSA; (iv) preparing or issuing regulations governing the manufacture, distribution, sale, or possession of marijuana in contravention of the CSA; or (v) monitoring compliance with state or local laws or regulations that permit the manufacture, distribution, sale, or use marijuana in contravention of the CSA, will be a basis for denial of future Federal funds and/or refunding of Federal funds and may be a basis for limiting **THE AGENCY** to payment by reimbursement on a cash basis.

11. **THE AGENCY** shall maintain complete and accurate reports, records, and accounts of all obligations and expenditures of DEA funds under this Agreement in accordance with generally accepted government accounting principles and in accordance with state laws and procedures for expending and accounting for its own funds. **THE AGENCY** shall further maintain its records of all obligations and expenditures of DEA funds under this Agreement in accordance with all instructions provided by DEA to facilitate on-site inspection and auditing of such records and accounts.
12. **THE AGENCY** shall permit and have available for examination and auditing by DEA, the U.S. Department of Justice Office of Inspector General, the Government Accountability Office, and any of their duly authorized agents and representatives, any and all investigative reports, records, documents, accounts, invoices, receipts, and expenditures relating to this Agreement. In addition, **THE AGENCY** will maintain all such foregoing reports and records for six years after termination of this Agreement or until after all audits and examinations are completed and resolved, whichever is longer.
13. **THE AGENCY** agrees that an authorized officer or employee will execute and return to the DEA Regional Contractor, the LOA; 1) Electronic Funds Transfer Memorandum; 2) Certifications Regarding Lobbying; Debarment, Suspension, & Other Responsibility Matters; Drug Free Workplace Requirements (OJP Form 406 1/6); and the 3) Assurances (OJP Form 4000/3). **THE AGENCY** acknowledges that this Agreement will not take effect and that no Federal funds will be awarded by DEA until DEA receives the completed LOA package.
14. Employees of **THE AGENCY** shall at no time be considered employees of the U.S. Government or DEA for any purpose, nor will this Agreement establish an agency relationship between **THE AGENCY** and DEA.
15. **THE AGENCY** shall be responsible for the acts or omissions of **THE AGENCY's** personnel. **THE AGENCY** and **THE AGENCY's** employees shall not be considered as the agent of any other participating entity. Nothing herein is intended to waive or limit sovereign immunity under other federal or state statutory or constitutional authority. This Agreement creates no liability on the part of the DEA, its agents or employees, or the U.S. Government for any claims, demands, suits, liabilities, or causes of action of whatever kind and designation, and wherever located in the **State of Wyoming** resulting from the DCE/SP funded by DEA.

16. **THE AGENCY** shall comply with Title VI of the Civil Rights Act of 1964, Section 504 of the Rehabilitation Act of 1973, the Age Discrimination Act of 1975, as amended, and all requirements imposed by or pursuant to the regulations of the U.S. Department of Justice implementing those laws, 28 C.F.R. Part 42, Subparts C, F, G, H, and I.
17. Upon termination of the Agreement, **THE AGENCY** will prepare a September (FINAL) Accounting Form and a general ledger itemizing the breakdown of final expenditures and if applicable, attach invoices reflecting the expenditures for equipment in excess of \$2,500, which was previously approved by DEA Headquarters, and the expenses associated with rental or leasing of aircraft. Report should be submitted electronically to the DEA Regional Contractor by October 31<sup>st</sup>.
18. The duration of this Agreement shall be as specified in Paragraph 3, except that this Agreement may be terminated by either party after 30 day written notice to the other party. All obligations that are outstanding on the above prescribed termination date or on the date of any thirty (30) day notice of termination shall be liquidated by **THE AGENCY** within sixty (60) days thereof, in which event DEA will only be liable for obligations incurred by **THE AGENCY** during the terms of this Agreement. In no event shall **THE AGENCY** incur any new obligations during the period of notice of termination. In the event that the agreement is terminated, any DEA funds that have been obligated or expended and the result of expended funds (e.g. equipment, supplies and other resources) will be used and disposed of in accordance with the provisions of this agreement.
19. **THE AGENCY** must be registered in the System for Award Management (SAM) to receive payment of Federal funds. There are two steps to registering in SAM. **First, THE AGENCY** must have a Data Universal Numbering System (DUNS) number. [A "+4 extension" to a DUNS number (DUNS+4) is required when there is a need for more than one bank/electronic funds transfer account for a location.] A DUNS number may be obtained via the internet (<http://fedgov.dnb.com/webform>) or by phone (U.S. and U.S. Virgin Islands: 1-866-705-5711; Alaska and Puerto Rico: 1-800-234-3867). **Second, THE AGENCY** must then register with SAM via the internet SAM [www.sam.gov](http://www.sam.gov). Questions regarding the internet registration process may be directed to 1-866-606-8220 (follow the prompts for SAM). Both the DUNS number and registration in SAM are free of charge.

**Note: It is THE AGENCY's responsibility to update their SAM registration annually or whenever a change occurs.**

**THE AGENCY's** current DUNS No. is 15272014

**THE AGENCY's** opportunity to enter into this Agreement with DEA and to receive the Federal funds expires ninety days from date of issuance. Agreement issued December 2020.

**CASPER POLICE DEPARTMENT**

Printed Name & Signature: KEITH ALPHRETERS  (Blue Ink Only)

Title: CHIEF OF POLICE Date: 12-28-2020

*Agency, please submit original signed LOA & associated paperwork to your DEA Regional Contractor.*

**DRUG ENFORCEMENT ADMINISTRATION**

Printed Name & Signature: \_\_\_\_\_ (Blue Ink Only)

Special Agent in Charge – Denver Field Division Date: \_\_\_\_\_

*SAC, please submit original signed LOA & associated paperwork to your Fiscal Office.*

**DEA DIVISIONAL FISCAL CLERK MUST INPUT INTO UFMS & COMPLETE THE BOTTOM OF THIS SECTION**

ACCOUNTING CLASSIFICATION/OBLIGATION NUMBER:

2021/AFF-B-OP/OD/6025000/DEA-JLE/DCE: \_\_\_\_\_

UFMS Input Date: \_\_\_\_\_ DNC No. \_\_\_\_\_

DNO No. \_\_\_\_\_ DDP No. \_\_\_\_\_

Printed Name: \_\_\_\_\_ Signature: \_\_\_\_\_

*Fiscal, please submit original signed LOA & associated paperwork to your DEA Regional Contractor.*





**U. S. Department of Justice**  
Drug Enforcement Administration  
Investigative Support Section (ODS)  
DEA Headquarters

*www.dea.gov*

October 1, 2020

All Domestic Cannabis  
Eradication/Suppression Program (DCE/SP)  
Participating Agencies

Funding for the Domestic Cannabis Eradication/Suppression Program (DCE/SP) is only available by electronic transfer. Funds will be transferred directly into the Letter of Agreement (LOA) agency's bank account. In order to process electronic transfers, the following information must be provided:

Agency Name on Bank Account: City of Casper

Account Number: \_\_\_\_\_

Name of Bank/Financial Institution: First Interstate Bank

Address of Bank/Financial Institution: P.O. Box 40 Casper, WY

Telephone Number of Bank/Financial Institution: 307.235.4325

Contact Person of Bank/Financial Institution: Ann Hicks

Bank/Financial Institution ABA Number: \_\_\_\_\_

State-Local Agency Name / LOA Number: \_\_\_\_\_

E-mail Address for Agency's Financial/  
Accounting Section for Transfer Notifications: dthompson@casperwy.gov

J. Carter Napier, City Manager

\_\_\_\_\_  
Authorized Agency Representative (Name & Title)

\_\_\_\_\_  
Signature of Authorized Agency Representative

\_\_\_\_\_  
Date

Investigative Support Section (ODS)  
DEA Headquarters



U.S. Department of Justice  
Office of Justice Programs  
Office of the Comptroller

---

**CERTIFICATIONS REGARDING LOBBYING; DEBARMENT, SUSPENSION AND  
OTHER RESPONSIBILITY MATTERS; AND DRUG-FREE WORKPLACE REQUIREMENTS**

---

Applicants should refer to the regulations cited below to determine the certification to which they are required to attest. Applicants should also review the instructions for certification included in the regulations before completing this form. Signature of this form provides for compliance with certification requirements under 28 CFR Part 69, "New Restrictions on Lobbying" and 28 CFR Part 67, "Government-wide Debarment and Suspension (Nonprocurement) and Government-wide Requirements for Drug-Free Workplace (Grants)." The certifications shall be treated as a material representation of fact upon which reliance will be placed when the Department of Justice determines to award the covered transaction, grant, or cooperative agreement.

**I. LOBBYING**

As required by Section 1352, Title 31 of the U.S. Code, and implemented at 28 CFR Part 69, for persons entering into a grant or cooperative agreement over \$100,000, as defined at 28 CFR Part 69, the applicant certifies that:

- (a) No Federal appropriated funds have been paid or will be paid, by or on behalf of the undersigned, to any person for influencing or attempting to influence an officer or employee of any agency, a Member of Congress, an officer or employee of Congress, or an employee of a Member of Congress in connection with the making of any Federal grant, the entering into of any cooperative agreement, and the extension, continuation, renewal, amendment, or modification of any Federal grant or cooperative agreement;
- (b) If any funds other than Federal appropriated funds have been paid or will be paid to any person for influencing or attempting to influence an officer or employee of any agency, a Member of Congress, an officer or employee of Congress, or an employee of a Member of Congress in connection with this Federal grant or cooperative agreement, the undersigned shall complete and submit Standard Form - LLL, "Disclosure of Lobbying Activities," in accordance with its instructions;
- (c) The undersigned shall require that the language of this certification be included in the award documents for all subawards at all tiers (including subgrants, contracts under grants and cooperative agreements, and subcontracts) and that all subrecipients shall certify and disclose accordingly.

**2. DEBARMENT, SUSPENSION, AND OTHER  
RESPONSIBILITY MATTERS  
(DIRECT RECIPIENT)**

As required by Executive Order 12549, Debarment and Suspension, and implemented at 28 CFR Part 67, for prospective participants in primary covered transactions, as defined at 28 CFR Part 67, Section 67.510--

A. The applicant certifies that it and its principals:

- (a) Are not presently debarred, suspended, proposed for debarment, declared ineligible, sentenced to a denial of Federal benefits by a State or Federal court, or voluntarily excluded from covered transactions by any Federal department or agency;
- (b) Have not within a three-year period preceding this application been convicted of or had a civil judgment rendered against them for commission of fraud or a criminal offense in connec-

public (Federal, State, or local) transaction or contract under a public transaction; violation of Federal or State antitrust statutes or commission of embezzlement, theft, forgery, bribery, falsification or destruction of records, making false statements, or receiving stolen property;

- (c) Are not presently indicted for or otherwise criminally or civilly charged by a governmental entity (Federal, State, or local) with commission of any of the offenses enumerated in paragraph (1)(b) of this certification; and
- (d) Have not within a three-year period preceding this application had one or more public transactions (Federal, State, or local) terminated for cause or default; and

B. Where the applicant is unable to certify to any of the statements in this certification, he or she shall attach an explanation to this application.

**3. DRUG-FREE WORKPLACE  
(GRANTEES OTHER THAN INDIVIDUALS)**

As required by the Drug-Free Workplace Act of 1988, and implemented at 28 CFR Part 67, Subpart F, for grantees, as defined at 28 CFR Part 67 Sections 67.615 and 67.620--

A. The applicant certifies that it will or will continue to provide a drug-free workplace by:

(a) Publishing a statement notifying employees that the unlawful manufacture, distribution, dispensing, possession, or use of a controlled substance is prohibited in the grantee's workplace and specifying the actions that will be taken against employees for violation of such prohibition;

(b) Establishing an on-going drug-free awareness program to inform employees about--

- (1) The dangers of drug abuse in the workplace;
  - (2) The grantee's policy of maintaining a drug-free workplace;
  - (3) Any available drug counseling, rehabilitation, and employee assistance programs; and
  - (4) The penalties that may be imposed upon employees for drug abuse violations occurring in the workplace;
- (c) Making it a requirement that each employee to be engaged in the performance of the grant be given a copy of the statement required by paragraph (a);
- (d) Notifying the employee in the statement required by paragraph (a) that, as a condition of employment under the grant,

- (1) Abide by the terms of the statement; and
- (2) Notify the employer in writing of his or her conviction for a violation of a criminal drug statute occurring in the workplace no later than five calendar days after such conviction;
- (e) Notifying the agency, in writing, within 10 calendar days after receiving notice under subparagraph (d)(2) from an employee or otherwise receiving actual notice of such conviction. Employers of convicted employees must provide notice, including position title, to: Department of Justice, Office of Justice Programs, ATTN: Control Desk, 810 7<sup>th</sup> Street, N.W., Washington, D.C. 20531. Notice shall include the identification number(s) of each affected grant;
- (f) Taking one of the following actions, within 30 calendar days of receiving notice under subparagraph (d)(2), with respect to any employee who is so convicted--

- (1) Taking appropriate personnel action against such an employee, up to and including termination, consistent with the requirements of the Rehabilitation Act of 1973, as amended; or
- (2) Requiring such employee to participate satisfactorily in a drug abuse assistance or rehabilitation program approved for such purposes by a Federal, State, or local health, law enforcement, or other appropriate agency;
- (g) Making a good faith effort to continue to maintain a drug-free workplace through implementation of paragraphs (a), (b), (c), (d), (e), and (f).

B. The grantee may insert in the space provided below the site(s) for the performance of work done in connection with the specific grant:  
 Place of Performance (Street address, city, county, state, zip code)

Check \_\_\_ if there are workplaces on file that are not identified here.

Section 67. 630 of the regulations provides that a grantee that is a State may elect to make one certification in each Federal fiscal year. A copy of which should be included with each application for Department of Justice funding. States and State agencies may elect to use OJP Form 4061/7.

Check \_\_\_ if the State has elected to complete OJP Form 4061/7.

**DRUG-FREE WORKPLACE  
 (GRANTEES WHO ARE INDIVIDUALS)**

As required by the Drug-Free Workplace Act of 1988, and implemented at 28 CFR Part 67, Subpart F, for grantees, as defined at 28 CFR Part 67; Sections 67.615 and 67.620--

A. As a condition of the grant, I certify that I will not engage in the unlawful manufacture, distribution, dispensing, possession, or use of a controlled substance in conducting any activity with the grant; and

B. If convicted of a criminal drug offense resulting from a violation occurring during the conduct of any grant activity, I will report the conviction, in writing, within 10 calendar days of the conviction, to: Department of Justice, Office of Justice

As the duly authorized representative of the applicant, I hereby certify that the applicant will comply with the above certifications.

**1. Grantee Name and Address:**

City of Casper Police Department  
 201 N. David Street  
 Casper, WY B2601

2021-114

**2. Application Number and/or Project Name**

2021-114  
 Cannabis Interdiction Grant Casper Police Department

**3. Grantee IRS/Vendor Number**

**4. Typed Name and Title of Authorized Representative**

J. Carter Napier, City Manager

**5. Signature**

**6. Date**

(BLUE INK ONLY)



## ASSURANCES

The Applicant hereby assures and certifies compliance with all Federal statutes, regulations, policies, guidelines and requirements, including OMB Circulars No. A-21, A-87, A-110, A-122, A-133; E.O. 12372 and Uniform Administrative Requirements for Grants and Cooperative Agreements - 28 CFR, Part 66, Common rule, that govern the application, acceptance and use of Federal funds for this federally-assisted project. Also the Applicant assures and certifies that:

1. It possesses legal authority to apply for the grant; that a resolution, motion or similar action has been duly adopted or passed as an official act of the applicant's governing body, authorizing the filing of the application, including all understandings and assurances contained therein, and directing and authorizing the person identified as the official representative of the applicant to act in connection with the application and to provide such additional information may be required.
2. It will comply with requirements of the provisions of the Uniform Relocation Assistance and Real Property Acquisitions Act of 1970 (P.L. 91-646) which provides for fair and equitable treatment of persons displaced as a result of Federal and federally - assisted programs.
3. It will comply with provisions of Federal law which limit certain political activities of employees of a State or local unit of government whose principal employment is in connection with an activity financed in whole or in part by Federal grants. (5 USC 1501, et seq.)
4. It will comply with the minimum wage and maximum hours provisions of the Federal Fair Labor Standards Act if applicable.
5. It will establish safeguards to prohibit employees from using their positions for a purpose that is or gives the appearance of being motivated by a desire for private gain for themselves or others, particularly those with whom they have family, business, or other ties.
6. It will give the sponsoring agency or the Comptroller General, through any authorized representative, access to and the right to examine all records, books, papers, or documents related to the grant.
7. It will comply with all requirements imposed by the Federal sponsoring agency concerning special requirements of law, program requirements, and other administrative requirements.
8. It will insure that the facilities under its ownership, lease or supervision which shall be utilized in the accomplishment of the project are not listed on the Environmental Protection Agency's (EPA) list of Violating Facilities and that it will notify the Federal grantor agency of the receipt of any communication from the Director of the EPA Office of Federal Activities indicating that a facility to be used in the project is under consideration for listing by the EPA.
9. It will comply with the flood insurance purchase requirements of Section 102(a) of the Flood Disaster Protection Act of 1973, Public Law 93-234, 87 Stat. 975, 14 approved December 31, 1976, Section 102(a) requires, on and after March 2, 1975, the purchase of flood insurance in communities where such insurance is available as a condition for the receipt of any Federal financial assistance for construction or acquisition purposes for use in any area that has been identified by the Secretary of the Department of Housing and Urban Development as an area having special flood hazards. The phrase "Federal financial assistance" includes any form of loan, grant, guaranty, insurance payment, rebate, subsidy, disaster assistance loan or grant, or any other form of direct or indirect Federal assistance.
10. It will assist the Federal grantor agency in its compliance with Section 106 of the National Historic Preservation Act of 1966 as amended (16 USC 470), Executive Order 11593, and the Archeological and Historical Preservation Act of 1966 (16 USC 569 a-1 et seq.) by (a) consulting with the State Historic Preservation Officer on the conduct of investigations, as necessary, to identify properties listed in or eligible for inclusion in the National Register of Historic Places that are subject to adverse effects (see 36 CFR Part 800.8) by the activity, and notifying the Federal grantor agency of the existence of any such properties, and by (b) complying with all requirements established by the Federal grantor agency to avoid or mitigate adverse effects upon such properties.
11. It will comply, and assure the compliance of all its subgrantees and contractors, with the applicable provisions of Title I of the Omnibus Crime Control and Safe Streets Act of 1968, as amended, the Juvenile Justice and Delinquency Prevention Act, or the Victims of Crime Act, as appropriate; the provisions of the current edition of the Office of Justice Programs Financial and Administrative Guide for Grants, M7100.1; and all other applicable Federal laws, orders, circulars, or regulations.
12. It will comply with the provisions of 28 CFR applicable to grants and cooperative agreements including Part 18, Administrative Review Procedure; Part 20, Criminal Justice Information Systems, Part 22, Confidentiality of Identifiable Research and Statistical Information; Part 23, Criminal Intelligence Systems Operating Policies; Part 30, Intergovernmental Review of Department of Justice Programs and Activities; Part 42, Nondiscrimination/Equal Employment Opportunity Policies and Procedures; Part 61, Procedures for Implementing the National Environmental Policy Act; Part 63, Floodplain Management and Wetland Protection Procedures; and Federal laws or regulations applicable to Federal Assistance Programs.
13. It will comply, and all its contractors will comply, with the nondiscrimination requirements of the Omnibus Crime Control and Safe Streets Act of 1968, as amended, 42 USC 3789(d), or Victims of Crime Act (as appropriate); Title VI of the Civil Rights Act of 1964, as amended; Section 504 of the Rehabilitation Act of 1973, as amended; Subtitle A, Title II of the Americans with Disabilities Act (ADA) (1990); Title IX of the Education Amendments of 1972; the Age Discrimination Act of 1975; Department of Justice Non-Discrimination Regulations, 28 CFR Part 42, Subparts C, D, E, and G; and Department of Justice regulations on disability discrimination, 28 CFR Part 35 and Part 39.
14. In the event a Federal or State court or Federal or State administrative agency makes a finding of discrimination after a due process hearing on the grounds of race, color, religion, national origin, sex, or disability against a recipient of funds, the recipient will forward a copy of the finding to the Office for Civil Rights, Office of Justice Programs.
15. It will provide an Equal Employment Opportunity Program if required to maintain one, where the application is for \$500,000 or more.
16. It will comply with the provisions of the Coastal Barrier Resources Act (P.L. 97-348) dated October 19, 1982 (16 USC 3501 et seq.) which prohibits the expenditure of most new Federal funds within the units of the Coastal Barrier Resources System.

Signature

Date

Agency Name & LOA Number:

12-28-2010

RESOLUTION NO.21-10

A RESOLUTION AUTHORIZING ACCEPTANCE OF FUNDS AWARDED FROM THE DRUG ENFORCEMENT ADMINISTRATION TO BE USED FOR OVERTIME REIMBURSEMENT.

WHEREAS, the City of Casper has been awarded funds in the amount of Thirty-Five Thousand Dollars (\$35,000) to be used for overtime reimbursement of officers that are directly involved in the eradication and suppression of illicit cannabis.

WHEREAS, the City of Casper desires to accept the funds from the Drug Enforcement Agency; and,

NOW, THEREFORE, BE IT RESOLVED BY THE GOVERNING BODY OF THE CITY OF CASPER, WY: That the funds from the Drug Enforcement Agency by hereby accepted.

BE IT FURTHER RESOLVED: That the City Manager and/or his/her designee is hereby authorized to execute all documents pertaining to said award of monies.

PASSED, APPROVED AND ADOPTED this \_\_\_\_ day of \_\_\_\_\_, 2021.

APPROVED AS TO FORM:

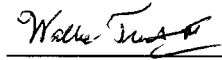
  
\_\_\_\_\_

ATTEST:

CITY OF CASPER, WYOMING  
A Municipal Corporation

\_\_\_\_\_  
Fleur Tremel  
City Clerk

\_\_\_\_\_  
J. Carter Napier  
City Manager

January 14, 2021

MEMO TO: J. Carter Napier, City Manager *JCN*

FROM: Andrew Beamer, P.E., Public Services Director *AB*  
Ethan Yonker, P.E., Associate Engineer

SUBJECT: Authorizing an Agreement with Caspar Building Systems, Inc., in the Amount of \$86,626.00, for the Baler Building Locker Room Remodel, Project No. 20-021

**Meeting Type & Date**

Regular Council Meeting  
February 2, 2021

**Action Type**

Resolution

**Recommendation**

That Council, by resolution, authorize an Agreement with Caspar Building Systems, Inc., in the Amount of \$86,626.00, for the Baler Building Locker Room Remodel, Project No. 20-021. Furthermore, it is recommended that Council authorize a construction contingency account in the amount of \$13,374.00, for a total project amount of \$100,000.00

**Summary**

This project is for improvements to locker rooms in the Baler Building. The improvements will create a larger breakroom for Balefill employees, new lockers in the men's and women's locker rooms, and new flooring in the breakroom and locker rooms.

The bids received for this work are as follows:

<u>CONTRACTOR</u>	<u>BUISNESS LOCATION</u>	<u>BID AMOUNT</u>
<b>Caspar Building Systems</b>	<b>Casper, Wyoming</b>	<b>\$86,626.00</b>
Pope Construction	Mills, Wyoming	\$97,899.00
Transmission Distribution Services	Glenrock, Wyoming	\$109,777.62
Valor Construction	Casper, Wyoming	\$130,086.50
Haass Construction	Casper, Wyoming	\$131,189.00

By State Statute, all in-state bidders receive a five percent (5%) bid preference. The in-state preference does not impact the outcome of the low bidder, as the low bidder was an in-state bidder.

Work is scheduled to be completed 60 days after Notice to Proceed is issued, and 30 days after Substantial Completion is issued, a Notice to proceed will be issued no later than July 2, 2021. The estimate prepared by Hein|Bond Architects was \$120,520.00.

**Financial Considerations**

The budget available for the project is \$153,093.33 with \$24,093.33 coming from Balefill Reserves and \$129,000.00 coming from Balefill Current Revenues.

**Oversight/Project Responsibility**

Ethan Yonker, P.E., Associate Engineer, Public Services

**Attachments**

Resolution

Agreement



STANDARD FORM OF  
AGREEMENT BETWEEN OWNER AND CONTRACTOR  
(Approved by City Attorney, 2004)

THIS AGREEMENT is made between the City of Casper, Wyoming, 200 North David Street, Casper, Wyoming 82601, hereinafter referred to as the "Owner," and Caspar Building Systems, Inc. 1975 Old Salt Creek Highway, Casper, Wyoming, 82601, hereinafter referred to as the "Contractor."

WHEREAS, the City of Casper desires to enter into a contract an interior remodel of the locker room located on the second floor of the Baler Building at the City of Casper Solid Waste Facility; and,

WHEREAS, Caspar Building Systems, Inc., is able and willing to provide those services specified as the BALER BUILDING LOCKER ROOM REMODEL, Project 19-071.

NOW, THEREFORE, it is hereby agreed as follows:

ARTICLE 1. WORK.

Contractor shall perform all the work required by the Contract Documents for the BALER BUILDING LOCKER ROOM REMODEL, Project 19-071.

ARTICLE 2. ENGINEER.

The Project has been designed by the Hein|Bond Architects in who is hereinafter referred to as the "Engineer" and who is to act as Owner's representative, assume all duties and responsibilities and have the rights and authority assigned to Engineer in the Contract Documents in connection with completion of the Work in accordance with the Contract Documents.

ARTICLE 3. CONTRACT TIME.

Work will be considered substantially complete when the work shown in the drawings and specifications is complete and the locker rooms can be utilized by City staff for their intended use.

- 3.1 The Work will be substantially completed within 60 calendar days of an executed Notice to Proceed, and completed and ready for final payment in accordance with Article 14 of the General Conditions within 90 calendar days. Notice to Proceed will be issued no later than July 1, 2021.
- 3.2 Liquidated Damages. Owner and Contractor recognize that time is of the essence of this Agreement and that Owner will suffer financial loss if the Work is not substantially completed by the time specified in Paragraph 3.1 above, plus any extension thereof allowed in accordance with Article 12 of the General Conditions. They also recognize the delays, expense, and difficulties involved in proving in a legal or arbitration proceeding the actual

loss suffered by Owner if the Work is not substantially completed on time. Accordingly, instead of requiring any such proof, Owner and Contractor agree that as liquidated damages for delay (but not as a penalty) Contractor shall pay Owner Seven Hundred Fifty Dollars (\$750.00) for each day that expires after the time specified in Paragraph 3.1 for substantial completion. After Substantial Completion, if Contractor shall neglect, refuse, or fail to complete the remaining work within the time specified in paragraph 3.1 for completion and readiness for final payment or any proper extension thereof granted by Owner, Contractor shall pay Owner Two Hundred Fifty Dollars (\$250.00) for each day that expires after the time specified in paragraph 3.1 for completion and readiness for final payment. It is further agreed that such liquidated damages are not a penalty, but represent the parties' best estimate of actual damages.

#### ARTICLE 4. CONTRACT PRICE.

In Consideration of the performance of the work in accordance with the Contract documents for this Unit Price Contract, Owner shall pay Contractor in current funds a not-to-exceed total contract price of Eighty-Six Thousand Six Hundred Twenty-Six and 00/100 Dollars (\$86,626.00), subject to additions and deductions by Change Order approved by the Owner. The contract fee shall be based on materials actually furnished and installed and services actually provided based on the unit prices contained in the Bid Form and Itemized Bid Schedule, included as Exhibit "A" (pages BF-1 through BF-4, Bid Form and Bid Schedule) and by this reference made a part of this Agreement.

#### ARTICLE 5. PAYMENT PROCEDURES.

Contractor shall submit Applications for Payment in accordance with Article 14 of the General Conditions. Applications for Payment will be processed through the Engineer as provided in the General Conditions.

5.1 Progress Payments. Owner shall make progress payments on the basis of Contractor's Applications for Payment as recommended by Engineer, on or about the 25th day of each month during construction as provided below. All progress payments will be on the basis of the progress of the Work measured by the Schedule of Values provided for in Paragraph 14.1 of the General Conditions, subject to the cutoff and submittal dates provided in the General Provisions.

5.1.1 Payments will be made in an amount equal to ninety-five percent (95%) of the Work completed, and ninety-five percent (95%) of Invoice Cost of materials and equipment not incorporated in the work but delivered and suitably stored, less in each case the aggregate of payments previously made.

5.1.3 In the event the Contractor makes only one application for payment upon completion of the entire project, the Owner shall withhold five percent (5%) of the Total Contract Price as retainage, said retainage to be paid in accordance with the provisions of Paragraph 5.3, Final Payment.

- 5.1.4 Should amounts owed by the Contractor to the City for any goods, services, licenses, permits or any other item or purpose remain unpaid beyond the City's general credit policy, those amounts may be deducted from the payment being made by the City to the Contractor pursuant to this agreement.
- 5.2 OWNER may withhold progress payments if CONTRACTOR fails to submit an updated progress schedule with the application for payment.
- 5.3 Final Payment. Upon final completion and acceptance of the Work in accordance with Paragraph 14.13 of the General Conditions, Engineer shall recommend payment and present Contractor's Final Application for Payment to the City. Pursuant to Wyoming State Statutes, final payment cannot be made until forty-one (41) days after publication of the first Notice of Completion.

#### ARTICLE 6. WITHHELD FUNDS.

Pursuant to Wyoming Statutes Section 16-6-701 et seq., withheld percentages for Contracts exceeding \$25,000.00 will be retained in an account in the name of the Contractor (except when specifically waived in writing by Contractor) which has been assigned to the Owner until the Contract is completely, satisfactorily, and finally accepted by the Owner. Unless a depository is designated by the Contractor in a written attachment hereto, the Contractor's signature hereon shall act as authority for the Owner to designate a retainage depository on behalf of the Contractor, for the purposes specified in Wyoming Statutes Section 16-6-704. The Contractor's signature hereon shall act as an assignment of the depository account to the Owner, as provided by Wyoming Statutes Section 16-6-701 et seq., whether the depository is designated by the Contractor or by the Owner.

#### ARTICLE 7. CONTRACTOR'S REPRESENTATIONS.

In order to induce Owner to enter into this Agreement, Contractor makes the following representations:

- 7.1 Contractor has familiarized himself with the nature and extent of the Contract Documents, Work, locality, and with all local conditions and federal, state, and local Laws and Regulations that in any manner may affect cost, progress, or performance of the Work.
- 7.2 Contractor has studied carefully all reports of investigations and test of subsurface and latent physical conditions at the site or otherwise affecting cost, progress, or performance of the work which were relied upon by Engineer in the preparation of the Drawings and Specifications and which have been identified in the Supplementary Conditions.
- 7.3 Contractor has made or caused to be made examinations, investigations, and test and studies as he deems necessary for the performance of the Work at the Contract Price, within the Contract Time, and in accordance with the other terms and conditions of the Contract Documents; and no additional examinations, investigations, tests, reports, or similar data are or will be required by Contractor for such purposes.

- 7.4 Contractor has correlated the results of all such observations, examinations, investigations, tests, reports, and data with the terms and conditions of the Contract Documents.
- 7.5 Contractor has given Engineer written notice of all conflicts, errors, or discrepancies that he has discovered in the Contract Documents and the written resolution thereof by Engineer is acceptable to Contractor.
- 7.6 Contractor certifies that materials containing asbestos will not be used for this project without prior written approval by the Owner.

#### ARTICLE 8. CONTRACT DOCUMENTS.

The Contract Documents which comprise the entire agreement between Owner and Contractor are attached to this Agreement, made a part hereof and consist of the following:

- 8.1 This Agreement (Pages SFA-1 to SFA-5, inclusive).
- 8.2 Exhibit "A" - (pages BF-1 through BF-4, Bid Form and Bid Schedule).
- 8.3 Joint Account Agreement or Letter of Forfeiture waiving same.
- 8.4 Addenda No.   1  .
- 8.5 Performance and Payment Bonds.
- 8.6 Certificates of Insurance, of Workers' Compensation Coverage, and of Unemployment Insurance Coverage.
- 8.7 Notice of Award.
- 8.8 Notice to Proceed.
- 8.9 Minutes of the Pre-Bid Conference, if any.
- 8.10 General Conditions (Pages 00700-1 to 00700-42, inclusive).
- 8.11 Supplementary Conditions (Pages SSC-1 to SSC-15, inclusive).
- 8.12 Technical Specifications, consisting of ten (10) sections.
- 8.13 Shop Drawings and other Submittals furnished by Contractor during performance of the Work and accepted by the Owner.

8.14 Any modifications, amendments, and supplements, including Change Orders, issued pursuant to Paragraphs 3.4 and 3.5 of the General Conditions, on or after the effective date of this Agreement.

8.15 Notice of Substantial Completion.

ARTICLE 9. GOVERNMENTAL CLAIMS ACT

The Owner does not waive any right or rights it may have pursuant to the Wyoming Governmental Claims Act, Wyoming Statutes Section 1-39-101 et seq. The Owner specifically reserves the right to assert any and all immunities, rights, and defenses it may have pursuant to the Wyoming Governmental Claims Act.

ARTICLE 10. MISCELLANEOUS PROVISIONS.

Terms used in this Agreement, which are defined in the General Conditions, shall have the meanings designated in those conditions.

IN WITNESS WHEREOF, the parties hereto have caused this Agreement to be executed in one (1) original copy on the day and year first above written.

DATED this \_\_\_\_\_ day of \_\_\_\_\_, 2021.

(BALER BUILDING LOCKER ROOM REMODEL)  
APPROVED AS TO FORM:

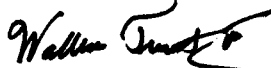

\_\_\_\_\_  
ATTEST:

CONTRACTOR:  
\_\_\_\_\_

By: \_\_\_\_\_

By: \_\_\_\_\_

Title: \_\_\_\_\_

Title: \_\_\_\_\_

ATTEST:

OWNER:  
CITY OF CASPER, WYOMING  
A Municipal Corporation

By: \_\_\_\_\_  
Fleur Tremel

By: \_\_\_\_\_  
Steven K. Freel

Title: City Clerk

Title: Mayor

**EXHIBIT "A"**  
**STANDARD**  
**BID FORM**  
(Approved by City Attorney, 1995)

**PROJECT IDENTIFICATION:** City of Casper  
BALER BUILDING LOCKER ROOM REMODEL,  
Project 19-071

**THIS BID SUBMITTED TO:** City of Casper  
200 North David Street  
Casper, Wyoming 82601

1. The undersigned Bidder proposes and agrees, if this Bid is accepted, to enter into an Agreement with the City in the form included in the Bidding Documents and to complete all Work as specified or indicated in the Bidding Documents for the Contract Price within 60 calendar days of an executed Notice to Proceed, and completed and ready for final payment not later than 30 days following substantial completion, in accordance with the Bidding Documents. A Notice to Proceed will be executed no later than July 2, 2021.
2. Bidder accepts all of the terms and conditions of the Advertisement for Bids and Instructions to Bidders, including without limitation those dealing with the disposition of Bid Guaranty. This Bid will remain effective for thirty (30) days after the day of Bid opening. Bidder will sign the Agreement and submit the Bonds and other documents required by the Bidding Documents within thirty (30) days after the date of the City's Notice of Award.
3. Notice that preferences will be granted pursuant to Wyoming Statutes Section 16-6-101, et seq., is hereby acknowledged.
4. In submitting this Bid, Bidder represents, as more fully set forth in the Bidding Documents, that:
  - A. Bidder has examined copies of all the Bidding Documents and of the following addenda (receipt of all which is hereby acknowledged):

Addendum No. <u>1</u>	Dated <u>01/07/2021</u>
Addendum No. _____	Dated _____
  - B. Bidder has examined the site and locality where the work is to be performed, the federal, state, and local Laws and Regulations, and the conditions affecting cost, progress, or performance of the work and has made such independent investigations as Bidder deems necessary;

C. This Bid is genuine and not made in the interest of or on behalf of any undisclosed person, firm, corporation, or other business entity. Bidder has not directly or indirectly induced or solicited any other Bidder to submit a false or sham Bid. Bidder has not solicited or induced any person, firm, or a corporation to refrain from bidding. Bidder has not sought by collusion to obtain for itself any advantage over any other Bidder or against the City.

5. Bidder is bidding all schedules, alternates, if any, and will complete the Work for unit price(s) stated on the attached bid schedule based on materials actually furnished and installed and services actually provided. The Bid is summarized below on the basis of estimated quantities:

TOTAL BASE BID, IN NUMERALS: \$ 86,626<sup>00</sup>

TOTAL BASE BID, IN WORDS: EIGHTY SIX THOUSAND SIX HUNDRED TWENTY SIX & 0/100 DOLLARS.

6. Bidder agrees that the work for the City will be as provided above.

7. Bidder accepts the provisions of the Bidding Documents as to liquidated damages in the event of failure to complete the work on time, unless otherwise stated as provided below. Bidder agrees that such liquidated damages are not a penalty and that the amount provided is as close an estimate as possible to actual damages. Any exceptions or objections to this provision are stated in writing and attached hereto by Bidder.

8. The following documents are attached to and made a condition of this Bid:

A. Required Bid Guaranty in the form of a Bid Bond. (Unless otherwise provided by the City.)

B. Itemized Bid Schedule.

C. State of Wyoming Certificate of Residency Status, in conformance with the Instructions to Bidders.

9. Communications concerning this Bid shall be addressed to:

Address of Bidder: CASPAR BUILDING SYSTEMS, INC.  
1975 OLD SALT CREEK HWY  
CASPER, WY 82601

10. The terms used in this Bid are defined in and have the meanings assigned to them in the General Conditions, except as provided in the Supplementary Conditions and Bidding Documents.



Submitted on JANUARY 14, \_\_\_\_\_, 2021.

Bidder is bidding as a RESIDENT \_\_\_\_\_ (Insert Resident or Non-Resident)

IF BIDDER IS:

AN INDIVIDUAL

By: \_\_\_\_\_ (seal)  
(Individual's Name)

doing business as: \_\_\_\_\_

Business Address: \_\_\_\_\_  
\_\_\_\_\_  
\_\_\_\_\_

Phone Number: \_\_\_\_\_

A PARTNERSHIP

By: \_\_\_\_\_ (seal)  
(Firm's Name)  
\_\_\_\_\_  
(General Partner)

Business Address: \_\_\_\_\_  
\_\_\_\_\_  
\_\_\_\_\_

Phone Number: \_\_\_\_\_

A CORPORATION OR LIMITED LIABILITY COMPANY

By: CASPAR BUILDING SYSTEMS, INC. (seal)  
(Corporation's or Limited Liability Company's Name)

WYOMING  
(State of Incorporation or Organization)

By:  (seal)  
WES HAYDEN, PRESIDENT

(Title)

(Seal)

Attest: 

Business Address: 1975 OLD SALT CREEK HWY  
CASPER, WY 82601

Phone Number: (307) 235-5690

A JOINT VENTURE

By: \_\_\_\_\_ (seal)  
(Name)

\_\_\_\_\_  
(Address)

By: \_\_\_\_\_ (seal)  
(Name)

\_\_\_\_\_  
(Address)

(Each joint venturer must sign. The manner of signing for each individual, partnership, and corporation that is a party to the joint venture should be in the manner indicated above.)

## Bid Schedule

Exhibit "A"

Baler Building Locker Room Remodel (#7395661)

Owner: Casper WY, City of

Solicitor: Casper WY, City of

01/14/2021 02:00 PM MST

Casper Building Systems, Inc.					
Line Item	Item Description	UofM	Quantity	Unit Price	Extension
					\$86,626.00
1	Selective Demolition	LS	1	\$6,540.00	\$6,540.00
2	Remodel Construction	LS	1	\$51,074.00	\$51,074.00
3	Lockers	EA	12	\$347.00	\$4,164.00
4	Locker Room Flooring	LS	1	\$24,848.00	\$24,848.00
				<b>Base Bid Total:</b>	<b>\$86,626.00</b>

RESOLUTION NO. 21-11

A RESOLUTION AUTHORIZING AN AGREEMENT WITH CASPAR BUILDING SYSTEMS, INC., FOR THE BALER BUILDING LOCKER ROOM REMODEL, PROJECT NO. 19-071.

WHEREAS, the City of Casper desires to enter into a contract for improvements to Baler Building Locker Room Remodel at 3224 Metro Road, Casper; and,

WHEREAS, Caspar Building Systems, Inc., is able and willing to provide those services specified as the Baler Building Locker Room Remodel, Project No. 19-071; and,

WHEREAS, it would be in the best interest of the City to expedite changes in the project by allowing the City Manager to sign change orders effecting time extensions of no more than thirty (30) days, dollar amount changes no greater than Thirteen Thousand Three Hundred Seventy-Four and 00/100 Dollars (\$13,374.00) and other project administration related change orders that do not substantially alter the scope of the project.

NOW, THEREFORE, BE IT RESOLVED BY THE GOVERNING BODY OF THE CITY OF CASPER, WYOMING: That the Mayor is hereby authorized and directed to execute, and the City Clerk to attest, an agreement with Caspar Building Systems, Inc., for those services, in the amount of Eighty-Six Thousand Six Hundred Twenty-Six and 00/100 Dollars (\$86,626.00).

BE IT FURTHER RESOLVED: That the City Manager is hereby authorized to make verified partial payments and contract extensions throughout the project, retaining those amounts prescribed by the agreement, equal to an amount not to exceed Eighty-Six Thousand Six Hundred Twenty-Six and 00/100 Dollars (\$86,626.00) and Thirteen Thousand Three Hundred Seventy-Four and 00/100 Dollars (\$13,374.00) for a construction contingency account, for a total price of One Hundred Thousand and 00/100 Dollars (\$100,000.00).

BE IT FURTHER RESOLVED: That the City Manager is hereby authorized to sign change orders effecting time extensions of no more than thirty (30) days, changes in the dollar amount of the above described agreement not greater than the sum of Thirteen Thousand Three Hundred Seventy-Four and 00/100 Dollars (\$13,374.00), and other project administration related change orders that do not substantially alter the scope of the project.

PASSED, APPROVED, AND ADOPTED this \_\_\_\_ day of \_\_\_\_\_, 2021.

APPROVED AS TO FORM:



ATTEST:

CITY OF CASPER, WYOMING  
A Municipal Corporation

\_\_\_\_\_  
Fleur Tremel  
City Clerk

\_\_\_\_\_  
Steven K. Freel  
Mayor

January 14, 2021

MEMO TO: J. Carter Napier, City Manager 

FROM: Andrew Beamer, P.E., Public Services Director   
Ethan Yonker, P.E., Associate Engineer

SUBJECT: Authorizing an Agreement with Wayne Coleman Construction, Inc., in the Amount of \$90,307.00, for the Horizon Park, Project No. 20-021

**Meeting Type & Date**

Regular Council Meeting  
February 2, 2021

**Action Type**

Resolution

**Recommendation**

That Council, by resolution, authorize an Agreement with Wayne Coleman Construction, Inc., in the Amount of \$90,307.00, for the Horizon Park, Project No. 20-021. Furthermore, it is recommended that Council authorize a construction contingency account in the amount of \$9,000.00, for a total project amount of \$99,307.00

**Summary**

This project is for improvements to Horizon park including; curbswalk, 10' sidewalk, and fencing.

The bids received for this work are as follows:

<u>CONTRACTOR</u>	<u>BUISNESS LOCATION</u>	<u>BID AMOUNT</u>
<b>Wayne Coleman Construction</b>	<b>Mills, Wyoming</b>	<b>\$90,307.00</b>
Transmission Distribution Services	Glenrock, Wyoming	\$90,777.62
Crown Construction	Mills, Wyoming	\$93,775.00
Knife River	Casper, Wyoming	\$98,214.70
Andreen Hunt Construction	Mills, Wyoming	\$109,350.00
Caspar Building Systems	Casper, Wyoming	\$144,230.60

By State Statute, all in-state bidders receive a five percent (5%) bid preference. The in-state preference does not impact the outcome of the low bidder, as the low bidder was an in-state bidder.

Work is scheduled to be completed by May 15, 2021, and May 29, 2021, for substantial and final completion respectively. The estimate prepared by the City Engineering Department was \$111,900.00.

**Financial Considerations**

The budget available for the project is \$128,155.50 from Capital Reserves.

**Oversight/Project Responsibility**

Ethan Yonker, P.E., Associate Engineer, Public Services

**Attachments**

Resolution

Agreement

STANDARD FORM OF  
AGREEMENT BETWEEN OWNER AND CONTRACTOR

THIS AGREEMENT is made between the City of Casper, Wyoming, 200 North David Street, Casper, Wyoming 82601, hereinafter referred to as the "Owner," and Wayne Coleman Construction, Inc., PO Box 2440, Mills, Wyoming 82644, hereinafter referred to as the "Contractor."

WHEREAS, the City of Casper desires to install sidewalk, pathway and fencing at 1201 Venture Way in Casper; and,

WHEREAS, Wayne Coleman Construction, Inc., is able and willing to provide those services specified as the Horizon Park, Project 20-021.

NOW, THEREFORE, it is hereby agreed as follows:

ARTICLE 1. WORK.

Contractor shall perform all the work required by the Contract Documents for the Horizon Park, Project 20-021.

ARTICLE 2. ENGINEER.

The Project has been designed by the City of Casper Engineering Department who is hereinafter referred to as the "Engineer" and who is to act as an Owner's representative, assume all duties and responsibilities and have the rights and authority assigned to Engineer in the Contract Documents in connection with completion of the Work in accordance with the Contract Documents.

ARTICLE 3. CONTRACT TIME.

Work will be considered substantially complete when all concrete, pavement, irrigation, electrical, mechanical, and landscaping work has been completed. Final completion will be granted upon completion of a walk through with Owner's Representative, completion of punchlist, clean up of work site, and de-mobilization.

- 3.1 The Work will be substantially completed by May 14, 2021, and completed and ready for final payment in accordance with Paragraph 14.13 of the General Conditions by May 28, 2021.
- 3.2 Liquidated Damages. Owner and Contractor recognize that time is of the essence of this Agreement and that Owner will suffer financial loss if the Work is not substantially completed by the time specified in Paragraph 3.1 above, plus any extension thereof allowed in accordance with Article 12 of the General Conditions. They also recognize the delays, expense, and difficulties involved in proving in a legal or arbitration proceeding the actual loss suffered by Owner if the Work is not substantially completed on time. Accordingly,



instead of requiring any such proof, Owner and Contractor agree that as liquidated damages for delay (but not as a penalty) Contractor shall pay Owner Seven Hundred Fifty Dollars (\$750.00) for each day that expires after the time specified in Paragraph 3.1 for substantial completion. After Substantial Completion, if Contractor shall neglect, refuse, or fail to complete the remaining work within the time specified in paragraph 3.1 for completion and readiness for final payment or any proper extension thereof granted by Owner, Contractor shall pay Owner Two Hundred Fifty Dollars (\$250.00) for each day that expires after the time specified in paragraph 3.1 for completion and readiness for final payment. It is further agreed that such liquidated damages are not a penalty, but represent the parties' best estimate of actual damages.

#### ARTICLE 4. CONTRACT PRICE.

Owner shall pay Contractor in current funds for performance of the Work in accordance with the Contract Documents, subject to additions and deductions by Change Order, the contract price of Ninety Thousand Three Hundred Seven Dollars (\$90, 307.00). See Exhibit "A" – Bid Form and Bid Schedule.

#### ARTICLE 5. PAYMENT PROCEDURES.

Contractor shall submit Applications for Payment in accordance with Article 14 of the General Conditions. Applications for Payment will be processed through the Engineer as provided in the General Conditions.

- 5.1 Progress Payments. Owner shall make progress payments on the basis of Contractor's Applications for Payment as recommended by Engineer, on or about the 25th day of each month during construction as provided below. All progress payments will be on the basis of the progress of the Work measured by the Schedule of Values provided for in Paragraph 14.1 of the General Conditions, subject to the cutoff and submittal dates provided in the General Provisions.
  - 5.1.1 Progress payments will be made in an amount equal to ninety-five percent (95%) of the Work completed, and ninety-five percent (95%) of Invoice Cost of materials and equipment not incorporated in the Work but delivered and suitably stored, less in each case the aggregate of payments previously made.
  - 5.1.2 Owner shall withhold five percent (5%) of the work completed as retainage, said retainage to be paid in accordance with the provisions of Paragraph 5.2, Final Payment.
  - 5.1.3 Should amounts owed by the Contractor to the City for any goods, services, licenses, permits or any other item or purpose remain unpaid beyond the City's general credit policy, those amounts may be deducted from the payment being made by the City to the Contractor pursuant to this agreement.

- 5.2 Final Payment. Upon final completion and acceptance of the Work in accordance with Paragraph 14.13 of the General Conditions, Engineer shall recommend payment and present Contractor's Final Application for Payment to the City. Pursuant to Wyoming State Statutes, final payment cannot be made until forty-one (41) days after publication of the first Notice of Completion.

#### ARTICLE 6. WITHHELD FUNDS.

Pursuant to Wyoming Statutes Section 16-6-701 et seq., withheld percentages for Contracts exceeding Twenty-Five Thousand and 00/100 Dollars (\$25,000.00) will be retained in an account in the name of the Contractor (except when specifically waived in writing by Contractor) which has been assigned to the Owner until the Contract is completely, satisfactorily, and finally accepted by the Owner. Unless a depository is designated by the Contractor in a written attachment hereto, the Contractor's signature hereon shall act as authority for the Owner to designate a retainage depository on behalf of the Contractor, for the purposes specified in Wyoming Statutes Section 16-6-704. The Contractor's signature hereon shall act as an assignment of the depository account to the Owner, as provided by Wyoming Statutes Section 16-6-701 et seq., whether the depository is designated by the Contractor or by the Owner.

#### ARTICLE 7. CONTRACTOR'S REPRESENTATIONS.

In order to induce Owner to enter into this Agreement, Contractor makes the following representations:

- 7.1 Contractor has familiarized himself with the nature and extent of the Contract Documents, Work, locality, and with all local conditions and federal, state, and local Laws and Regulations that in any manner may affect cost, progress, or performance of the Work.
- 7.2 Contractor has studied carefully all reports of investigations and test of subsurface and latent physical conditions at the site or otherwise affecting cost, progress, or performance of the work which were relied upon by Engineer in the preparation of the Drawings and Specifications and which have been identified in the Supplementary Conditions.
- 7.3 Contractor has made or caused to be made examinations, investigations, and test and studies as he deems necessary for the performance of the Work at the Contract Price, within the Contract Time, and in accordance with the other terms and conditions of the Contract Documents; and no additional examinations, investigations, tests, reports, or similar data are or will be required by Contractor for such purposes.
- 7.4 Contractor has correlated the results of all such observations, examinations, investigations, tests, reports, and data with the terms and conditions of the Contract Documents.
- 7.5 Contractor has given Engineer written notice of all conflicts, errors, or discrepancies that he has discovered in the Contract Documents and the written resolution thereof by Engineer is acceptable to Contractor.

7.6 Contractor certifies that materials containing asbestos will not be used for this project without prior written approval by the Owner.

#### ARTICLE 8. CONTRACT DOCUMENTS.

The Contract Documents which comprise the entire agreement between Owner and Contractor are attached to this Agreement, made a part hereof and consist of the following:

- 8.1 This Agreement (Pages SFA-1 to SFA-5, inclusive).
- 8.2 Exhibit "A" - Bid Form and Bid Schedule (BF-1 through BF-4 and Bid Schedule).
- 8.3 Joint Account Agreement or Letter of Forfeiture waiving same.
- 8.4 Addenda No.  2 .
- 8.5 Performance and Payment Bonds.
- 8.6 Certificates of Insurance, of Workers' Compensation Coverage, and of Unemployment Insurance Coverage.
- 8.7 Notice of Award.
- 8.8 Notice to Proceed.
- 8.9 Minutes of the Pre-Bid Conference, if any.
- 8.10 General Conditions (Pages 00700-1 to 00700-42, inclusive).
- 8.11 Supplementary Conditions (Pages SSC-1 to SSC-15, inclusive).
- 8.12 Technical Specifications, consisting of six (6) sections.
- 8.13 Special Provisions, consisting of eleven (11) sections
- 8.14 Contract Drawings, consisting of three (3) Sheets
- 8.15 Shop Drawings and other Submittals furnished by Contractor during performance of the Work and accepted by the Owner.
- 8.16 Any modifications, amendments, and supplements, including Change Orders, issued pursuant to Paragraphs 3.4 and 3.5 of the General Conditions, on or after the effective date of this Agreement.

8.17 Notice of Substantial Completion.

ARTICLE 9. GOVERNMENTAL CLAIMS ACT

The Owner does not waive any right or rights it may have pursuant to the Wyoming Governmental Claims Act, Wyoming Statutes Section 1-39-101 et seq. The Owner specifically reserves the right to assert any and all immunities, rights, and defenses it may have pursuant to the Wyoming Governmental Claims Act.

ARTICLE 10. MISCELLANEOUS PROVISIONS.

Terms used in this Agreement, which are defined in the General Conditions, shall have the meanings designated in those conditions.

IN WITNESS WHEREOF, the parties hereto have caused this Agreement to be executed in one (1) original copy on the day and year first above written.

DATED this \_\_\_\_\_ day of \_\_\_\_\_, 2021.

APPROVED AS TO FORM:  
(Horizon Park, Project 20-021)

*Walter Tremel*

ATTEST:

By: \_\_\_\_\_

Title: \_\_\_\_\_

ATTEST:

By: \_\_\_\_\_

Fleur Tremel  
Title: City Clerk

CONTRACTOR:

By: \_\_\_\_\_

Title: \_\_\_\_\_

OWNER:  
CITY OF CASPER, WYOMING  
A Municipal Corporation

By: \_\_\_\_\_

Steven K. Freel  
Title: Mayor

**EXHIBIT "A"**  
**STANDARD**  
**BID FORM**  
(Approved by City Attorney, 1995)

**PROJECT IDENTIFICATION:** City of Casper  
Horizon Park, Project 20-021

**THIS BID SUBMITTED TO:** City of Casper  
200 North David Street  
Casper, Wyoming 82601

1. The undersigned Bidder proposes and agrees, if this Bid is accepted, to enter into an Agreement with the City in the form included in the Bidding Documents and to complete all Work as specified or indicated in the Bidding Documents for the Contract Price by May 15, 2021, and completed and ready for final payment not later than May 29, 2021, in accordance with the Bidding Documents.
2. Bidder accepts all of the terms and conditions of the Advertisement for Bids and Instructions to Bidders, including without limitation those dealing with the disposition of Bid Guaranty. This Bid will remain effective for thirty (30) days after the day of Bid opening. Bidder will sign the Agreement and submit the Bonds and other documents required by the Bidding Documents within thirty (30) days after the date of the City's Notice of Award.
3. Notice that preferences will be granted pursuant to Wyoming Statutes Section 16-6-101, et seq., is hereby acknowledged.
4. In submitting this Bid, Bidder represents, as more fully set forth in the Bidding Documents, that:
  - A. Bidder has examined copies of all the Bidding Documents and of the following addenda (receipt of all which is hereby acknowledged):

Addendum No. <u>1</u>	Dated <u>01/08/2021</u>
Addendum No. <u>2</u>	Dated <u>01/08/2021</u>
  - B. Bidder has examined the site and locality where the work is to be performed, the federal, state, and local Laws and Regulations, and the conditions affecting cost, progress, or performance of the work and has made such independent investigations as Bidder deems necessary;
  - C. This Bid is genuine and not made in the interest of or on behalf of any undisclosed person, firm, corporation, or other business entity. Bidder has not directly or indirectly induced or solicited any other Bidder to submit a false or sham Bid. Bidder

has not solicited or induced any person, firm, or a corporation to refrain from bidding. Bidder has not sought by collusion to obtain for itself any advantage over any other Bidder or against the City.

5. Bidder is bidding all schedules, alternates, if any, and will complete the Work for unit price(s) stated on the attached bid schedule based on materials actually furnished and installed and services actually provided. The Bid is summarized below on the basis of estimated quantities:

TOTAL BASE BID, IN NUMERALS: \$90,307.00

TOTAL BASE BID, IN WORDS: Ninety Thousand, Three Hundred Seven and 00/100 DOLLARS.

6. Bidder agrees that the work for the City will be as provided above.
7. Bidder accepts the provisions of the Bidding Documents as to liquidated damages in the event of failure to complete the work on time, unless otherwise stated as provided below. Bidder agrees that such liquidated damages are not a penalty and that the amount provided is as close an estimate as possible to actual damages. Any exceptions or objections to this provision are stated in writing and attached hereto by Bidder.
8. The following documents are attached to and made a condition of this Bid:
- A. Required Bid Guaranty in the form of a Bid Bond. (Unless otherwise provided by the City.)
  - B. Itemized Bid Schedule.

9. Communications concerning this Bid shall be addressed to:

Address of Bidder: Wayne Coleman Construction, Inc.  
PO Box 2440  
Mills, WY 82644

10. The terms used in this Bid are defined in and have the meanings assigned to them in the General Conditions, except as provided in the Supplementary Conditions and Bidding Documents.

Submitted on January 13, 2021.

Bidder is bidding as a Resident (Insert Resident or Non-Resident)

IF BIDDER IS:

AN INDIVIDUAL

By: \_\_\_\_\_ (seal)  
(Individual's Name)

doing business as: \_\_\_\_\_

Business Address: \_\_\_\_\_  
\_\_\_\_\_  
\_\_\_\_\_

Phone Number: \_\_\_\_\_

A PARTNERSHIP

By: \_\_\_\_\_ (seal)  
(Firm's Name)

\_\_\_\_\_  
(General Partner)

Business Address: \_\_\_\_\_  
\_\_\_\_\_  
\_\_\_\_\_

Phone Number: \_\_\_\_\_



A CORPORATION OR LIMITED LIABILITY COMPANY

By: Wayne Coleman Construction, Inc. (seal)  
(Corporation's or Limited Liability Company's Name)

Wyoming  
(State of Incorporation or Organization)

By:  (seal)  
Seth M. Coleman, President  
(Title)

(Seal)  
Attest: 

Business Address: Wayne Coleman Construction, Inc.  
1898 Melodi Lane  
Casper, WY 82601

Phone Number: 307-265-3158

A JOINT VENTURE

By: \_\_\_\_\_ (seal)  
(Name)

\_\_\_\_\_  
(Address)

By: \_\_\_\_\_ (seal)  
(Name)

\_\_\_\_\_  
(Address)

(Each joint venturer must sign. The manner of signing for each individual, partnership, and corporation that is a party to the joint venture should be in the manner indicated above.)

# Bid Schedule

Exhibit "A"

20-021, HORIZON PARK (#7371315)

Owner: Casper WY, City of

Solicitor: Casper WY, City of

01/13/2021 02:00 PM MST

## Wayne Coleman Construction

Bid Item	Item Description	UofM	Quantity	Unit Price	Extension
					\$90,307.00
1	Mobilization and Bonding	LS	1	\$5,012.00	\$5,012.00
2	F&I 7.5' Curbwalk	LF	435	\$55.00	\$23,925.00
3	F&I 10' Wide Sidewalk	LF	230	\$49.00	\$11,270.00
4	F&I 6' Tall Black Vinyl Coated Chain-Link Fencing	LF	800	\$28.00	\$22,400.00
5	F&I 6' Tall Black Vinyl Coated Chain-Link 4' Wide Gate	EA	2	\$675.00	\$1,350.00
6	F&I 6' Tall Black Vinyl Coated Chain-Link 12' Wide Gate	EA	1	\$1,250.00	\$1,250.00
7	F&I 1' Wide Concrete Retaining Wall	EA	2	\$9,300.00	\$18,600.00
8	F&I Buoy Line	LS	1	\$6,500.00	\$6,500.00
				Base Bid Total:	\$90,307.00

RESOLUTION NO.21-12

A RESOLUTION AUTHORIZING AN AGREEMENT WITH WAYNE COLEMAN CONSTRUCTION, INC., FOR THE HORIZON PARK, PROJECT NO. 20-021.

WHEREAS, the City of Casper desires to enter into a contract for improvements to Horizon Park at 1201 Venture Way, Casper, Wyoming,; and,

WHEREAS, Wayne Coleman Construction, Inc., is able and willing to provide those services specified as the Horizon Park, Project No. 20-021; and,

WHEREAS, it would be in the best interest of the City to expedite changes in the project by allowing the City Manager to sign change orders effecting time extensions of no more than thirty (30) days, dollar amount changes no greater than Nine Thousand and 00/100 Dollars (\$9,000.00) and other project administration related change orders that do not substantially alter the scope of the project.

NOW, THEREFORE, BE IT RESOLVED BY THE GOVERNING BODY OF THE CITY OF CASPER, WYOMING: That the Mayor is hereby authorized and directed to execute, and the City Clerk to attest, an agreement with Wayne Coleman Construction, Inc., for those services, in the amount of Ninety Thousand Three Hundred Seven and 00/100 Dollars (\$90,307.00).

BE IT FURTHER RESOLVED: That the City Manager is hereby authorized to make verified partial payments and contract extensions throughout the project, retaining those amounts prescribed by the agreement, equal to an amount not to exceed Ninety Thousand Three Hundred Seven and 00/100 Dollars (\$90,307.00) and Nine Thousand and 00/100 Dollars (\$9,000.00) for a construction contingency account, for a total price of Ninety-Nine Thousand Three Hundred Seven and 00/100 Dollars (\$99,307.00).

BE IT FURTHER RESOLVED: That the City Manager is hereby authorized to sign change orders effecting time extensions of no more than thirty (30) days, changes in the dollar amount of the above described agreement not greater than the sum of Nine Thousand and 00/100 Dollars (\$9,000.00), and other project administration related change orders that do not substantially alter the scope of the project.

PASSED, APPROVED, AND ADOPTED this \_\_\_\_ day of \_\_\_\_\_, 2021.

APPROVED AS TO FORM:



ATTEST:

CITY OF CASPER, WYOMING  
A Municipal Corporation

\_\_\_\_\_  
Fleur Tremel  
City Clerk

\_\_\_\_\_  
Steven K. Freel  
Mayor

January 20, 2021

MEMO TO: J. Carter Napier City Manager 

FROM: Andrew B. Beamer, P.E., Public Services Director   
Andrew Colling, Engineering Tech

SUBJECT: Authorizing an agreement with Installation & Service Co., Inc., in the amount of \$142,482.50, for the 2<sup>nd</sup> Street Mill & Overlay, Project No. 20-040.

**Meeting Type & Date:**  
Regular Council Meeting  
February 2, 2021

**Action Type**  
Resolution

**Recommendation:**  
That Council, by resolution, authorize an agreement with Installation & Service Co., Inc., in the amount of \$142,482.50, for the 2<sup>nd</sup> Street Mill & Overlay, Project No. 20-040. Furthermore, it is recommended that Council authorize a construction contingency account, in the amount of \$20,000, for a total project amount of \$162,482.50.

**Summary:**  
On Wednesday, January 20, 2021, nine (9) bids were received for the 2<sup>nd</sup> Street Mill & Overlay, Project No. 20-040. The bids received for this work are as follows:

<u>CONTRACTOR</u>	<u>BUSINESS LOCATION</u>	<u>BASE BID</u>
<b>Installation Service Co.</b>	<b>Mills, Wyoming</b>	<b>\$142,482.50</b>
Knife River	Casper, Wyoming	\$147,249.40
Croell, Inc.	Sundance, Wyoming	\$149,537.50
Crown Construction	Mills, Wyoming	\$153,775.00
Andreen Hunt	Mills, Wyoming	\$157,820.00
Wayne Coleman Construction	Mills, Wyoming	\$159,307.00
Ramshorn Construction	Casper, Wyoming	\$165,190.00
Treto Construction	Casper, Wyoming	\$175,750.00
71 Construction	Casper, Wyoming	\$188,634.00

The engineer's estimate prepared by the City Engineering Office was \$143,205.00, with the low bid received at \$142,482.50. Adding a construction contingency amount of \$20,000.00 will bring the total contract amount to \$162,482.50.

Installation & Service Co., Inc.  
2<sup>nd</sup> Street Mill & Overlay  
Project No. 20-040

The project consists of asphalt surface mill and overlay, curb-walk repairs, ADA ramp improvements, and concrete valley gutter replacements along East 2<sup>nd</sup> Street between Landmark Drive and the entrance to Red Lobster. The completion date for the project is June 18, 2021.

As required by State Statute, in-state bidders receive a five percent (5%) bid preference. As all bids were received from in-state Contractors, no bid preference was granted. A notice was published in the local newspaper once a week for two consecutive weeks as required by State Statute and the project was advertised on the City of Casper's website ([www.casperwy.gov](http://www.casperwy.gov)).

**Financial Considerations:**

Funding for this project will be from the One Cent #16 funds allocated to FY21 Miscellaneous Street Improvements.

**Oversight/Project Responsibility:**

Andrew Colling, Engineering Tech

**Attachments:**

Resolution

Agreement

Installation & Service Co., Inc.  
2<sup>nd</sup> Street Mill & Overlay  
Project No. 20-040

STANDARD FORM OF  
AGREEMENT BETWEEN OWNER AND CONTRACTOR

THIS AGREEMENT is made between the City of Casper, 200 North David Street, Casper, Wyoming 82601, hereinafter referred to as the "Owner," and with Installation and Service Co., Inc., PO Box 2938, Mills, Wyoming 82644, hereinafter referred to as the "Contractor."

WHEREAS, the City of Casper desires to mill and overlay a portion of East 2<sup>nd</sup> Street from Landmark Drive to Red Lobster and,

WHEREAS, Installation and Service Co., Inc., is able and willing to provide those services specified as the 2<sup>nd</sup> Street Mill & Overlay Project No. 20-040.

NOW, THEREFORE, it is hereby agreed as follows:

ARTICLE 1. WORK.

Contractor shall perform all the work required by the Contract Documents for the 2<sup>nd</sup> Street Mill & Overlay Project No. 20-040, hereinafter referred to as the "Work."

ARTICLE 2. ENGINEER.

The Project has been designed by the City of Casper, who is hereinafter referred to as the "Engineer" and who is to act as Owner's representative, assume all duties and responsibilities and have the rights and authority assigned to Engineer in the Contract Documents in connection with completion of the Work in accordance with the Contract Documents.

ARTICLE 3. CONTRACT TIME.

- 3.1 The Work will be substantially completed by June 18, 2021, and completed and ready for final payment in accordance with Paragraph 14.13 of the General Conditions by July 2, 2021.
- 3.2 Liquidated Damages. Owner and Contractor recognize that time is of the essence of this Agreement and that Owner will suffer financial loss if the Work is not substantially completed by the time specified in Paragraph 3.1 above, plus any extension thereof allowed in accordance with Article 12 of the General Conditions. They also recognize the delays, expense, and difficulties involved in proving in a legal or arbitration proceeding the actual loss suffered by Owner if the Work is not substantially completed on time. Accordingly, instead of requiring any such proof, Owner and Contractor agree that as liquidated damages for delay (but not as a penalty) Contractor shall pay Owner One Thousand Dollars (\$1,000) for each day that expires after the time specified in Paragraph 3.1 for substantial completion. After Substantial Completion, if Contractor shall neglect, refuse, or fail to complete the remaining work within the time specified in paragraph 3.1 for completion and readiness for final payment or any proper extension thereof granted by Owner, Contractor shall pay Owner Five Hundred Dollars (\$500.00) for each day that expires after the time specified in

paragraph 3.1 for completion and readiness for final payment. It is further agreed that such liquidated damages are not a penalty, but represent the parties' best estimate of actual damages.

#### ARTICLE 4. CONTRACT PRICE.

Owner shall pay Contractor in current funds for performance of the Work in accordance with the Contract Documents, subject to additions and deductions by Change Order, the contract price of One Hundred Forty-Two Thousand Four Hundred Eighty-Two and 50/100 Dollars (\$142,482.50), subject to additions and deductions by Change Order approved by the Owner. The contract fee shall be based on materials actually furnished and installed and services actually provided based on the unit prices contained in the Bid Form and Itemized Bid Schedule, included as Exhibit "A" (pages BF-1 through BF-4, Bid Form and BS-1, Bid Schedule) and by this reference made a part of this Agreement.

#### ARTICLE 5. PAYMENT PROCEDURES.

Contractor shall submit Applications for Payment in accordance with Article 14 of the General Conditions. Applications for Payment will be processed through the Engineer as provided in the General Conditions.

- 5.1 Progress Payments. Contractor's Applications for Payment, as recommended by Engineer, shall be submitted to City Engineering Staff on or before the 25th day of each month during construction, and Owner shall mail progress payments in the following month one day after the second monthly meeting of the Casper City Council. Progress payments shall be structured as provided below. All progress payments will be on the basis of the progress of the Work measured by the Schedule of Values provided for in Paragraph 14.1 of the General Conditions, subject to the cutoff and submittal dates provided in the General Provisions.
  - 5.1.1 Progress payment will be made in an amount equal to ninety-five percent (95%) of the Work completed. Owner shall withhold five percent (5%) of the work completed as retainage, said retainage to be paid in accordance with the provisions of Paragraph 5.3, Final Payment.
  - 5.1.2 Should amounts owed by the Contractor to the City for any goods, services, licenses, permits or any other item or purpose remain unpaid beyond the City's general credit policy, those amounts may be deducted from the payment being made by the City to the Contractor pursuant to this agreement.
- 5.2 OWNER may withhold progress payments if CONTRACTOR fails to submit an updated progress schedule with the application for payment as detailed in Section 01310 Progress Schedules.
- 5.3 Final Payment. Upon final completion and acceptance of the Work in accordance with Paragraph 14.13 of the General Conditions, Engineer shall recommend payment and present



Contractor's Final Application for Payment to the City. Pursuant to Wyoming State Statutes, final payment cannot be made until forty-one (41) days after publication of the first Notice of Completion.

#### ARTICLE 6. WITHHELD FUNDS.

Pursuant to Wyoming Statutes Section 16-6-701 et seq., withheld percentages for Contracts exceeding Fifty Thousand and 00/100 Dollars (\$50,000.00) will be retained in an account in the name of the Contractor (except when specifically waived in writing by Contractor) which has been assigned to the Owner until the Contract is completely, satisfactorily, and finally accepted by the Owner. Unless a depository is designated by the Contractor in a written attachment hereto, the Contractor's signature hereon shall act as authority for the Owner to designate a retainage depository on behalf of the Contractor, for the purposes specified in Wyoming Statutes Section 16-6-704. The Contractor's signature hereon shall act as an assignment of the depository account to the Owner, as provided by Wyoming Statutes Section 16-6-701 et seq., whether the depository is designated by the Contractor or by the Owner.

#### ARTICLE 7. CONTRACTOR'S REPRESENTATIONS.

In order to induce Owner to enter into this Agreement, Contractor makes the following representations:

- 7.1 Contractor has familiarized himself with the nature and extent of the Contract Documents, Work, locality, and with all local conditions and federal, state, and local Laws and Regulations that in any manner may affect cost, progress, or performance of the Work.
- 7.2 Contractor has studied carefully all reports of investigations and tests of subsurface and latent physical conditions at the site or otherwise affecting cost, progress, or performance of the work which were relied upon by Engineer in the preparation of the Drawings and Specifications and which have been identified in the Supplementary Conditions.
- 7.3 Contractor has made or caused to be made examinations, investigations, and tests and studies as he deems necessary for the performance of the Work at the Contract Price, within the Contract Time, and in accordance with the other terms and conditions of the Contract Documents; and no additional examinations, investigations, tests, reports, or similar data are or will be required by Contractor for such purposes.
- 7.4 Contractor has correlated the results of all such observations, examinations, investigations, tests, reports, and data with the terms and conditions of the Contract Documents.
- 7.5 Contractor has given Engineer written notice of all conflicts, errors, or discrepancies that he has discovered in the Contract Documents and the written resolution thereof by Engineer is acceptable to Contractor.

## ARTICLE 8. CONTRACT DOCUMENTS.

The Contract Documents which comprise the entire agreement between Owner and Contractor are attached to this Agreement, made a part hereof and consist of the following:

- 8.1 This Agreement (Pages SFA-1 to SFA-5, inclusive).
- 8.2 Joint Account Agreement or Letter of Forfeiture waiving same.
- 8.3 Exhibit "A" - Bid Form (Pages BF-1 through BF-4) and Bid Schedule (BS-1).
- 8.4 Addenda No. (1).
- 8.5 Performance and Payment Bonds.
- 8.6 Certificates of Insurance, of Workers' Compensation Coverage, and of Unemployment Insurance Coverage.
- 8.7 General Conditions (Pages 00700-1 to 00700-42, inclusive).
- 8.8 Supplementary Conditions (Pages SC-1 to SC-16, inclusive).
- 8.9 General Requirements, consisting of seven (7) sections.
- 8.10 Special Provisions consisting of five (5) sections.
- 8.11 Notice of Award.
- 8.12 Notice to Proceed.
- 8.13 Minutes of the Pre-Bid Conference, if any.
- 8.14 Contract Drawings, with each sheet bearing the following general title:

**2<sup>nd</sup> Street Mill & Overlay Project No. 20-040**
- 8.15 Shop Drawings and other Submittals furnished by Contractor during performance of the Work and accepted by the Owner.
- 8.16 Any modifications, amendments, and supplements, including Change Orders, issued pursuant to Paragraphs 3.04 and 3.05 of the General Conditions, on or after the effective date of this Agreement.
- 8.17 Notice of Substantial Completion.

ARTICLE 9. GOVERNMENTAL CLAIMS ACT

The City does not waive any right or rights it may have pursuant to the Wyoming Governmental Claims Act, Wyoming Statutes Section 1-39-101 et seq. The City specifically reserves the right to assert any and all immunities, rights, and defenses it may have pursuant to the Wyoming Governmental Claims Act.

ARTICLE 10. MISCELLANEOUS PROVISIONS.

Terms used in this Agreement, which are defined in the General Conditions, shall have the meanings designated in those conditions.

IN WITNESS WHEREOF, the parties hereto have caused this Agreement to be executed in one (1) original copy on the day and year below written.

DATED this \_\_\_\_\_ day of \_\_\_\_\_, 2021.

APPROVED AS TO FORM:

*Walter T. ...*

\_\_\_\_\_

CONTRACTOR:

Installation & Service Co., Inc.

ATTEST:

By: \_\_\_\_\_

By: \_\_\_\_\_

Title: \_\_\_\_\_

Title: \_\_\_\_\_

OWNER:

CITY OF CASPER, WYOMING

A Municipal Corporation

ATTEST:

By: \_\_\_\_\_

By: \_\_\_\_\_

Fleur Tremel

Steven K. Freel

Title: City Clerk

Title: Mayor

EXHIBIT "A"  
STANDARD  
BID FORM  
(Approved by City Attorney, 1995)

PROJECT IDENTIFICATION:      City of Casper  
   E. 2<sup>nd</sup> Street Mill & Overlay  
   Project No. 20-040

THIS BID SUBMITTED TO:      City of Casper  
   200 North David Street  
   Casper, Wyoming 82601

1.      The undersigned Bidder proposes and agrees, if this Bid is accepted, to enter into an Agreement with the City in the form included in the Bidding Documents and to complete all Work as specified or indicated in the Bidding Documents for the Contract Price by June 18, 2021, and completed and ready for final payment not later than July 2, 2021 in accordance with the Bidding Documents.
2.      Bidder accepts all of the terms and conditions of the Advertisement for Bids and Instructions to Bidders, including without limitation those dealing with the disposition of Bid Guaranty. This Bid will remain effective for thirty (30) days after the day of Bid opening. Bidder will sign the Agreement and submit the Bonds and other documents required by the Bidding Documents within thirty (30) days after the date of the City's Notice of Award.
3.      Notice that preferences will be granted pursuant to Wyoming Statutes Section 16-6-101, et seq., is hereby acknowledged.
4.      In submitting this Bid, Bidder represents, as more fully set forth in the Bidding Documents, that:
  - A.      Bidder has examined copies of all the Bidding Documents and of the following addenda (receipt of all which is hereby acknowledged):  

Addendum No. <u>  1  </u>	Dated <u>  1-13-2021  </u>
Addendum No. _____	Dated _____
  - B.      Bidder has examined the site and locality where the work is to be performed, the federal, state, and local Laws and Regulations, and the conditions affecting cost, progress, or performance of the work and has made such independent investigations as Bidder deems necessary;
  - C.      This Bid is genuine and not made in the interest of or on behalf of any undisclosed person, firm, corporation, or other business entity. Bidder has not directly or

indirectly induced or solicited any other Bidder to submit a false or sham Bid. Bidder has not solicited or induced any person, firm, or a corporation to refrain from bidding. Bidder has not sought by collusion to obtain for itself any advantage over any other Bidder or against the City.

5. Bidder is bidding all schedules, alternates, if any, and will complete the Work for unit price(s) stated on the attached bid schedule based on materials actually furnished and installed and services actually provided. The Bid is summarized below on the basis of estimated quantities:

TOTAL BASE BID, IN NUMERALS: \$ 142,482.<sup>50</sup>

TOTAL BASE BID, IN WORDS: One hundred forty two thousand, four hundred eighty two <sup>50</sup>/<sub>100</sub> DOLLARS.

6. Bidder agrees that the work for the City will be as provided above.
7. Bidder accepts the provisions of the Bidding Documents as to liquidated damages in the event of failure to complete the work on time, unless otherwise stated as provided below. Bidder agrees that such liquidated damages are not a penalty and that the amount provided is as close an estimate as possible to actual damages. Any exceptions or objections to this provision are stated in writing and attached hereto by Bidder.
8. The following documents are attached to and made a condition of this Bid:
- A. Required Bid Guaranty in the form of a Bid Bond. (Unless otherwise provided by the City.)
  - B. Itemized Bid Schedule.
  - C. State of Wyoming Certificate of Residency Status, in conformance with the Instructions to Bidders.
9. Communications concerning this Bid shall be addressed to:
- Address of Bidder: Installation & Service Co. Inc  
P.O. BOX 39138  
MIAMI, WY 82164
10. The terms used in this Bid are defined in and have the meanings assigned to them in the General Conditions, except as provided in the Supplementary Conditions and Bidding Documents.

Submitted on \_\_\_\_\_, 2021.

Bidder is bidding as a \_\_\_\_\_ (Insert Resident or Non-Resident)

**IF BIDDER IS:**

**AN INDIVIDUAL**

By: \_\_\_\_\_ (seal)  
(Individual's Name)

doing business as: \_\_\_\_\_

Business Address: \_\_\_\_\_  
\_\_\_\_\_  
\_\_\_\_\_

Phone Number: \_\_\_\_\_

**A PARTNERSHIP**

By: \_\_\_\_\_ (seal)  
(Firm's Name)  
\_\_\_\_\_  
(General Partner)

Business Address: \_\_\_\_\_  
\_\_\_\_\_  
\_\_\_\_\_

Phone Number: \_\_\_\_\_

A CORPORATION OR LIMITED LIABILITY COMPANY

By: Installation + Service Co. Inc. (seal)  
(Corporation's or Limited Liability Company's Name)

Wyoming  
(State of Incorporation or Organization)

By: Dennis Spurgeon (seal)  
President  
(Title)

(Seal)  
Attest: [Signature]

Business Address: P.O. BOX 2938  
MILLS, WY 82644

Phone Number: 307.473.9000

A JOINT VENTURE

By: \_\_\_\_\_ (seal)  
(Name)

\_\_\_\_\_  
(Address)

By: \_\_\_\_\_ (seal)  
(Name)

\_\_\_\_\_  
(Address)

(Each joint venturer must sign. The manner of signing for each individual, partnership, and corporation that is a party to the joint venture should be in the manner indicated above.)

**BID SCHEDULE**  
**2nd Street Mill and Overlay**  
**Landmark to Red Lobster**  
**Project No. 20-040**

Bid Date: January 20, 2021

COMPANY NAME: Installation and Service Co., Inc.

ADDRESS: PO Box 2938, Mills, Wyoming 82644

Contractor shall furnish and install items as shown on the Drawings or called for in the Specifications. All costs not included in the schedule that are necessary to provide a complete, functional project as depicted in the Drawings and Specifications are to be considered incidental and merged with costs of other related bid items.

LS = Lump Sum  
 SY = Square Yard

R&R = Remove and Replace  
 FA = Force Account

LF = Linear Feet  
 CY = Cubic Yard

F&I = Furnish and Install  
 EA = Each

ITEM		BASE BID SCHEDULE			
NO.	DESCRIPTION	UNIT	QUANTITY	UNIT COST	TOTAL COST
1	Mobilization	LS	1	\$ 10,000.00	\$ 10,000.00
2	F&I Temporary Traffic Control	LS	1	\$ 8,300.00	\$ 8,300.00
3	Remove Asphalt Surfacing by Cold Milling	SY	5,200	\$ 2.25	\$ 11,700.00
4	F&I 2" Asphalt Overlay	TON	650	\$ 102.00	\$ 66,300.00
5	F&I Asphalt Leveling Course	TON	115	\$ 80.00	\$ 9,200.00
6	R&R Asphalt Section as Patch (4"/8")	SY	156	\$ 55.00	\$ 8,580.00
7	Sub-Excavate & Install Foundation Material	CY	25	\$ 0.10	\$ 2.50
8	Adjust Manhole Top & Install 5' x 5' Concrete Diamond with New Lid	EA	2	\$ 1,100.00	\$ 2,200.00
9	Adjust Valve Box Top & Install 33" x 33" Concrete Diamond	EA	7	\$ 550.00	\$ 3,850.00
10	R&R Concrete Curbwalk with Type II or III ADA Ramp	SF	1,000	\$ 13.25	\$ 13,250.00
11	F&I 2'x4' Truncated Dome Mat Embedded in Concrete Ramp	EA	5	\$ 200.00	\$ 1,000.00
12	R&R Concrete Valley Gutter w/Basecourse	SF	300	\$ 12.00	\$ 3,600.00
13	R&R Concrete Sidewalk w/Basecourse	SF	100	\$ 12.00	\$ 1,200.00
14	Contractor Asphalt Testing	LS	1	\$ 3,300.00	\$ 3,300.00
<b>TOTAL BASE BID (ADDITION OF ITEMS 1 - 14)</b>					<b>\$ 142,482.50</b>



RESOLUTION NO. 21-14

A RESOLUTION AUTHORIZING AN AGREEMENT WITH INSTALLTION & SERVICE CO., INC., FOR THE 2<sup>ND</sup> STREET MILL & OVERLAY PROJECT NO. 20-040.

WHEREAS, the City of Casper desires to perform surface mill and overlay and concrete replacements along East 2<sup>nd</sup> Street between Landmark Drive and the entrance to Red Lobster for the 2<sup>nd</sup> Street Mill & Overlay; and,

WHEREAS, Installation & Service Co., Inc., is able and willing to provide those services specified as the 2<sup>nd</sup> Street Mill & Overlay Project, No. 20-040; and,

WHEREAS, it would be in the best interest of the City to expedite changes in the project by allowing the City Manager to sign change orders effecting time extensions of no more than thirty (30) days, dollar amount changes no greater than Twenty Thousand Dollars (\$20,000.00) and other project administration related change orders that do not substantially alter the scope of the project.

NOW, THEREFORE, BE IT RESOLVED BY THE GOVERNING BODY OF THE CITY OF CASPER, WYOMING: That the Mayor is hereby authorized and directed to execute, and the City Clerk to attest, an agreement with Installation & Service Co., Inc., for those services, in the amount of One Hundred Forty-Two Thousand Four Hundred Eighty-Two and 50/100 Dollars (\$142,482.50).

BE IT FURTHER RESOLVED: That the City Manager is hereby authorized to make verified partial payments and contract extensions throughout the project, retaining those amounts prescribed by the agreement, equal to a total amount not to exceed One Hundred Forty-Two Thousand Four Hundred Eighty-Two and 50/100 Dollars (\$142,482.50) and Twenty Thousand Dollars (\$20,000.00) for a construction contingency account, for a total project amount of One Hundred Sixty-Two Thousand Four Hundred Eighty-Two and 50/100 Dollars (\$162,482.50).

BE IT FURTHER RESOLVED: That the City Manager is hereby authorized to sign change orders effecting time extensions of no more than thirty (30) days, changes in the dollar amount of the above described agreement not greater than the sum of Twenty Thousand Dollars (\$20,000.00) and other project administration related change orders that do not substantially alter the scope of the project.

PASSED, APPROVED, AND ADOPTED this \_\_\_\_ day of \_\_\_\_\_, 2021.

APPROVED AS TO FORM:

*Walter Tremel III*

---

ATTEST:

CITY OF CASPER, WYOMING  
A Municipal Corporation

---

Fleur Tremel  
City Clerk

---

Steven K. Freel  
Mayor

January 20, 2021

MEMO TO: His Honor the Mayor and Members of the City Council  
J. Carter Napier, City Manager *JCN*

FROM: John Henley, City Attorney *JH*

SUBJECT: A Resolution rescinding the City of Casper's participation in the Unified Command to oversee the management of the COVID-19 Pandemic as referenced in Natrona County's Resolution No. 11-20 and the City of Casper's Resolution No. 20-72

**Meeting Type & Date**  
Regular Council Meeting  
February 2, 2021

**Action type**  
Resolution

**Recommendation**  
That Council, by Resolution, consider the rescission of the City of Casper's participation in the Unified Command to oversee management of the COVID-19 Response.

**Summary**  
On April 7, 2020, in response to the COVID-19 Pandemic, Steven K. Freel, Mayor, executed City Resolution No. 20-72/Natrona County Resolution 11-20, titled "Natrona Country, Wyoming Joint Delegation of Authority for COVID-19 Response Resolution"; and Mark Harshman, Deputy Fire Chief, reviewed, signed, and agreed to the authority and responsibilities delegated to him in the Resolution. The Resolution created a Unified Command to oversee the complete management of the COVID-19 Response.

Since that time, circumstances regarding the control and response to the COVID-19 Pandemic have shifted from emergency preparation and response, to the distribution and delivery of vaccines to prevent infections of the COVID-19 virus. The Federal Government and Casper-Natrona County Health Department are primarily handling the delivery and distribution of vaccines.

Find attached a proposed resolution for Council's consideration to authorize the rescission of the City of Casper's participation in the Unified Command.

**Financial Considerations**  
None

**Oversight/Project Responsibility**  
Steven K. Freel, Mayor  
Mark Harshman, Deputy Fire Chief  
City Attorney's Office

**Attachments**

Proposed Resolution

City of Casper Resolution No. 20-72

Natrona County Resolution No. 11-20

**RESOLUTION # 20-72**

**NATRONA COUNTY, WYOMING**

**JOINT DELEGATION OF AUTHORITY FOR COVID-19 RESPONSE  
RESOLUTION**

WHEREAS, the World Health Organization declared the Coronavirus as a worldwide pandemic as of March 11, 2020; and

WHEREAS, the President of the United States declared a national emergency concerning the novel coronavirus disease (COVID-19) on March 13, 2020, specifically stating that in “December 2019 a novel (new) coronavirus known as SARS-CoV-2 (“the virus”) was first detected in Wuhan, Hubei Province, People’s Republic of China, causing outbreaks of the coronavirus disease (COVID-19) that has now spread globally. . . . The spread of COVID-19 within our Nation’s communities threatens to strain our Nation’s healthcare systems. . . . Additional measures . . . are needed to successfully contain and combat the virus in the United States.” The National Emergency Declaration declared that the COVID-19 outbreak in the United States constitutes a national emergency; and

WHEREAS, Mark Gordon, Governor of the State of Wyoming, declared a State of Emergency and Public Health Emergency for the State of Wyoming on March 13, 2020, stating that on March 11, 2020 an individual within the State of Wyoming tested presumptive positive for COVID-19 and the State of Wyoming is experiencing a public health emergency in response to the evolving outbreak of the novel coronavirus as of March 11, 2020. The Declaration of a State of Emergency directs the Director of the Wyoming Department of Health to take all appropriate and necessary actions and in the Director’s judgment any actions necessary to provide aid to those locations where there is a threat or danger to public health, safety and welfare; and

WHEREAS, the Natrona County Board of County Commissioners approved Natrona County Resolution 09-20, *Resolution Recognizing Covid-19 Pandemic*, as of March 17, 2020; and

WHEREAS, Natrona County presently has fourteen (14) confirmed cases of the Coronavirus (COVID-19) with documentation of community spread; and

WHEREAS, the Natrona County Board of County Commissioners have authority and jurisdiction over the unincorporated areas of Natrona County, Wyoming; and

WHEREAS, the City of Casper Fire Department is a fire department of the City of Casper, a Wyoming Municipality; and

WHEREAS, Natrona County oversees the Casper-Natrona County Health Department, which is administered by Anna Kinder, Director of Casper-Natrona County Public Health; and

WHEREAS, the Natrona County Board of County Commissioners desires to grant the power to oversee the complete management of the COVID-19 Response Incident to a Unified Command whose members shall be:

Stacia Hill, Natrona County Emergency Management Coordinator  
Anna Kinder, Director Casper-Natrona County Public Health

**Division Chief Mark Harshman, City of Casper Fire Department**

**NOW THEREFORE, be it resolved by the Natrona County Board of County Commissioners that the Unified Command to oversee the complete management of the COVID-19 Response Incident shall be the following members:**

**Stacia Hill, Natrona County Emergency Management Coordinator  
Anna Kinder, Director Casper-Natrona County Public Health  
Division Chief Mark Harshman, City of Casper Fire Department**

**IT IS FURTHER RESOLVED, that the Unified Commanders (UC), shall give regular reports to the City of Casper through its Mayor, and the Natrona County Board of County Commissioners, and to the other Natrona County Elected Officials; and**

**IT IS FURTHER RESOLVED, that the UC shall adhere to relevant and applicable laws, policies, and professional standards; and**

**IT IS FURTHER RESOLVED, that the UC shall manage this incident under standard protocols and procedures for the incident command system (ICS) and the National Incident Management System (NIMS); and**

**IT IS FURTHER RESOLVED, that the UC shall manage the incident in order of the highest priority to the lowest priority as delineated below:**

- 1. Coordinate all response with the Wyoming Department of Health and with the Natrona County Health Officer.**
- 2. Provide for Emergency Responder, Public Health/Healthcare employee safety.**
- 3. Provide for the protection of public health safety from the COVID-19 disease.**
- 4. Prevent the spread of the COVID-19 disease within the Natrona County, Wyoming population.**
- 5. Provide incident stability.**
- 6. Provide timely, accurate, and relevant information to the public regarding the incident.**
- 7. Provide for minimal disruption of access to critical community services. Access must be consistent with the safety of the public.**
- 8. Coordinate with the Natrona County Emergency Operations Center for resource requests and information sharing.**

**IT IS FURTHER ORDERED that the UC shall comply with the following:**

- 1. That the delegation carries full responsibility of the complete management of the COVID-19 Response Incident within Natrona County, Wyoming, including within the City of Casper, Wyoming.**
- 2. All unified incident commanders shall sign the delegation letter accepting command.**
- 3. That the unified commanders shall organize, manage and direct the assigned resources for complete management of the COVID-19 Response Incident.**
- 4. Assumption of Command began as of March 16, 2020 and shall continue until such time as this resolution is revoked or modified.**
- 5. That the UC shall maintain close coordination with all affected agencies to ensure a safe and efficient transfer of command and continuous, transparent communication.**

DATED THIS \_\_\_\_\_ DAY OF \_\_\_\_\_, 2020.

Robert L. Hendry, Chairwoman  
Natrona County Board of County

Commissioners

Attest: \_\_\_\_\_  
Tracy Good, Natrona County Clerk

DATED THIS 7<sup>th</sup> DAY OF April, 2020.



Steven K. Freel  
Steven K. Freel, Mayor  
City of Casper

Attest: Fleur Tremel  
Fleur Tremel, Casper City Clerk

Reviewed and Agreed:

Stacia Hill  
Stacia Hill  
Natrona County Emergency  
Coordinator

Mark Harshman  
Mark Harshman  
City of Casper Fire  
Deputy Chief

Anna Kinder  
Anna Kinder  
Director, Casper-Natrona  
County Health Department

DATED THIS 7TH DAY OF APRIL, 2020.



Robert L. Hendry  
Robert L. Hendry, Chairman  
Natrona County Board of County

Attest: Tracy Good  
Tracy Good, Natrona County Clerk

My term of office expires  
January 3, 2023

DATED THIS \_\_\_\_\_ DAY OF \_\_\_\_\_, 2020.

\_\_\_\_\_  
Steven K. Freel, Mayor  
City of Casper

Attest: \_\_\_\_\_  
Fleur Tremel, Casper City Clerk

Reviewed and Agreed:

\_\_\_\_\_  
Stacia Hill  
Natrona County Emergency  
Coordinator

\_\_\_\_\_  
Mark Harshman  
City of Casper Fire  
Deputy Chief

\_\_\_\_\_  
Anna Kinder  
Director, Casper-Natrona  
County Health Department



**RESOLUTION # 11-20**

**NATRONA COUNTY, WYOMING**

**JOINT DELEGATION OF AUTHORITY FOR COVID-19 RESPONSE  
RESOLUTION**

WHEREAS, the World Health Organization declared the Coronavirus as a worldwide pandemic as of March 11, 2020; and

WHEREAS, the President of the United States declared a national emergency concerning the novel coronavirus disease (COVID-19) on March 13, 2020, specifically stating that in “December 2019 a novel (new) coronavirus known as SARS-CoV-2 (“the virus”) was first detected in Wuhan, Hubei Province, People’s Republic of China, causing outbreaks of the coronavirus disease (COVID-19) that has now spread globally. . . . The spread of COVID-19 within our Nation’s communities threatens to strain our Nation’s healthcare systems. . . . Additional measures . . . are needed to successfully contain and combat the virus in the United States.” The National Emergency Declaration declared that the COVID-19 outbreak in the United States constitutes a national emergency; and

WHEREAS, Mark Gordon, Governor of the State of Wyoming, declared a State of Emergency and Public Health Emergency for the State of Wyoming on March 13, 2020, stating that on March 11, 2020 an individual within the State of Wyoming tested presumptive positive for COVID-19 and the State of Wyoming is experiencing a public health emergency in response to the evolving outbreak of the novel coronavirus as of March 11, 2020. The Declaration of a State of Emergency directs the Director of the Wyoming Department of Health to take all appropriate and necessary actions and in the Director’s judgment any actions necessary to provide aid to those locations where there is a threat or danger to public health, safety and welfare; and

WHEREAS, the Natrona County Board of County Commissioners approved Natrona County Resolution 09-20, *Resolution Recognizing Covid-19 Pandemic*, as of March 17, 2020; and

WHEREAS, Natrona County presently has fourteen (14) confirmed cases of the Coronavirus (COVID-19) with documentation of community spread; and

WHEREAS, the Natrona County Board of County Commissioners have authority and jurisdiction over the unincorporated areas of Natrona County, Wyoming; and

WHEREAS, the City of Casper Fire Department is a fire department of the City of Casper, a Wyoming Municipality; and

WHEREAS, Natrona County oversees the Casper-Natrona County Health Department, which is administered by Anna Kinder, Director of Casper-Natrona County Public Health; and

WHEREAS, the Natrona County Board of County Commissioners desires to grant the power to oversee the complete management of the COVID-19 Response Incident to a Unified Command whose members shall be:

Stacia Hill, Natrona County Emergency Management Coordinator  
Anna Kinder, Director Casper-Natrona County Public Health

Division Chief Mark Harshman, City of Casper Fire Department

NOW THEREFORE, be it resolved by the Natrona County Board of County Commissioners that the Unified Command to oversee the complete management of the COVID-19 Response Incident shall be the following members:

Stacia Hill, Natrona County Emergency Management Coordinator  
Anna Kinder, Director Casper-Natrona County Public Health  
Division Chief Mark Harshman, City of Casper Fire Department

IT IS FURTHER RESOLVED, that the Unified Commanders (UC), shall give regular reports to the City of Casper through its Mayor, and the Natrona County Board of County Commissioners, and to the other Natrona County Elected Officials; and

IT IS FURTHER RESOLVED, that the UC shall adhere to relevant and applicable laws, policies, and professional standards; and

IT IS FURTHER RESOLVED, that the UC shall manage this incident under standard protocols and procedures for the incident command system (ICS) and the National Incident Management System (NIMS); and

IT IS FURTHER RESOLVED, that the UC shall manage the incident in order of the highest priority to the lowest priority as delineated below:

1. Coordinate all response with the Wyoming Department of Health and with the Natrona County Health Officer.
2. Provide for Emergency Responder, Public Health/Healthcare employee safety.
3. Provide for the protection of public health safety from the COVID-19 disease.
4. Prevent the spread of the COVID-19 disease within the Natrona County, Wyoming population.
5. Provide incident stability.
6. Provide timely, accurate, and relevant information to the public regarding the incident.
7. Provide for minimal disruption of access to critical community services. Access must be consistent with the safety of the public.
8. Coordinate with the Natrona County Emergency Operations Center for resource requests and information sharing.

IT IS FURTHER ORDERED that the UC shall comply with the following:

1. That the delegation carries full responsibility of the complete management of the COVID-19 Response Incident within Natrona County, Wyoming, including within the City of Casper, Wyoming.
2. All unified incident commanders shall sign the delegation letter accepting command.
3. That the unified commanders shall organize, manage and direct the assigned resources for complete management of the COVID-19 Response Incident.
4. Assumption of Command began as of March 16, 2020 and shall continue until such time as this resolution is revoked or modified.
5. That the UC shall maintain close coordination with all affected agencies to ensure a safe and efficient transfer of command and continuous, transparent communication.

DATED THIS 7TH DAY OF APRIL, 2020.

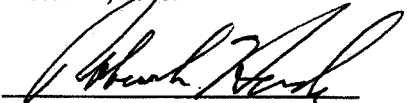

  
Robert L. Hendry, Chairman  
Natrona County Board of County

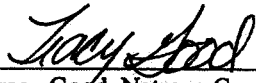
Attest:   
Tracy Good, Natrona County Clerk

**My term of office expires  
January 3, 2023**

DATED THIS \_\_\_\_ DAY OF \_\_\_\_\_, 2020.

\_\_\_\_\_  
Steven K. Freel, Mayor  
City of Casper

Attest: \_\_\_\_\_  
Fleur Tremel, Casper City Clerk

Reviewed and Agreed:

\_\_\_\_\_  
Stacia Hill  
Natrona County Emergency  
Coordinator

\_\_\_\_\_  
Mark Harshman  
City of Casper Fire  
Deputy Chief

\_\_\_\_\_  
Anna Kinder  
Director, Casper-Natrona  
County Health Department

RESOLUTION NO. 21-15

A RESOLUTION TO RESCIND THE JOINT  
DELEGATION OF AUTHORITY FOR COVID-19  
RESPONSE.

WHEREAS, in response to the COVID-19 pandemic, the City of Casper recognized and entered into Natrona County, Wyoming Resolution No. 11-20 (as City of Casper Resolution 20-72) to authorize joint delegation of authority for a COVID-19 response; and,

WHEREAS, Mayor Freel of the City of Casper and Mark Harshman, as City of Casper Deputy Fire Chief, executed on behalf of the City and the City of Casper Fire Department the referenced resolutions; and,

WHEREAS, by the terms of Natrona County Resolution No. 11-20 and City of Casper Resolution No. 20-72, the joint delegation of authority continues until such time the resolutions are revoked; and

WHEREAS, the current circumstances regarding COVID-19 control and response have changed significantly with the emphasis almost exclusively on the delivery, distribution and administration of vaccines to protect against the COVID-19 virus; and,

WHEREAS, the Federal Government and Casper-Natrona County Health Department have the expertise and are primarily handling the delivery and distribution of vaccines to prevent infections of the COVID-19 virus.

NOW, THEREFORE, BE IT RESOLVED BY THE GOVERNING BODY OF THE CITY OF CASPER, WYOMING: That due to the circumstances stated above, the City of Casper hereby rescinds its participation in the unified command as referenced in Resolution No. 11-20 of Natrona County, and Resolution No. 20-72 of the City of Casper; the Mayor of the City of Casper is hereby authorized to execute this Resolution.

PASSED, APPROVED, AND ADOPTED this \_\_\_\_ day of \_\_\_\_\_, 2021.

APPROVED AS TO FORM:

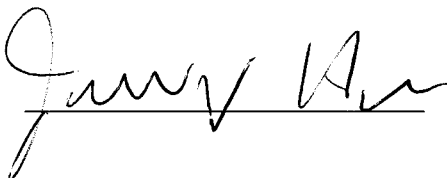

ATTEST:

CITY OF CASPER, WYOMING  
A Municipal Corporation

\_\_\_\_\_  
Fleur Tremel  
City Clerk

\_\_\_\_\_  
Steven K. Freel  
Mayor

January 28, 2021

MEMO TO: J. Carter Napier, City Manager *JCN*  
FROM: Thomas Solberg, Fire Chief  
Cameron Siplon, Deputy Chief  
SUBJECT: Equipment Donation and Release Agreement with Sinclair Casper Refining Co.

**Meeting Type & Date**

Regular Council Meeting  
February 2, 2021

**Action type**

Resolution

**Recommendation**

That Council, by resolution, authorize to accept a donation of used equipment from Sinclair Casper Refining Company and enter into a Release, Acknowledgement and Waiver with the Sinclair Casper Refining Company. The donated items will be located at the Fire Training Facility at 2582 Metro Rd.

**Summary**

The Sinclair Casper Refining Company desires to donate various pieces of used equipment to the Casper Fire Department. These donated items will be additions to an existing prop and will be used by the Casper Fire Department for training purposes. The donation will also include the construction of a small concrete pad to house the equipment.

The Release, Acknowledgement and Waiver has been prepared and executed by Sinclair Casper Refining Company.

A resolution has been prepared for Council's consideration in accepting the donation and entering into the Release, Acknowledgement and Waiver agreement.

**Financial Considerations**

Ongoing Maintenance, this nominal cost can be absorbed in the current CF-EMS training budget.

**Oversight/Project Responsibility**

Cameron Siplon, Deputy Chief Casper Fire-EMS

**Attachments**

Resolution  
Release, Acknowledgment and Waiver  
Exhibit 1

## Release, Acknowledgment and Waiver

In exchange for the donation of the various pieces of used equipment set forth below to be used for training purposes, the City of Casper (the "City"), hereby releases and waives any claims it may have against Sinclair Casper Refining Company, its parent and all other corporate affiliates and all of their officers, directors, owners, employees, and agents for any and all damages or losses of any kind suffered as a result of or in any way related to the use of such donated items.

The City acknowledges that the donated items are donated to the City on an "as is" basis to allow firefighters to train on simulated fire conditions including LPG fires. There is no representation or warranty as to the donated items condition or use.

A description of the donated items and prop placement are attached and labeled as Exhibit 1 "Sinclair Casper Refining Company Donation of Propane Prop" and "Proposed CFD Fire Prop Casper Fire Training Grounds" which consists of two pages and is hereby made part of this Release.

The donated items include:

- 15ft x 20ft Concrete pad and pedestal (detail in attachment)
- 4 in x 2 in Centrifugal Suction Pump with welded mechanical Seal
- 4 in x 22 ft Process Exchanger with attached valves
- ½ in Underground rated Piping buried from proposed Prop to existing Propane manifold (detail in attachment)

The City does not waive any right or rights it may have pursuant to the Wyoming Governmental Claims Act, Wyoming Statutes Section 1-39-101 et seq., and the City specifically reserves the right to assert any and all rights, immunities and defenses it may have pursuant to the Wyoming Governmental Claims Act.

Agreed to this \_\_\_\_ day of \_\_\_\_\_, 2021.

APPROVED AS TO FORM

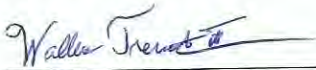
  
\_\_\_\_\_

ATTEST

\_\_\_\_\_  
Fleur Tremel  
City Clerk

CITY OF CASPER, WYOMING  
A Municipal Corporation

\_\_\_\_\_  
Steven K. Freel  
Mayor



WITNESS

SINCLAIR CASPER REFINING COMPANY

By: Bruce Sowers

By: Jim Ruble

Printed Name: Bruce Sowers

Printed Name: Jim Ruble

Title: EHS Manager Sinclair Casper Refinery

Title: Manager- Sinclair Casper Refining Company

State of Wyoming )

County of Natrona )

This Release, Acknowledgement and Waiver was acknowledge before me on the \_\_\_\_\_ day of \_\_\_\_\_, 2021, by Steven K. Freel, as Mayor for the City of Casper, Wyoming.

(Seal)

My Commission Expires:

\_\_\_\_\_  
Notary Public

State of Wyoming )

County of Natrona )

This Release, Acknowledgement and Waiver was acknowledge before me on the 25 day of January, 2021, by James Ruble, as Refinery Manager (title) for Sinclair Refining Company.

(Seal)

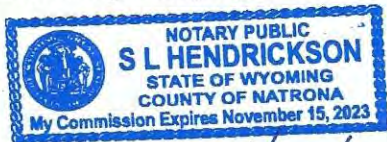

My Commission Expires: 11/15/2023

S L Hendrickson  
Notary Public

# SINCLAIR CASPER REFINING COMPANY DONATION OF PROPANE PROP

## OVERVIEW

Sinclair Casper is pleased to offer an addition to the existing propane prop for the training of Regional and Refinery Firefighters. This will include a concrete pad with pedestals for an exchanger and a pump with valves and an electric motor.

## The Objective

- Provide the ability to train Municipal Firefighters and Industrial Firefighters on LPG fires.
- Get the dilapidated propane tank emergency prop back into usable condition.

## The Opportunity

- Sinclair Casper will donate or pay directly for a contractor time and materials to install the prop.
- Sinclair will trouble shoot existing Propane prop and repair system to become functional.

## Supplied Material

Materials to be supplied by
Concrete pad with Pedestals
One pump with Suction and discharge valves, mechanical Seal, and an electrical motor
One Exchanger with inlet and out let valves

Robert Rattliff Sinclair Casper Refining Company





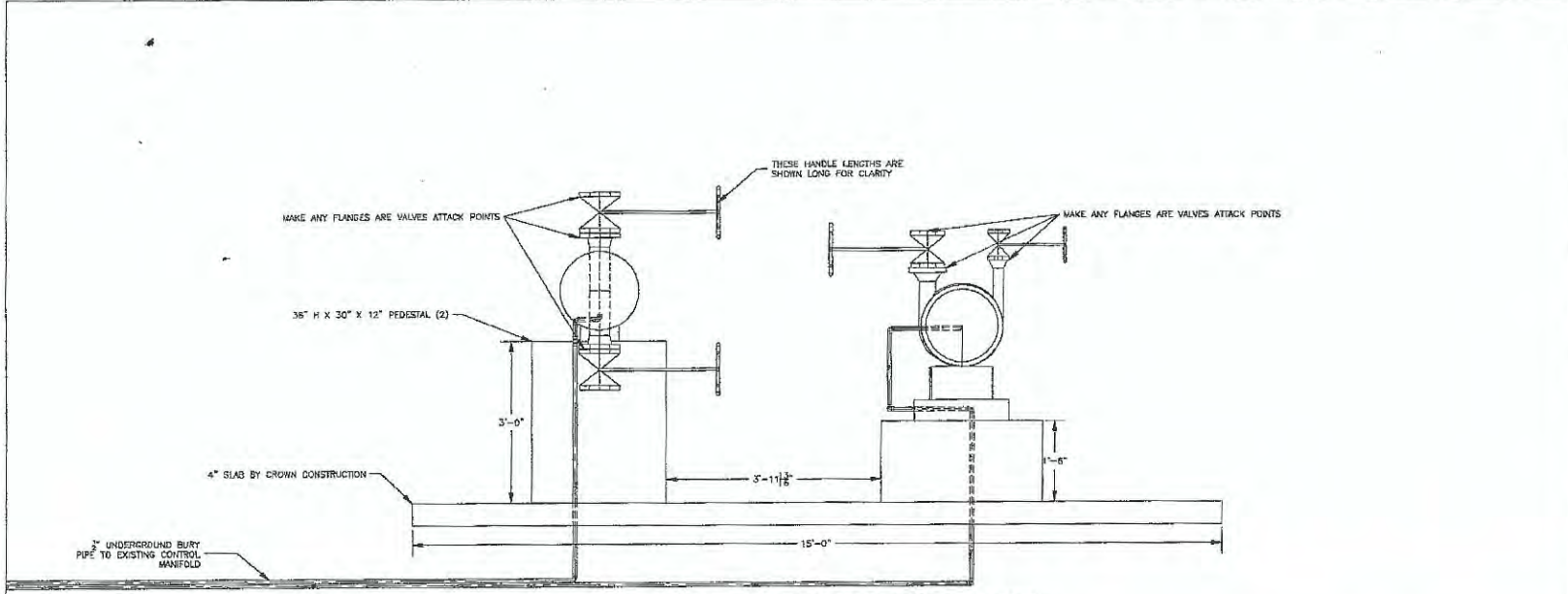

1 PROPANE FIRE / HAZMAT PROP ELEVATION THRU NORTH  
NO SCALE

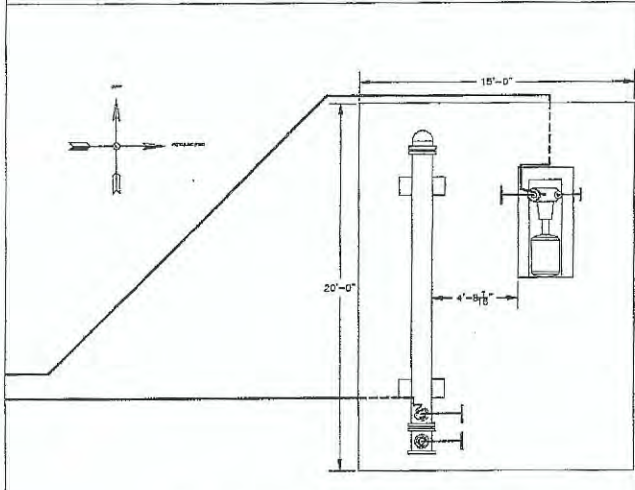

2 PROPANE FIRE / HAZMAT PROP PLAN VIEW  
NO SCALE

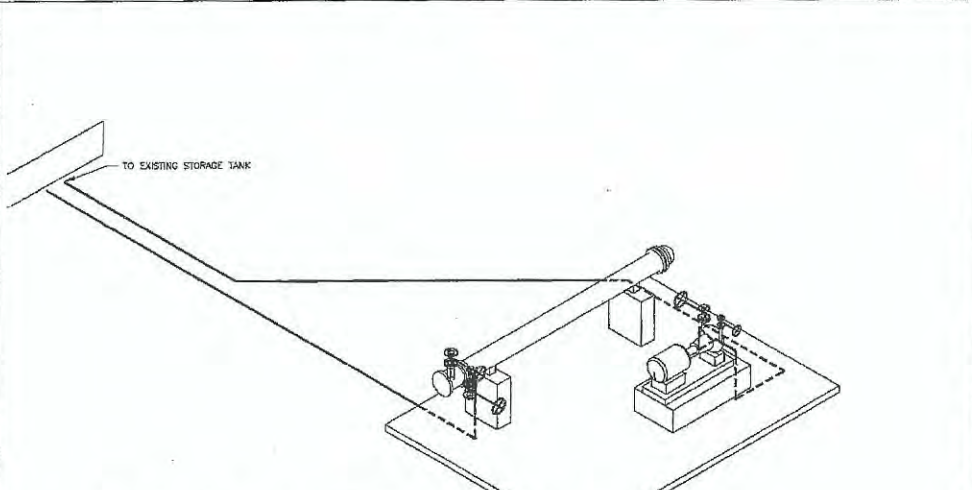

3 PROPANE FIRE / HAZMAT PROP ISO VIEW  
NO SCALE

General Notes		
No.	Revision/Issue	Date
Drawing Name <b>PROPOSED CFD FIRE PROP CASPER FIRE TRAINING GROUNDS</b>		
Project Name and Address Sinclair Piping Projects 2020		
Title <b>EAST OF PROPANE TANK</b>	Designer Drawing Number Author rperkins	

**EXHIBIT**

1  
234

*P. 2 of 2*

RESOLUTION NO. 21-16

A RESOLUTION ACCEPTING A DONATION FROM SINCLAIR CASPER REFINING COMPANY AND AUTHORIZING A RELEASE, ACKNOWLEDGEMENT AND WAIVER BETWEEN THE CITY OF CASPER AND SINCLAIR CASPER REFINING COMPANY.

WHEREAS, Sinclair Casper Refining Company desires to donate various pieces of used equipment to the City of Casper, which are additions to an existing prop and to be used by the Casper Fire Department for training purposes; and,

WHEREAS, the City of Casper desires to accept the donation; and,

WHEREAS, in consideration for the donation, Sinclair Casper Refining Company requests the City of Casper to enter into a Release, Acknowledgement and Waiver attached hereto.

NOW, THEREFORE, BE IT RESOLVED BY THE GOVERNING BODY OF THE CITY OF CASPER, WYOMING: That the Mayor is hereby authorized and directed to execute, and the City Clerk to attest the Release, Acknowledgement and Waiver between Sinclair Casper Refining Company and the City of Casper, Wyoming, and the acceptance of the donation.

PASSED, APPROVED, AND ADOPTED on this \_\_\_\_ day of \_\_\_\_\_, 2021.

APPROVED AS TO FORM:

  
\_\_\_\_\_



ATTEST:

\_\_\_\_\_  
Fleur Tremel  
City Clerk

CITY OF CASPER, WYOMING  
A Municipal Corporation

\_\_\_\_\_  
Steven K. Freel  
Mayor

January 15, 2021

MEMO TO: J. Carter Napier, City Manager   
FROM: Tom Pitlick, Financial Services Director   
SUBJECT: Financial Interest Disclosures for Calendar Year 2021

Meeting Type and Date:  
Regular Council Meeting  
February 2, 2021

Action Type:  
Minute Action

Recommendation:  
That Council, by minute action, acknowledge the receipt of financial disclosure information from City officials with public fund investment responsibility.

Summary:  
According to Wyoming Statute 6-5-118, certain city officials must disclose if they have any financial interests in any financial institution that is also involved with any investment made by the City. A financial interest in any institution dealing with the City's funds can include, but is not limited to: an investment, a checking account, a savings account, and ownership of land or building which the financial institution uses to conduct business. Financial interest disclosures must be made annually in a public meeting and must be made part of the record of proceedings.

The statute requires disclosure of the existence of the financial interest, but it does not require that the specifics of the interest be disclosed. For example: if an individual has a checking account in a bank that also does business with the City, then that individual must indicate that they have an interest in the bank, but they do not need to state that the interest is a checking account, nor do they need to say how much is kept in that checking account.

All Councilmembers, as well as the following members of City Staff, were provided with a Financial Interest Disclosure Form to complete: J. Carter Napier, City Manager; Tom Pitlick, Financial Services Director; Pete Meyers, Assistant Financial Services Director; Evan Condelario, Budget/Accounting Supervisor.

Financial Considerations:  
No financial considerations.

Oversight/Project Responsibility:  
Tom Pitlick, Financial Services Director

Attachments:  
2021 Financial Interest Disclosure Forms

Annual Financial Interest Disclosure Form

Calendar Year 2021

Pursuant to W.S. 6-5-118(a), I am hereby disclosing that, to the best of my knowledge, I have received a pecuniary benefit from, I conduct personal business with, or I have a financial interest in the following depositories or firms that also have involvement with investments of the City of Casper pursuant to W.S. 9-4-831:

- |                                    |                   |                  |
|------------------------------------|-------------------|------------------|
| • Davidson Fixed Income Management | <u>      </u> Yes | <u>  X  </u> No  |
| • First Interstate Bank            | <u>  X  </u> Yes  | <u>      </u> No |
| • Hilltop National Bank            | <u>      </u> Yes | <u>  X  </u> No  |
| • ANB Bank                         | <u>      </u> Yes | <u>  X  </u> No  |
| • Platte Valley Bank               | <u>  X  </u> Yes  | <u>      </u> No |
| • PFM Asset Management, LLC        | <u>      </u> Yes | <u>  X  </u> No  |

I request that submission of this form be made part of the record of proceedings for this meeting.

Name (Print): Steve Cathey

Signed: \_\_\_\_\_



Date: \_\_\_\_\_

1/6/2021

Office Held within the  
Casper City Government:

Councilmember

Annual Financial Interest Disclosure Form

Calendar Year 2021

Pursuant to W.S. 6-5-118(a), I am hereby disclosing that, to the best of my knowledge, I have received a pecuniary benefit from, I conduct personal business with, or I have a financial interest in the following depositories or firms that also have involvement with investments of the City of Casper pursuant to W.S. 9-4-831:

- |                                    |                   |                  |
|------------------------------------|-------------------|------------------|
| • Davidson Fixed Income Management | <u>      </u> Yes | <u>  X  </u> No  |
| • First Interstate Bank            | <u>  X  </u> Yes  | <u>      </u> No |
| • Hilltop National Bank            | <u>  X  </u> Yes  | <u>      </u> No |
| • ANB Bank                         | <u>  X  </u> Yes  | <u>      </u> No |
| • Platte Valley Bank               | <u>  X  </u> Yes  | <u>      </u> No |
| • PFM Asset Management, LLC        | <u>      </u> Yes | <u>  X  </u> No  |

I request that submission of this form be made part of the record of proceedings for this meeting.

Name (Print): Lisa Engebretsen

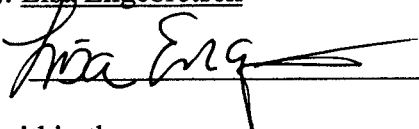
Signed: 

Date: 1/5/21

Office Held within the  
Casper City Government: Councilmember

Annual Financial Interest Disclosure Form

Calendar Year 2021

Pursuant to W.S. 6-5-118(a), I am hereby disclosing that, to the best of my knowledge, I have received a pecuniary benefit from, I conduct personal business with, or I have a financial interest in the following depositories or firms that also have involvement with investments of the City of Casper pursuant to W.S. 9-4-831:

- |                                    |                   |                  |
|------------------------------------|-------------------|------------------|
| • Davidson Fixed Income Management | <u>      </u> Yes | <u>  ✓  </u> No  |
| • First Interstate Bank            | <u>      </u> Yes | <u>  ✓  </u> No  |
| • Hilltop National Bank            | <u>  ✓  </u> Yes  | <u>      </u> No |
| • ANB Bank                         | <u>      </u> Yes | <u>  ✓  </u> No  |
| • Platte Valley Bank               | <u>      </u> Yes | <u>  ✓  </u> No  |
| • PFM Asset Management, LLC        | <u>      </u> Yes | <u>  ✓  </u> No  |

I request that submission of this form be made part of the record of proceedings for this meeting.

Name (Print): Steven K. Freel

Signed: \_\_\_\_\_



Date: \_\_\_\_\_

01/05/21

Office Held within the  
Casper City Government: Mayor

Annual Financial Interest Disclosure Form

Calendar Year 2021

Pursuant to W.S. 6-5-118(a), I am hereby disclosing that, to the best of my knowledge, I have received a pecuniary benefit from, I conduct personal business with, or I have a financial interest in the following depositories or firms that also have involvement with investments of the City of Casper pursuant to W.S. 9-4-831:

- |                                    |                   |                  |
|------------------------------------|-------------------|------------------|
| • Davidson Fixed Income Management | <u>      </u> Yes | <u>  X  </u> No  |
| • First Interstate Bank            | <u>  X  </u> Yes  | <u>      </u> No |
| • Hilltop National Bank            | <u>      </u> Yes | <u>  X  </u> No  |
| • ANB Bank                         | <u>      </u> Yes | <u>  X  </u> No  |
| • Platte Valley Bank               | <u>      </u> Yes | <u>  X  </u> No  |
| • PFM Asset Management, LLC        | <u>      </u> Yes | <u>  X  </u> No  |

I request that submission of this form be made part of the record of proceedings for this meeting.

Name (Print): Kyle Gamroth

Signed: 

Date: 1/05/20

Office Held within the  
Casper City Government: Councilmember

**From:** Shawn Johnson <[shjohnson@cityofcasperwy.com](mailto:shjohnson@cityofcasperwy.com)>

**Date:** January 14, 2021 at 9:03:41 PM MST

**To:** Renee Jordan-Smith <[rjordansmith@casperwy.gov](mailto:rjordansmith@casperwy.gov)>

**Subject: Re: Financial Disclosure Form**

Pursuant to W.S. 6-5-118(a), I am hereby disclosing that, to the best of my knowledge, I have received a pecuniary benefit from, I conduct personal business with, or I have a financial interest in the following depositories or firms that also have involvement with investments of the City of Casper pursuant to W.S. 9-4-831:

- Davidson Fixed Income Management      Yes    X No
- First Interstate Bank                      Yes    X No
- Hilltop National Bank                      Yes    X No
- ANB Bank                                      Yes    X No
- Platte Valley Bank                          Yes    X No
- PFM Asset Management, LLC                Yes    X No

I request that submission of this form be made part of the record of proceedings for this meeting.

Name (Print): Shawn Johnson

Signed: This email will serve as my signature

Office Held within the  
Casper City Government:      Councilmember



Annual Financial Interest Disclosure Form

Calendar Year 2021

Pursuant to W.S. 6-5-118(a), I am hereby disclosing that, to the best of my knowledge, I have received a pecuniary benefit from, I conduct personal business with, or I have a financial interest in the following depositories or firms that also have involvement with investments of the City of Casper pursuant to W.S. 9-4-831:

- |                                    |                   |                  |
|------------------------------------|-------------------|------------------|
| • Davidson Fixed Income Management | <u>      </u> Yes | <u>  X  </u> No  |
| • First Interstate Bank            | <u>      </u> Yes | <u>  X  </u> No  |
| • Hilltop National Bank            | <u>  X  </u> Yes  | <u>      </u> No |
| • ANB Bank                         | <u>      </u> Yes | <u>  X  </u> No  |
| • Platte Valley Bank               | <u>      </u> Yes | <u>  X  </u> No  |
| • PFM Asset Management, LLC        | <u>      </u> Yes | <u>  X  </u> No  |

I request that submission of this form be made part of the record of proceedings for this meeting.

Name (Print): Bruce Knell

Signed: \_\_\_\_\_

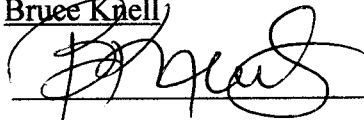

Date: \_\_\_\_\_

1/5/21

Office Held within the  
Casper City Government:

Councilmember

Annual Financial Interest Disclosure Form

Calendar Year 2021

Pursuant to W.S. 6-5-118(a), I am hereby disclosing that, to the best of my knowledge, I have received a pecuniary benefit from, I conduct personal business with, or I have a financial interest in the following depositories or firms that also have involvement with investments of the City of Casper pursuant to W.S. 9-4-831:

- |                                    |           |                 |
|------------------------------------|-----------|-----------------|
| • Davidson Fixed Income Management | _____ Yes | <u>  X  </u> No |
| • First Interstate Bank            | _____ Yes | <u>  X  </u> No |
| • Hilltop National Bank            | _____ Yes | <u>  X  </u> No |
| • ANB Bank                         | _____ Yes | <u>  X  </u> No |
| • Platte Valley Bank               | _____ Yes | <u>  X  </u> No |
| • PFM Asset Management, LLC        | _____ Yes | <u>  X  </u> No |

I request that submission of this form be made part of the record of proceedings for this meeting.

Name (Print): Khrystyn Lutz

Signed: 

Date: 1/5/21

Office Held within the  
Casper City Government: Councilmember

Annual Financial Interest Disclosure Form

Calendar Year 2021

Pursuant to W.S. 6-5-118(a), I am hereby disclosing that, to the best of my knowledge, I have received a pecuniary benefit from, I conduct personal business with, or I have a financial interest in the following depositories or firms that also have involvement with investments of the City of Casper pursuant to W.S. 9-4-831:

- |                                    |   |                             |
|------------------------------------|---|-----------------------------|
| • Davidson Fixed Income Management | <input type="checkbox"/> Yes            | <input type="checkbox"/> No |
| • First Interstate Bank            | <input type="checkbox"/> Yes            | <input type="checkbox"/> No |
| • Hilltop National Bank            | <input checked="" type="checkbox"/> Yes | <input type="checkbox"/> No |
| • ANB Bank                         | <input type="checkbox"/> Yes            | <input type="checkbox"/> No |
| • Platte Valley Bank               | <input type="checkbox"/> Yes            | <input type="checkbox"/> No |
| • PFM Asset Management, LLC        | <input type="checkbox"/> Yes            | <input type="checkbox"/> No |

I request that submission of this form be made part of the record of proceedings for this meeting.

Name (Print): Ray Pacheco

Signed:



Date:

1/5/2021

Office Held within the

Casper City Government: Vice Mayor

Annual Financial Interest Disclosure Form

Calendar Year 2021

Pursuant to W.S. 6-5-118(a), I am hereby disclosing that, to the best of my knowledge, I have received a pecuniary benefit from, I conduct personal business with, or I have a financial interest in the following depositories or firms that also have involvement with investments of the City of Casper pursuant to W.S. 9-4-831:

- |                                    |                   |                  |
|------------------------------------|-------------------|------------------|
| • Davidson Fixed Income Management | <u>      </u> Yes | <u>  X  </u> No  |
| • First Interstate Bank            | <u>  X  </u> Yes  | <u>      </u> No |
| • Hilltop National Bank            | <u>  X  </u> Yes  | <u>      </u> No |
| • ANB Bank                         | <u>      </u> Yes | <u>  X  </u> No  |
| • Platte Valley Bank               | <u>      </u> Yes | <u>  X  </u> No  |
| • PFM Asset Management, LLC        | <u>      </u> Yes | <u>  X  </u> No  |

I request that submission of this form be made part of the record of proceedings for this meeting.

Name (Print): Amber Pollock

Signed: 

Date: 1/5/21

Office Held within the  
Casper City Government: Councilmember

Annual Financial Interest Disclosure Form

Calendar Year 2021

Pursuant to W.S. 6-5-118(a), I am hereby disclosing that, to the best of my knowledge, I have received a pecuniary benefit from, I conduct personal business with, or I have a financial interest in the following depositories or firms that also have involvement with investments of the City of Casper pursuant to W.S. 9-4-831:

- |                                    |                   |                  |
|------------------------------------|-------------------|------------------|
| • Davidson Fixed Income Management | <u>      </u> Yes | <u>  ✓  </u> No  |
| • First Interstate Bank            | <u>      </u> Yes | <u>  ✓  </u> No  |
| • Hilltop National Bank            | <u>  ✓  </u> Yes  | <u>      </u> No |
| • ANB Bank                         | <u>      </u> Yes | <u>  ✓  </u> No  |
| • Platte Valley Bank               | <u>      </u> Yes | <u>  ✓  </u> No  |
| • PFM Asset Management, LLC        | <u>      </u> Yes | <u>  ✓  </u> No  |

I request that submission of this form be made part of the record of proceedings for this meeting.

Name (Print): Evan Condelario

Signed: 

Date: 1/7/2021

Office Held within the  
Casper City Government: Budget/Accounting Supervisor

Annual Financial Interest Disclosure Form

Calendar Year 2021

Pursuant to W.S. 6-5-118(a), I am hereby disclosing that, to the best of my knowledge, I have received a pecuniary benefit from, I conduct personal business with, or I have a financial interest in the following depositories or firms that also have involvement with investments of the City of Casper pursuant to W.S. 9-4-831:

- |                                    |                              |  |
|------------------------------------|------------------------------|--|
| • Davidson Fixed Income Management | <input type="checkbox"/> Yes | <input checked="" type="checkbox"/> No |
| • First Interstate Bank            | <input type="checkbox"/> Yes | <input checked="" type="checkbox"/> No |
| • Hilltop National Bank            | <input type="checkbox"/> Yes | <input checked="" type="checkbox"/> No |
| • ANB Bank                         | <input type="checkbox"/> Yes | <input checked="" type="checkbox"/> No |
| • Platte Valley Bank               | <input type="checkbox"/> Yes | <input checked="" type="checkbox"/> No |
| • PFM Asset Management, LLC        | <input type="checkbox"/> Yes | <input checked="" type="checkbox"/> No |

I request that submission of this form be made part of the record of proceedings for this meeting.

Name (Print): Pete Meyers

Signed: \_\_\_\_\_



Date: \_\_\_\_\_

1/7/21

Office Held within the  
Casper City Government: Assistant Financial Services Director

Annual Financial Interest Disclosure Form

Calendar Year 2021

Pursuant to W.S. 6-5-118(a), I am hereby disclosing that, to the best of my knowledge, I have received a pecuniary benefit from, I conduct personal business with, or I have a financial interest in the following depositories or firms that also have involvement with investments of the City of Casper pursuant to W.S. 9-4-831:

- |                                    |   |                             |
|------------------------------------|---|-----------------------------|
| • Davidson Fixed Income Management | <input type="checkbox"/> Yes            | <input type="checkbox"/> No |
| • First Interstate Bank            | <input checked="" type="checkbox"/> Yes | <input type="checkbox"/> No |
| • Hilltop National Bank            | <input type="checkbox"/> Yes            | <input type="checkbox"/> No |
| • ANB Bank                         | <input type="checkbox"/> Yes            | <input type="checkbox"/> No |
| • Platte Valley Bank               | <input type="checkbox"/> Yes            | <input type="checkbox"/> No |
| • PFM Asset Management, LLC        | <input type="checkbox"/> Yes            | <input type="checkbox"/> No |

I request that submission of this form be made part of the record of proceedings for this meeting.

Name (Print): J. Carter Napier

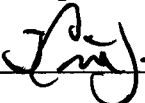
Signed: 

Date: 1/16/21

Office Held within the  
Casper City Government: City Manager

Annual Financial Interest Disclosure Form

Calendar Year 2021

Pursuant to W.S. 6-5-118(a), I am hereby disclosing that, to the best of my knowledge, I have received a pecuniary benefit from, I conduct personal business with, or I have a financial interest in the following depositories or firms that also have involvement with investments of the City of Casper pursuant to W.S. 9-4-831:

- |                                    |                   |                  |
|------------------------------------|-------------------|------------------|
| • Davidson Fixed Income Management | <u>      </u> Yes | <u>  X  </u> No  |
| • First Interstate Bank            | <u>  X  </u> Yes  | <u>      </u> No |
| • Hilltop National Bank            | <u>      </u> Yes | <u>  X  </u> No  |
| • ANB Bank                         | <u>      </u> Yes | <u>  X  </u> No  |
| • Platte Valley Bank               | <u>      </u> Yes | <u>  X  </u> No  |
| • PFM Asset Management, LLC        | <u>      </u> Yes | <u>  X  </u> No  |

I request that submission of this form be made part of the record of proceedings for this meeting.

Name (Print): Tom Pitlick

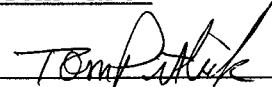
Signed: 

Date: 01/07/2021

Office Held within the  
Casper City Government: Financial Services Director



January 18, 2021

MEMO TO: J. Carter Napier, City Manager 

FROM: Andrew Beamer, P.E., Public Services Director   
Bruce Martin, Public Utilities Manager

SUBJECT: Reappoint Mr. Bruce English to the CPU Advisory Board for a Six-Year Term Ending December 31, 2026.

**Meeting Type & Date**

Regular Council Meeting  
February 2, 2021

**Action Type**

Minute Action

**Recommendation**

That Council, by minute action, reappoint Mr. Bruce English to the Casper Public Utilities Advisory Board for a six-year term beginning January 1, 2021 and ending December 31, 2026.

**Summary**

Mr. English's current six-year CPU Board appointment expired on December 31, 2020. Mr. English is eligible for reappointment, has agreed to be reappointed, and most importantly, brings invaluable expertise and background to the Board.

**Financial Considerations**

There are no financial considerations with this action.

**Oversight/Project Responsibility**

Bruce Martin, Public Utilities Manager

**Attachments**

No Attachments